

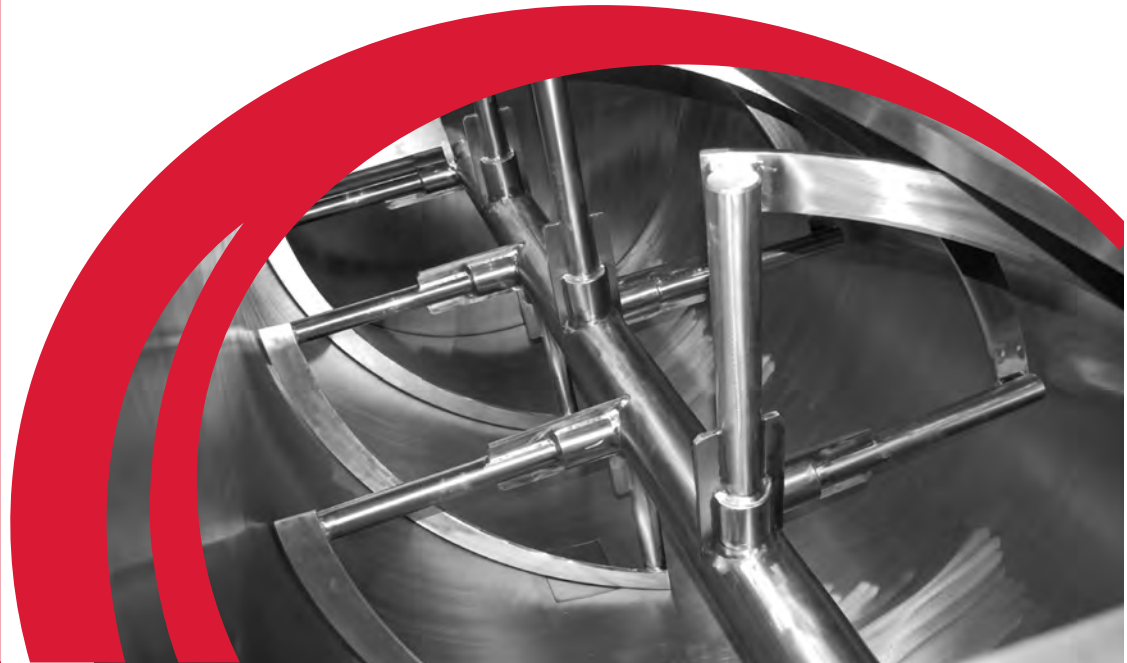

UT

Range

Efficient Ribbon Blenders for Precision



Our U-Trough (UT) mixer is a horizontal mixing machine that is well suited for the efficient blending of free-flowing materials and is considered as the workhorse of the powder mixing industries.

The proven design of Winkworth mixers ensures reliability and longevity. Made in stainless steel and designed to perform for 25 years or more. Features for hygienic mixing, avoidance of cross contamination and high mix quality are all standard paramount in the UT mixer design.

Winkworth 'U' trough mixers incorporate many innovative features aimed at providing improved ergonomics and easier maintenance.

Key Features

- W** 'U' shaped trough for improved access and effective cleaning
- W** Full **stainless steel** construction throughout
- W** Fully welded blade designs
- W** Dust tight lids with quick release closure
- W** Key operated safety interlock systems
- W** All models conform to the "CE Mark" European Directives and the "UKCA" marking requirements
- W** Compact and space saving 'footprint'
- W** Very quiet running, typically around 75dB (a) or less

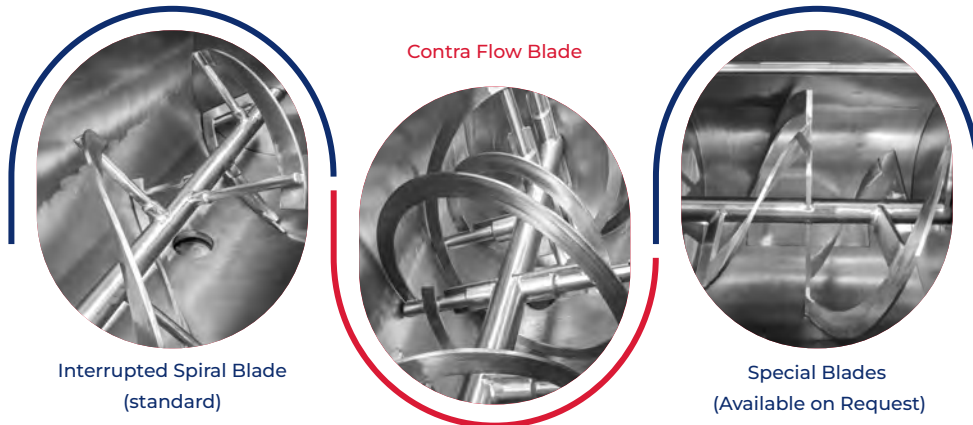

Popular Applications



Features / Specifications

Winkworth tailors each ribbon blender to your unique requirements. The accompanying choice chart, which applies to our entire UT series with working volumes ranging from 25 to 11500 litres, is a guide to help you develop the specification for your machine.

	Standard	Optional
Full stainless steel construction throughout	☑	
Compact drive and control panel solutions	☑	
Dust tight hinged opening lid	☑	
Slide valve outlet	☑	
Interrupted spiral ribbon blade	☑	
Heavy duty models		○
Hardened steels or 316 grade stainless-steel contact parts		○
Heating or cooling jacket		○
Contra-flow spiral or bespoke blade options		○
Vacuum models for drying or de-aerating of the product		○
ATEX certified models for gas / dust zones		○
HMI control panel for recipe control and machine data logging		○
Continuous mixing range		○
Outlets include flush-fit bomb doors, plug valves and butterfly valves. All manual or automated		○
Bespoke lids (Part opening, inlet valve attachments, etc.)		○
High shear refiners		○
Side access hatches		○
Liquid additions / spraying		○

Standard Range

Model	Approx. Capacity (Litres)		Approx. Overall Mixer Dimensions (mm)		Chamber Dimensions (mm)	
	Working	Total	Length (A)	Width (B)	Length (C)	Diameter (D)
UT25	25	42	1000	350	540	270
UT50	50	80	1200	600	663	330
UT100	100	158	1700	700	830	410
UT150	150	218	1650	540	980	460
UT240	240	325	1900	850	1080	540
UT300	300	389	1850	660	1150	570
UT430	430	588	2000	1000	1330	650
UT660	660	866	2400	1300	1500	750
UT1000	1000	1317	2800	1500	1740	870
UT1200	1200	1592	3100	1050	2090	870
UT1500	1500	1979	3365	1180	1990	1000
UT2000	2000	2535	3300	1200	2200	1070
UT3000	3000	4690	4000	1800	2500	1250
UT4000	4000	4930	*	*	2800	1350
UT5000	5000	6456	*	*	2650	1550
UT8500	8500	10850	*	*	3350	1800
UT11500	11500	14150	*	*	2480	2290

All data and dimensions are for illustration purposes only, actual dimensions may vary

* Sizes are dependent on the size of the drives

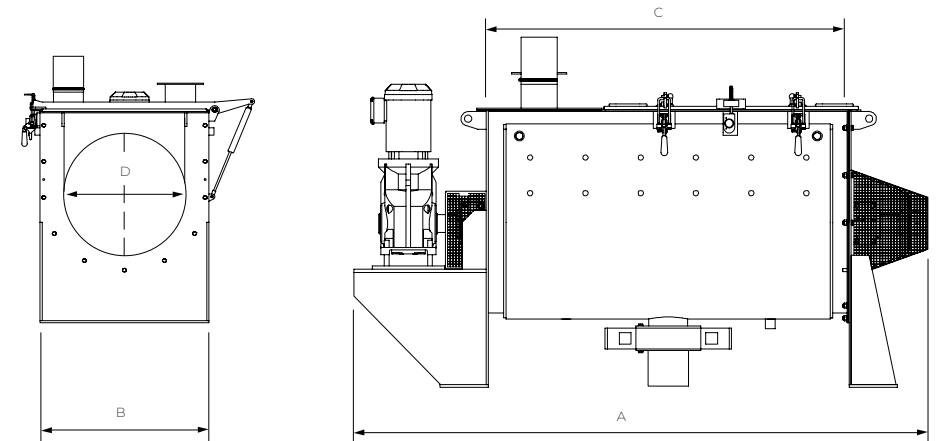

Gallery



Lab UT25



UT with Special Wear Blades



Tilting UT1000



UT1000 Sack Loading Hood



UT100 with Extension Legs



UT240



UT1500 installed on site



UT1500

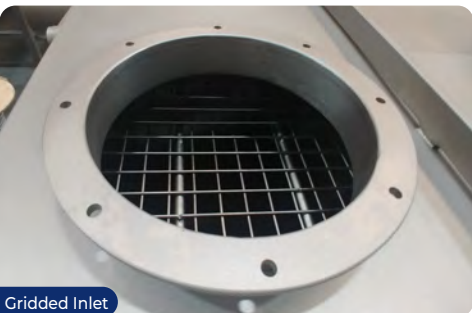

Gridded Inlet



Tilting UT360

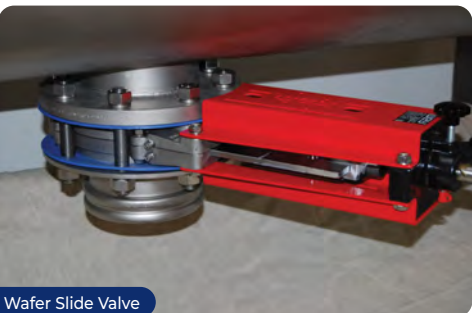

Wafer Slide Valve



UT3000 installed on site



UT660 Vacuum



Spraying System for Liquid Addition



UT5000



UT8500

At Winkworth Machinery, we take pride in our commitment to creating exceptional, bespoke products tailored to your individual preferences. Every piece we craft is as unique as you are, and as such, we would like to make it clear that the images you see in this brochure are for representation purposes only.



Services

- W** Design and Manufacture
- W** Delivery, Installation and Commissioning
- W** Mixing Test Centre and Mixer Hire
- W** Technical Support, Servicing and Repairs

Ready to turn your vision into reality? Contact us today to discuss your bespoke project.

mixer.co.uk | info@mixer.co.uk | +44 (0)1256 305600

Winkworth Machinery Ltd

Mixer House | Stroudley Road | Basingstoke | RG24 8FW | UK