



RWM 40 PET Bottle Press Multi Chamber

Product Specification



Multi-Chamber Waste Baler

RWM 40 PET Bottle Press Multi Chamber

Effortlessly Manage Your PET Bottle Waste

The RWM 40 PET multi-chamber baler simplifies PET recycling with its unique piercing head, which punctures bottles with caps on for denser, more manageable bales. Reducing waste volume cuts handling time, lowers collection costs, and improves site efficiency. This space-saving solution also supports environmental compliance, making PET waste management cleaner and more cost-effective

Basic Specification

- ✓ 12 month warranty
- ✓ Unique bottle piercing head eliminates the need to remove caps from bottle prior to baling
- ✓ Fitted retaining claws to prevent material spring back
- ✓ Compact design – ideal for even the most space-constrained locations
- ✓ Convenient top-loaded feed aperture to prevent material fall out
- ✓ 30 litre residual liquid collection tray with tap connection
- ✓ Additional chambers available
- ✓ Produces bales up to 40kg
- ✓ 2 polyester tape ties per bale
- ✓ 16amp single phase electrics
- ✓ 8 tonne press force
- ✓ Supplied with a free bale trolley
- ✓ Can be sited outdoors

Features

- ✓ Top loading baler
- ✓ PET plastic bottle bale weight of 40 kg
- ✓ Bale ejection trolley included
- ✓ Special piercing compaction head for bottles with lids on



Technical Specifications

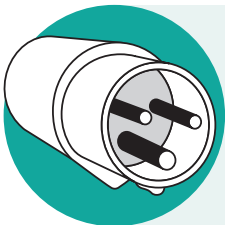
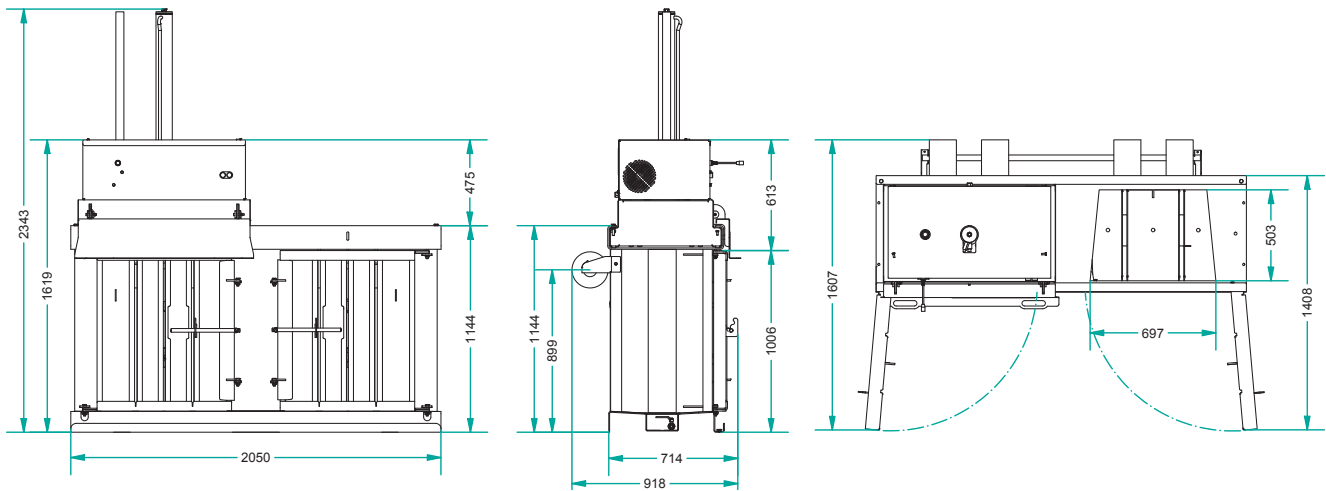

- Operating Voltage: 220–240V
- Frequency: 50Hz
- Connector Plug: 16A, single-phase, standard 3-pin (BS 1363) plug
- MCB (Miniature Circuit Breaker): Type D

Press Force	13 tonnes
Loading Aperture (H x W x D)	700 x 500mm
Bale Weight	Up to 40kg depending on material
Bale Dimensions (H x W x D)	675 x 700 x 500mm
Cycle Time	25 seconds
Noise	68 decibels
Machine Weight	562kg
Power Supply (kW-V-Hz)	16amp single phase 2.2KW 220-240V - 50Hz
Overall Dimensions (H x W x D)	2342 x 2050 x 851mm

Optional Extras

Customise your machine with the optional extras listed below – designed to help you get the most from your equipment, and to suit your specific requirements, operational needs, or site layout.



Galvanised finish
Corrosion-resistant coating for outdoor or harsh, wet environments.



Additional chamber
Add extra chambers for multi-stream waste, reducing loose material stored onsite.



Available in 16amp 3 phase
Supplied in 16amp 3 phase to suit your preferred or existing power supply.