



RWM 40 Baling Press

Product Specification

 Compact Waste Baler

 **Riverside**

wastemachinery.co.uk

RWM 40 Baling Press

Effortlessly Manage Your Recyclable Packaging Waste

A Riverside vertical baler helps businesses cut disposal costs, free up space, and improve efficiency by compacting recyclable materials like cardboard and plastic. Baling reduces handling time, lowers collection expenses, enhances site safety, and can generate revenue through recycling rebates. It also supports environmental compliance, making waste management simpler, cleaner, and more cost-effective.

Basic Specification

- ✓ 12 month warranty
- ✓ Smallest baler in the range; perfect for small volumes of waste
- ✓ Fitted retaining claws to prevent material spring back
- ✓ Suitable for volume reduction of cardboard and plastic
- ✓ Large feed aperture for easy loading
- ✓ Can be sited outside
- ✓ 13amp single phase electrics
- ✓ 2 tonne press force
- ✓ 2 polyester tape ties per bale
- ✓ Supplied with a free bale trolley
- ✓ Bale weights up to 40kg

Features

- ✓ Bale ejection trolley included as standard
- ✓ Suitable for small volumes of waste material
- ✓ Retainers to prevent material spring back



Technical Specifications

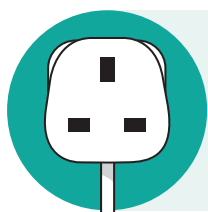
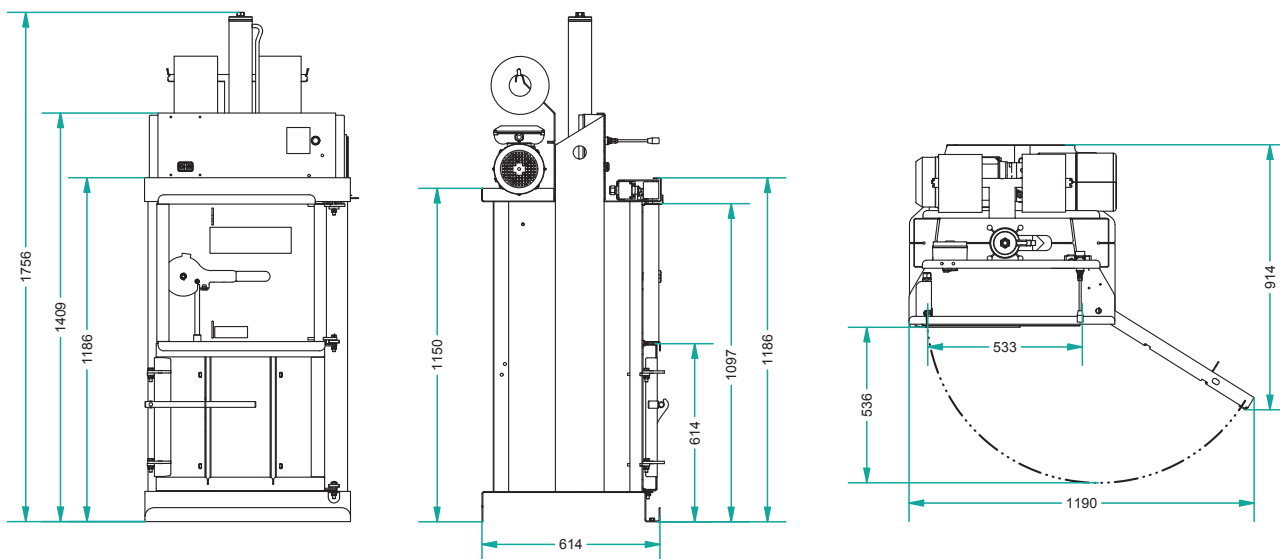

- Operating Voltage: 220–240V
- Frequency: 50Hz
- Connector Plug: 13A, single-phase, standard 3-pin (BS 1363) plug
- MCB (Miniature Circuit Breaker): Type C or above

Press Force	2 tonnes
Loading Aperture (H x W x D)	490 x 522 x 460mm
Bale Weight	Up to 40kg
Bale Dimensions (H x W x D)	600 x 535 x 460mm
Cycle Time	20 seconds
Noise	68 decibels
Machine Weight	187kg
Power Supply (kW-V-Hz)	13amp single phase 1.5KW 220-240V - 50Hz
Overall Dimensions (H x W x D)	1756 x 718 x 644mm
Optional Transportation Height	1400mm

Optional Extras

Customise your machine with the optional extras listed below – designed to help you get the most from your equipment, and to suit your specific requirements, operational needs, or site layout.



Galvanised finish
Corrosion-resistant coating for outdoor or harsh, wet environments.

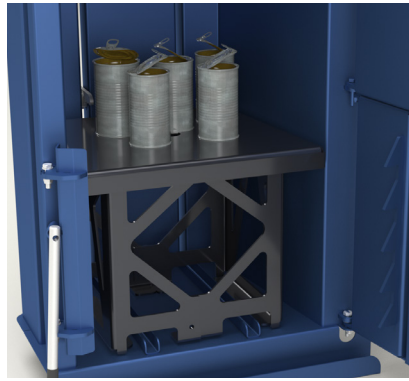

Can crusher insert
Internal insert for crushing cans up to 30 litres and similar rigid containers.



Auto PLC control panel with bale full light
Includes automatic compaction cycle, bale full indicator, E-stop, and key-lock control.



Available in 110 volt
Low-voltage operation, ideal for construction sites and temporary setups.



Available in 16amp 3 phase
Supplied in 16amp 3 phase to suit your preferred or existing power supply.