



RWM 250 Baling Press

Product Specification

 Mid-Range Waste Baler

 **Riverside**

wastemachinery.co.uk

RWM 250 Baling Press

Effortlessly Manage Your Recyclable Packaging Waste

A Riverside vertical baler helps businesses cut disposal costs, free up space, and improve efficiency by compacting recyclable materials like cardboard and plastic. Baling reduces handling time, lowers collection expenses, enhances site safety, and can generate revenue through recycling rebates. It also supports environmental compliance, making waste management simpler, cleaner, and more cost-effective.

Basic Specification

- ✓ 12 month warranty
- ✓ Suitable for volume reduction of cardboard and plastic
- ✓ Large feed aperture for easy loading
- ✓ Can be sited outside
- ✓ 16amp single phase electrics
- ✓ 15 tonne press force
- ✓ 4 polyester tape ties per bale
- ✓ Automatic bale ejection
- ✓ Bale weights up to 250kg

Features

- ✓ Large feed opening
- ✓ Bale ejection
- ✓ Fitted retaining claws to prevent material spring back



Technical Specifications

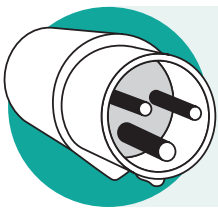
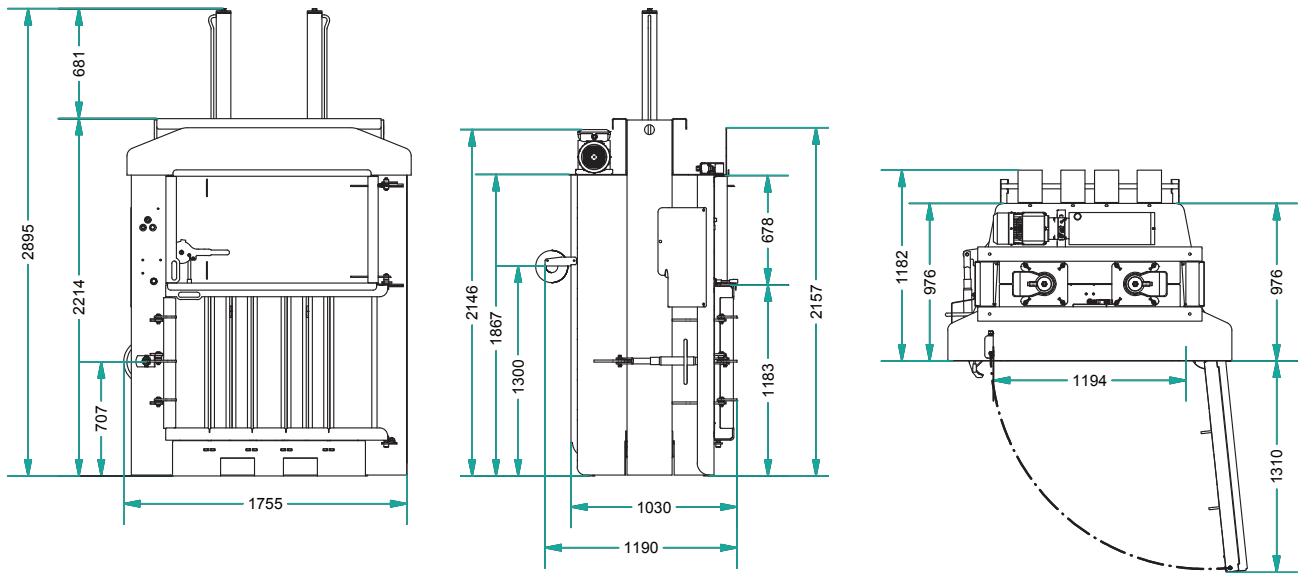

- Operating Voltage: 220–240V
- Frequency: 50Hz
- Connector Plug: 16A, single-phase, standard 3-pin (BS 1363) plug
- MCB (Miniature Circuit Breaker): Type D

Press Force	15 tonnes
Loading Aperture (H x W x D)	678 x 1200 x 800mm
Bale Weight	Up to 250kg
Bale Dimensions (H x W x D)	1000 x 1200 x 800mm
Cycle Time	34 seconds
Noise	68 decibels
Machine Weight	985kg
Power Supply (kW-V-Hz)	16amp single phase 2.2kW 220-240V - 50Hz
Overall Dimensions (H x W x D)	2900 x 1759 x 1185mm
Optional Transportation Height	2250mm

Optional Extras

Customise your machine with the optional extras listed below – designed to help you get the most from your equipment, and to suit your specific requirements, operational needs, or site layout.



Galvanised finish
Corrosion-resistant coating for outdoor or harsh, wet environments.



Sliding top door
Space-saving loading door for use in confined areas or where forklifts/vehicles are operating.



Auto PLC control panel with bale full light
Includes automatic compaction cycle, bale full indicator, E-stop, and key-lock control.



Available in 16amp 3 phase
Supplied in 16amp 3 phase to suit your preferred or existing power supply.