



RWM 200 Multi Chamber baling press

Product Specification

 Multi-Chamber Waste Baler

RWM 200 Multi Baling Press

Effortlessly Manage Multiple Waste Streams

A Riverside multi-chamber baler allows businesses to compact different recyclable materials—such as cardboard, plastic, and paper—in one machine. This reduces handling time, lowers disposal costs, and maximises recycling efficiency. By keeping waste streams separate, it enhances site organisation, improves safety, and supports environmental compliance, all while helping businesses unlock potential recycling rebates.

Basic Specification

- ✓ 12 month warranty
- ✓ Fitted retaining claws to prevent material spring back
- ✓ Additional chambers available
- ✓ Suitable for volume reduction of cardboard and plastic
- ✓ Large feed aperture for easy loading
- ✓ Can be sited outside
- ✓ 16amp single phase electrics
- ✓ 16 tonne press force
- ✓ 4 polyester tape ties per bale
- ✓ Automatic bale ejection
- ✓ Bale weights up to 200kg

Features

- ✓ Top loading baler
- ✓ Full stroke ram cylinder
- ✓ Bale ejection
- ✓ Retainers to prevent material spring back



Technical Specifications

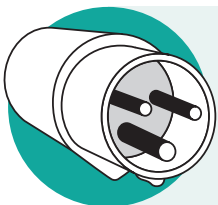
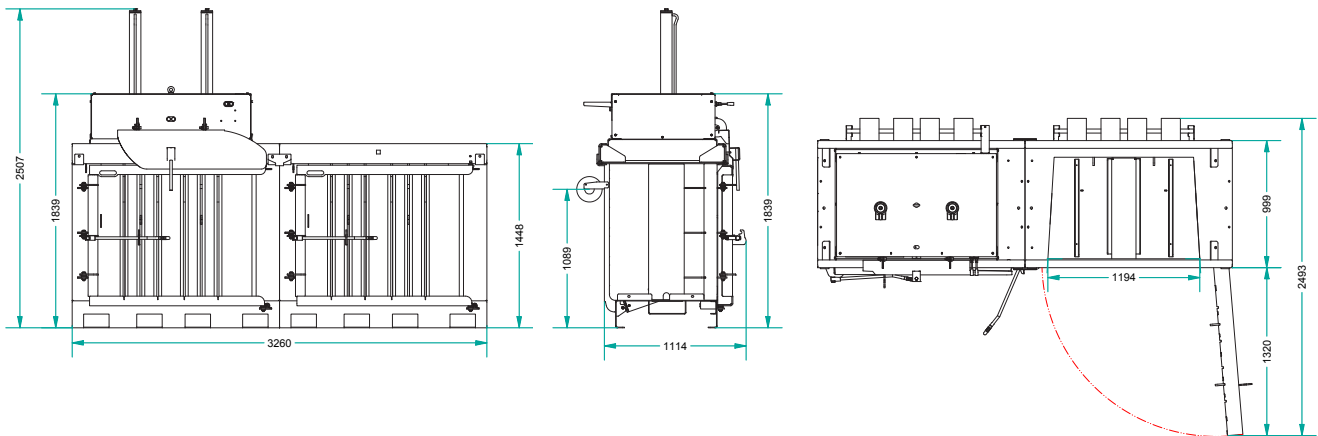

- Operating Voltage: 220–240V
- Frequency: 50Hz
- Connector Plug: 16A, single-phase, standard 3-pin (BS 1363) plug
- MCB (Miniature Circuit Breaker): Type D

Press Force	16 tonnes
Loading Aperture (H x W x D)	1074 x 800mm
Bale Weight	Up to 200kg
Bale Dimensions (H x W x D)	1000 x 1100 x 800mm
Cycle Time	34 seconds
Noise	68 decibels
Machine Weight	1400kg (plus 500Kg per additional Chamber)
Power Supply (kW-V-Hz)	16amp single phase 2.2KW 220-240V - 50Hz
Overall Dimensions (H x W x D)	2506 x 3260 x 1269mm

Optional Extras

Customise your machine with the optional extras listed below – designed to help you get the most from your equipment, and to suit your specific requirements, operational needs, or site layout.



Galvanised finish
Corrosion-resistant coating for outdoor or harsh, wet environments.



Additional chamber
Add extra chambers for multi-stream waste, reducing loose material stored onsite.



Auto PLC control panel with bale full light
Includes automatic compaction cycle, bale full indicator, E-stop, and key-lock control.



Available in 16amp 3 phase
Supplied in 16amp 3 phase to suit your preferred or existing power supply.