



RWM 400 Baling Press

Product Specification

 Mill Size Waste Baler

 **Riverside**

wastemachinery.co.uk

RWM 400 Baling Press

Effortlessly Manage Your Recyclable Packaging Waste

A Riverside vertical baler helps businesses cut disposal costs, free up space, and improve efficiency by compacting recyclable materials like cardboard and plastic. Baling reduces handling time, lowers collection expenses, enhances site safety, and can generate revenue through recycling rebates. It also supports environmental compliance, making waste management simpler, cleaner, and more cost-effective.

Basic Specification

- ✓ 12 month warranty
- ✓ Fitted retaining claws to prevent material spring back
- ✓ Suitable for volume reduction of cardboard and plastic
- ✓ Large feed aperture for easy loading
- ✓ Can be sited outside
- ✓ 16amp 3 phase electrics
- ✓ 25 tonne press force
- ✓ 4 wire ties per bale
- ✓ Automatic bale ejection
- ✓ Bale weights up to 450kg

Features

- ✓ Produces mill size bales
- ✓ Suitable for both wire and tape tying
- ✓ Bale ejection
- ✓ Large feed opening
- ✓ Retainers to prevent material spring back



Technical Specifications

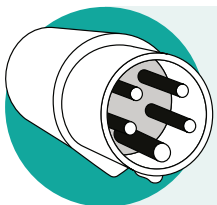
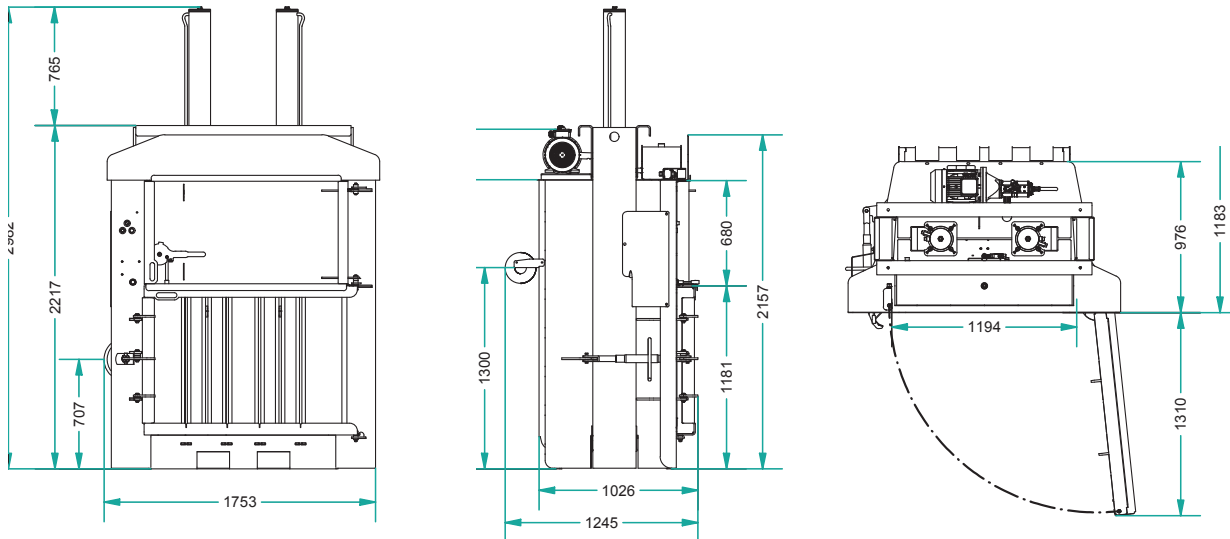

- Operating Voltage: 380–400V
- Frequency: 50Hz
- Connector Plug: 16A, three-phase, 5-pin (3P + N + E) IEC 60309 plug
- MCB (Miniature Circuit Breaker): Type D

Press Force	25 tonnes
Loading Aperture (H x W x D)	680 x 1200 x 800
Bale Weight	Up to 450kg
Bale Dimensions (H x W x D)	1000 x 1200 x 800mm
Cycle Time	40 seconds
Noise	68 decibels
Machine Weight	1300kg
Power Supply (kW-V-Hz)	16amp three phase (E+N) 5.5kW 380-400V – 50Hz
Overall Dimensions (H x W x D)	3000 x 1781 x 1196mm
Optional Transportation Height	2300mm

Optional Extras

Customise your machine with the optional extras listed below – designed to help you get the most from your equipment, and to suit your specific requirements, operational needs, or site layout.



Galvanised finish
Corrosion-resistant coating for outdoor or harsh, wet environments.

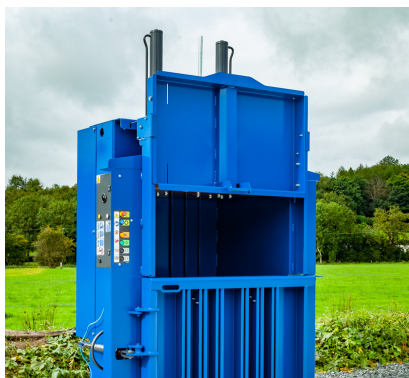

Sliding top door
Space-saving loading door for use in confined areas or where forklifts/vehicles are operating.



Auto PLC control panel with bale full light
Includes automatic compaction cycle, bale full indicator, E-stop, and key-lock control.



Available in 16amp single phase
Ideal for sites without a 3 phase power supply.