



RWM SC3000 Static Compactor

Product Specification

 Compact Waste Baler

 **Riverside**

wastemachinery.co.uk

RWM SC3000

Static Compactor

Effortlessly Manage High-Volume Waste

Riverside static compactors are powerful, space-saving solutions for businesses generating large volumes of waste or recyclables. Designed for maximum efficiency, they significantly reduce waste volume, cutting collection costs and improving site cleanliness. Highly configurable to suit individual needs, these compact yet robust machines offer hassle-free operation, making waste management simpler, cleaner, and more cost-effective.

Basic Specification

- ✓ Open top hopper for easy hand loading or mechanical loading
- ✓ Built in power pack with all controls enclosed
- ✓ PLC controlled system
- ✓ Push blade packing mechanism
- ✓ Galvanised hooks and container ratchets
- ✓ Robust design and heavy duty construction
- ✓ Built to CHEM specification
- ✓ Designed and manufactured to EU machinery directives and certified CE compliant



Benefits

- ✓ Reduced waste collection costs
- ✓ Designed with maximum operator safety in mind
- ✓ Low running costs with Riverside low energy power pack systems
- ✓ Low energy carbon footprint
- ✓ Easy to operate and load
- ✓ Reduced manual handling and risk to staff
- ✓ Streamlined operations
- ✓ Maximum payload on each lift
- ✓ Maximum performance and life long reliability
- ✓ Available in 2 power pack options - 26T and 38T

Optional Fitouts



Open top hopper for bulk loading



Through wall chute loading fit out



GSM modules with performance monitoring and notification system



Bin tipper for 120 to 1100 litre wheeled carts



Off-line power pack cooling systems



Text & email GSM notification system



Enclosed hopper with interlocked access door



Conveyor interfaced hoppers



Guide rail and in-floor plates



Off dock loading



Rear loading bin lifting option



Auto starting systems

RWM SC3000 - with open hopper & bin lifter

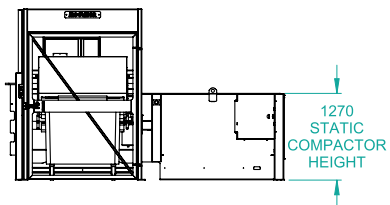
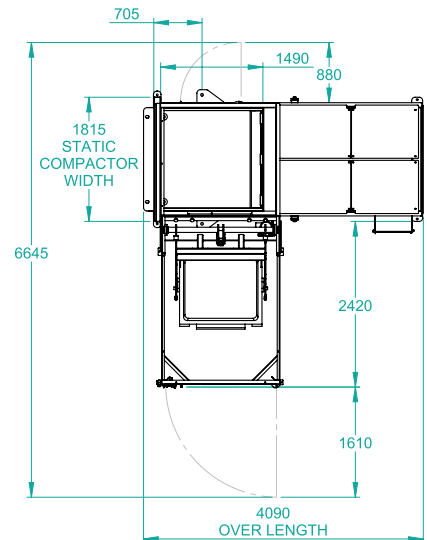
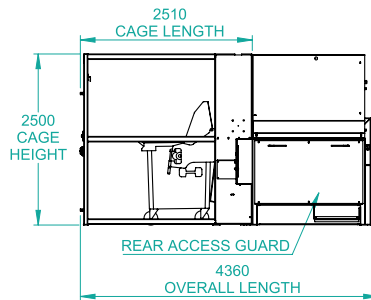
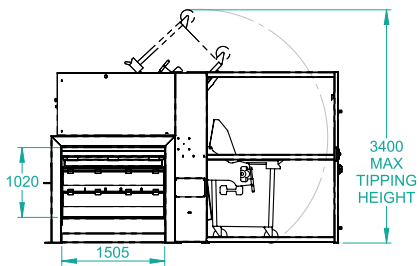
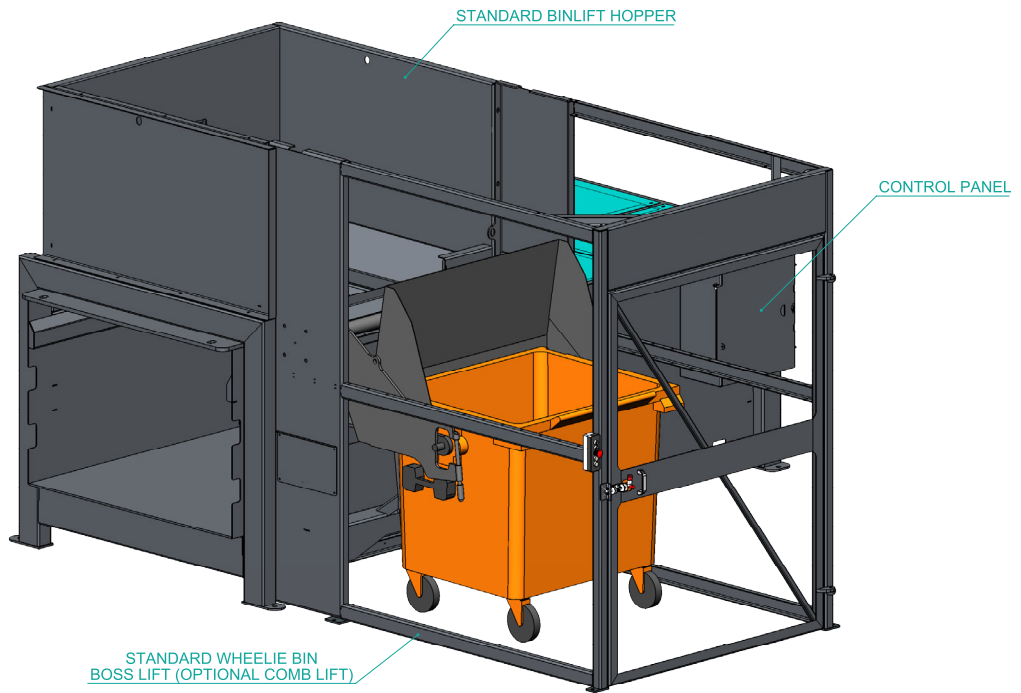

RWM SC3000 - with STD open hopper

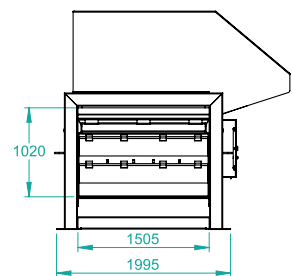
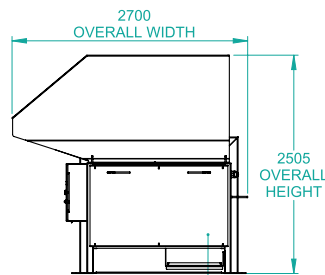
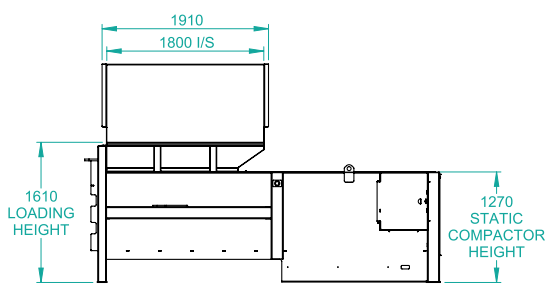
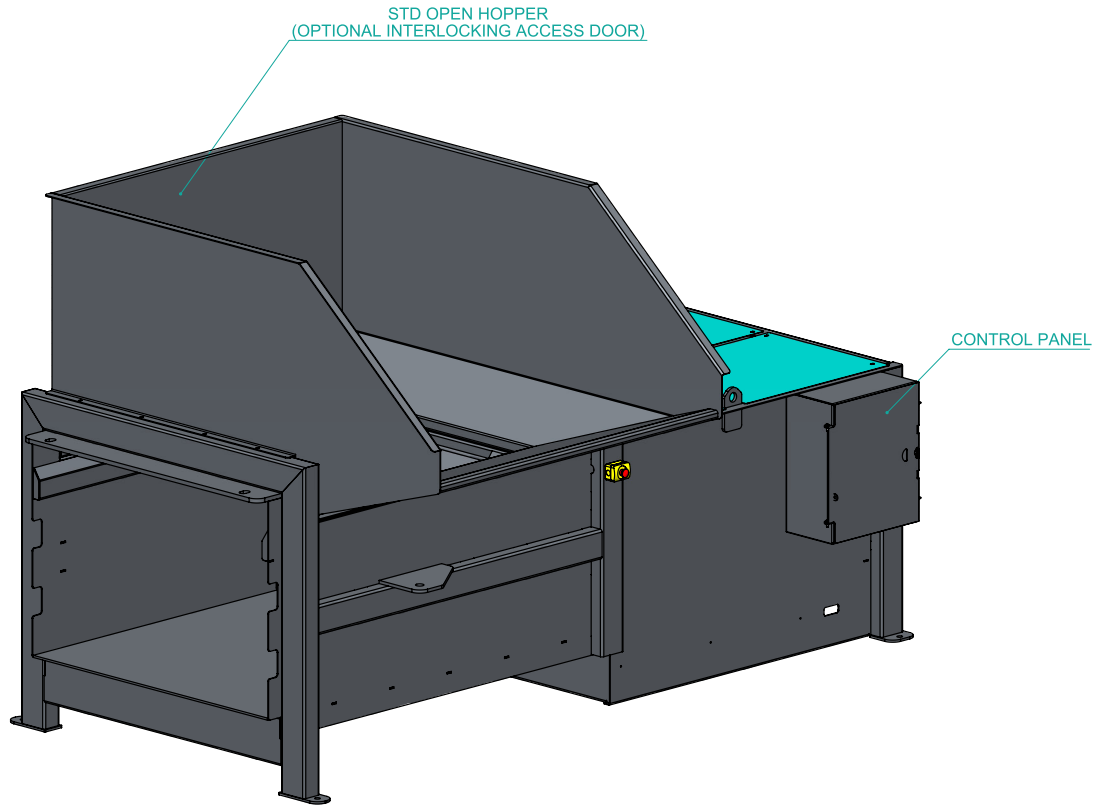

REAR ACCESS GUARD

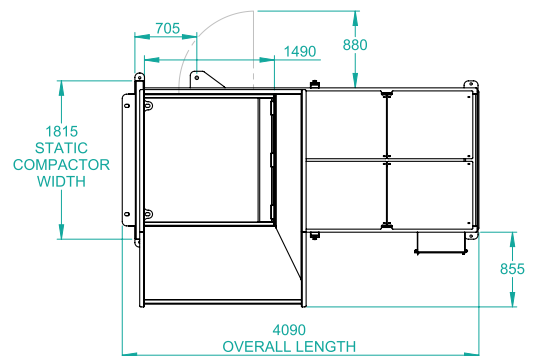

Technical Specifications

Specification	SC3000-26T	SC3000-38T
Compaction force @ 200 bar (tonnes)	26	38
Motor power (kw)	5.5 kW, 16A	5.5 kW, 16A
Power supply	3 PH + E + N, 400V, 50Hz	3 PH + E + N, 400V, 50Hz
Std factory set cycle time (secs)	60	65
Fast cycle options (secs)	46	42
Additional power pack options	11 - 15kw	11 - 18kw
Charge box volume (m ³)	2.15	2.15
Compactor length (Excluding clamps - mm)	4090	4090
Compactor width (Including clamps - mm)	2700	2700
Compactor height (mm)	2505	2505
Loading height (mm)	1610	1610
Chamber width	1505	1505
Chamber length	1500	1500
Chamber height	1020	1020
Chamber weight	3250	3250

Due to company policy of continued product development design and specifications are subject to change without notice.