

Stannah Midilift PL2

Simple, convenient, and versatile:
platform lifts for accessibility in
a limited space



Stannah



Panoramic design, convenient access

The Midilift PL2 is an affordable and compact, platform lift that delivers reliable vertical access for public, residential and commercial environments.

Engineered for effortless integration into both new builds and retrofit projects, it offers specifiers, clients and construction professionals a space-saving solution that supports compliance with the UK's Equality Act and Part M Building Regulations.

With its sleek form, quiet operation, and minimal installation requirements, the PL2 is ideal for projects where aesthetics, performance, and budget must align.

For spaces that demand openness and light, the lift shaft can be glazed on all sides, including the machinery side. This delivers a modern look that keeps the space open and filled with natural light.

Customisable finishes and robust safety features ensure the Midilift PL2 complements contemporary interiors while meeting the highest standards of accessibility and reliability.

CONTENTS

Key benefits & dimensions	4
Features & specifications	5
Finishes & options	6



Key benefits

From private residences and hotels to schools, offices, and shops our platform lifts are designed to fit seamlessly.

- Fast, hassle-free installation – Delivered in ready-made modules with minimal builders' work
- Space-saving design – Compact footprint with minimal structural requirements and shallow 50mm pit
- Quiet operation – Low noise levels (40–55 dB) for minimal disruption
- Reliable performance – Screw and nut drive with soft start/stop functionality
- Built-in safety features – Emergency stop, alarm, battery lowering, overload protection and auto-return to designated floor in case of fire
- Flexible configurations – Multiple platform sizes and access layouts
- Customisable finishes – Wide range of colours, materials, and door options
- Indoor and outdoor suitability – Robust construction for versatile applications

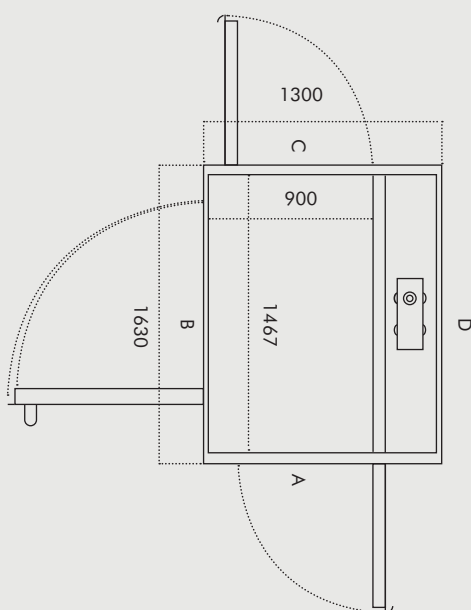

Dimensions

Platform size (w x d)	Footprint size (w x d)
1100 x 1467mm	1500 x 1630mm
1000 x 1467mm	1400 x 1630mm
900 x 1467mm	1300 x 1630mm
900 x 1217mm	1300 x 1380mm

Standard features

- Hold-to-run controls on platform, one-touch on landings
- Emergency stop button, alarm and communication device
- Battery emergency lowering. Automatic return to floor in the event of a fire
- Safety edges for the top of the platform and floor
- Overload protection
- Lift structure with steel panel infills (optional glass infills)
- Full height landing door (half height gate option)

Technical specification

Standard load	400 kg (500 kg on request)
Speed (m/s)	0.15 m/s
Maximum travel	12 meters, up to 3m for half height gate
Minimum travel	900 mm
Maximum stops	Up to 5
Pit depth	50mm or ramp option
Minimum headroom	2250 mm
Application	Indoor or outdoor
Drive type	Screw and nut
Control type	Constant pressure
Power supply	400kg - 240V 1Phase, 50Hz, 20A 500kg - 400V 3Phase, 50Hz, 20A
Entrance configurations	Single entry, open-through, adjacent access (on sides abc)
Landing and lift car doors	Aluminium (standard) with steel option for fire-rated doors (EI60)
Shaft panels	Steel or laminated safety glass
Noise	Between 40–55 dB
Warranty	24-month warranty and 4 service visits per year

Robust safety and trusted compliance

At Stannah, safety is paramount. The Midilift PL2 is built to meet the highest industry standards, ensuring peace of mind. Every lift is designed to comply with:

- EN81-41:2010 – Vertical lifting platforms for persons with impaired mobility
- UKCA Marking – Fully compliant with the Supply of Machinery (Safety) Regulations 2008
- 2006/42/EC Machinery Directive

Whilst also helping to meet with the Equality Act, Part M Building Regulations (England and Wales), and Section 4.2 of the Building Regulations Technical Handbook (Scotland).

Lift finishes & options

Match the look to your project

Choose from a variety of finishes, colours, and configurations to ensure the lift complements your design vision.

Structure and doors



White
(Close to RAL 9016)



Black
(Close to RAL 9011)

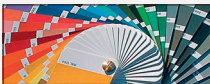

Any RAL colour
(Additional charge)

Platform floor options



Black pitch
G804

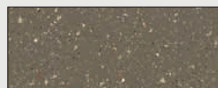

Original umber
G804

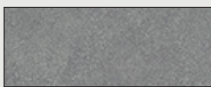

Stone grey speckled
G804



Star snow
G804

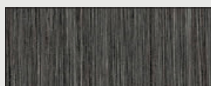

Black seagrass
G804

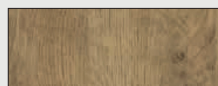

Natural oak
G804

Please note: We are continually developing and improving our range of products and finishes and therefore reserve the right to alter or amend the specification without prior notice.



Expert support you can count on

Stannah brings trusted advice to your project. From exploring the options and providing a free quotation, to detailed builder's drawings, expert installation and ongoing maintenance. We're here every step of the way.

With more than 150 years of lift experience, and millions of customers served, we understand the value of personalised service. Every customer, and every building, is unique – a truth we consider in every lift we build.

Whether you're a homeowner or a professional, you'll enjoy a tailored service, including technical advice, a dedicated project engineer and maintenance support post installation.

With Stannah, you get:

- ✓ A company you can rely on
- ✓ Costs that make sense
- ✓ Superior service and ongoing care
- ✓ Quality guaranteed



Always true to our word

Six steps to your ideal lift



You make contact

You can contact us via email or phone to get started on your Stannah journey, sending any photos, project details, building drawings or required specification you may have.



We'll provide a free no-obligation quote

Based on your information we can either supply a free no-obligation quote or if needed we'll get in touch to visit your home or commercial location to discuss your options.



Confirm your interest

Once you've decided to proceed, and you're happy with the quote, just give us a quick call and we'll begin finalising contracts and getting to work on your builder's work drawings and requirements to enable you to get the site ready for lift installation.



Getting site ready

Working to our product delivery timescales and any project deadlines, as the project progresses your dedicated project engineer will visit. They'll run through the lift specification with you and complete any dimensional checks we need before installation.



Installation begins

Two of our NVQ-qualified installers will fit your lift quickly and safely, working to the highest standards. Once ready for the final stages of lift install we'll provide a detailed handover to ensure you are confident using your lift.



Ongoing support from a leading service company

Every one of our latest Midilift PL2 products comes with the added reassurance of ongoing servicing through one of our 11 service branches. Our branch network takes care of all makes and models of lifts and our exemplary service levels, breadth of coverage, and 100,000-strong service portfolio set us apart from the competition.



A family business
since 1867

Meet the family



**Stairlifts &
homelifts**



**Platform
lifts**



**Passenger
lifts**



**Goods &
service lifts**



**Escalators &
moving walkways**



**Refurbishment,
service & repair**

Stannah Lifts

Stannah Lifts
Watt Close, East Portway, Andover SP10 3SD
contact@stannah.co.uk
Telephone: 01264 351922

www.stannahlifts.co.uk

Stannah