



Control.
Visibility.
Intelligence.

irus

SpaceHeat

Central control for room heating
Building energy management system



Take control of **Energy** for heating and environmental conditions within individual rooms with a system **designed specifically** for **multi-occupancy accommodation**.



**Control.
Visibility.
Intelligence.**

The provision of multi-occupancy presents many challenges. Safety, comfort and affordability being top of the list.

Since 1997 we have been developing products and specifically for this sector.

Our core focus is to deliver systems that help our customers provide **comfortable, safe, and compliant** accommodation while maximising operational efficiency.

Prefect Irus is a centrally controlled building energy management ecosystem, initially designed to monitor and manage energy consumption at point-of-use. Over time, hardware and software development has expanded the capabilities of the system.

Data collected from each room is analysed to provide recommendations for additional efficiencies, and the ability to pinpoint potential issues. Interventions can then be made to avoid escalating problems. The data helps inform strategic energy management decisions.

Building operators gain **control, visibility and intelligence** remotely via a secure internet portal.



Room heating control

Occupancy

Humidity

Light

Sound pressure

CO₂



irus **SpaceHeat**

Central control for room heating
Building energy management system



Internet based portal

The user friendly, intuitive web based portal provides access to the system and control from anywhere with internet connectivity. Managers have complete control of individual environments without ever having to set foot in a room.

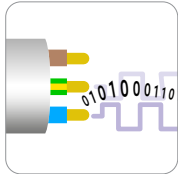

Mains Borne Signalling (MBS)

The system uses the existing electrical circuits within the building to transmit data via the Earth and Neutral wiring. MBS makes installation quick, and negates the need for additional data cabling or extensive interference with the building's infrastructure.



Window-open technology

If windows or doors are opened, the ControlSensor will detect a sudden drop in temperature and Iirus will reduce heat input. This prevents thermostats from being set to maximum and left on while heat escapes.



EnergyLock

Our patented key enables 'no controls' electric panel heaters and fluid-filled radiators to be installed that comply with LOT20 legislation.



Student welfare

It's not all about energy savings with Prefect Iirus - light, humidity, CO₂* and sound pressure levels are also monitored. This means issues such as damp, noise or air quality are reported before they become a major problem. Alerts are sent by text or email. (*Optional)



Maintenance

Maintenance teams are sent email and/or SMS messages so they can pinpoint works that need to be carried out. Iirus identifies the fault, sends the message, records and reports data to generate a minute by minute log of the issues found, and actions taken.

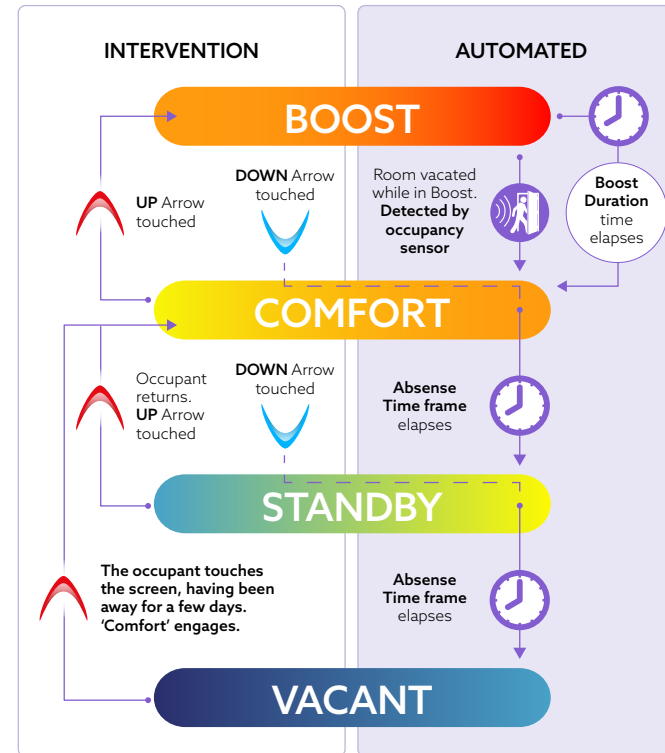

The 4-State Stages

Temperature and time settings are programmed on the portal for four states - **Boost**, **Comfort**, **Standby** and **Vacant**. Room occupants have control over their environment but only within these pre-set parameters. **Comfort** maintains a comfortable temperature. For more warmth the 'UP' arrow is touched to enter **Boost**. When the pre-set time elapses **Comfort** re-engages.

This diagram shows how Iirus is always striving to save energy.

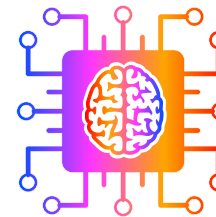

Machine learning and AI

Remote control is a given with Iirus, but our new generation makes Dynamic Remote Control possible. Energy input is determined by occupant behaviour and actual usage of the system as opposed to a prescriptive profile approach.

AI is employed to interrogate Iirus' vast data bank to present insight that answers very specific questions from users. These could relate to issues or characteristics that affect the property.



The diagram illustrates a typical layout for the Irus hardware. Data is transferred between the room controller and Secondary Interface Unit via the Earth and Neutral wiring of the existing electrical circuits. The SIFU boosts the signal and sends the data along Cat. 5 cable to the Main Interface Unit. The MIFU processes the data, returns instructions to the controllers, valves and any connected devices. Information from the MIFU is presented to the Irus Portal.

Installation and Commissioning

Installation is quick and efficient. When all hardware fitting is complete, one of our Project Managers will install the MIFU, test, and commission the system. Time and temperature parameters, or profiles, are set and the project is complete.

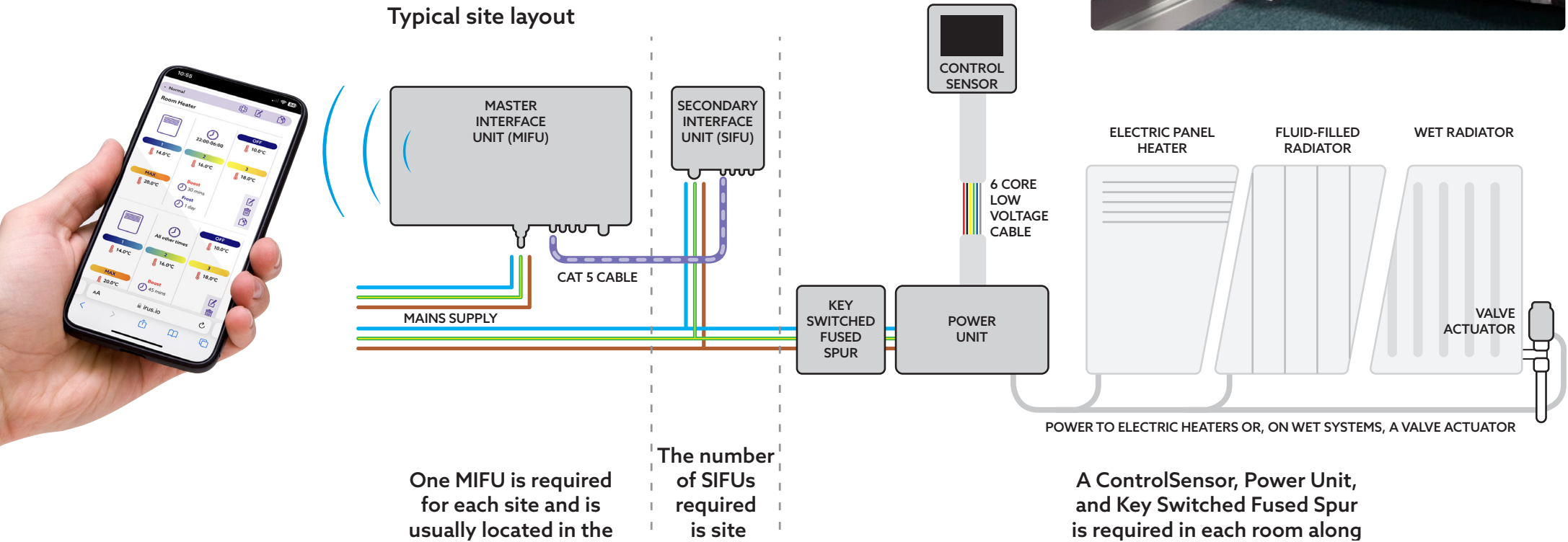

The ControlSensor is used to receive instructions within the room from the Irus Portal and affect the energy input to the heat source.

The intuitive interface enables the room occupant to increase the room temperature by touching the 'Up' arrow which moves it to the next State. Touching the 'Down' arrow takes the control to the next lower state.

The heater/flame symbol indicates whether the heat source is on or off. The current state is displayed between the arrows.

Occupancy sensor

The ControlSensor has an integrated microwave sensor that detects movement. If no movement is detected within a pre-set time frame, heat input is reduced.

A warm welcome

The ControlSensor can be customised by displaying your company's logo and a personalised welcome message

Heater/Flame symbol shows whether the heat source is on or off

Up and Down arrows for heat input adjustment

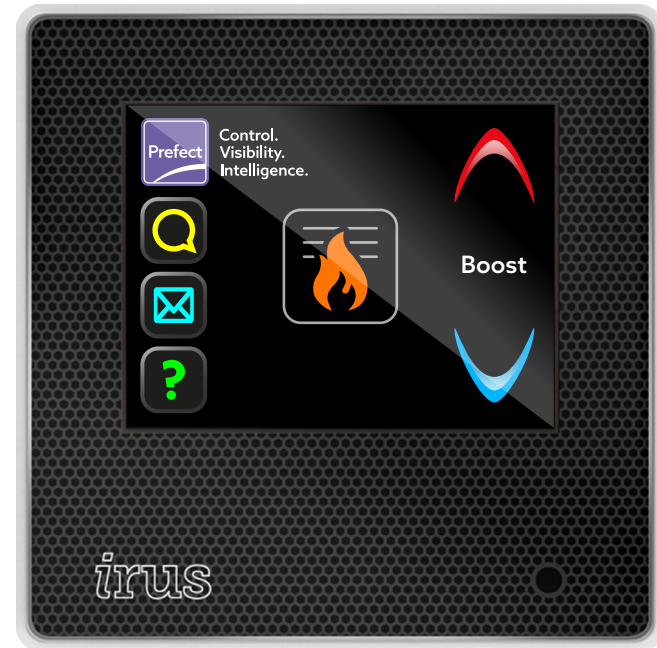

Nudges



Messages



Instructions

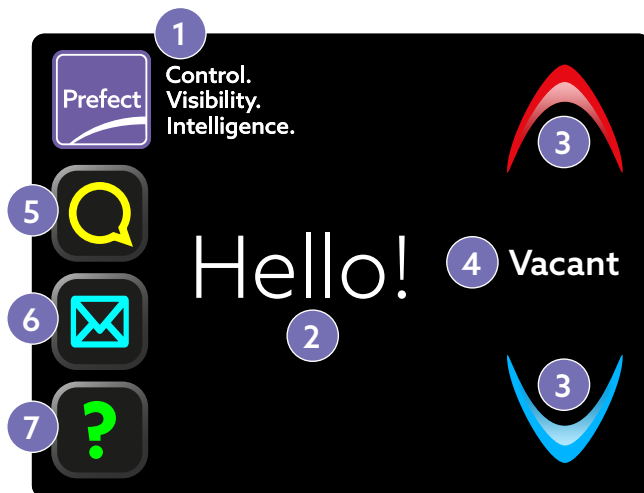

- 1 Customer logo
- 2 Welcome message
- 3 Control arrows (Up and Down)
- 4 Current state
- 5 Nudge communication access button
- 6 Message communication access button
- 7 Instruction information access button

Direct-to-Room communication

The ControlSensor displays communications sent from the portal. The symbols on the left hand of the screen provide communication to occupants. Either directly to individual rooms or en masse.

'Free-type' communication cannot be sent from one individual to another.

All communication is generated either; using data gathered from the system that is then interpreted using intelligent machine learning; or, from templates chosen by the system user to inform room occupants of upcoming event/notifications.

Data at your fingertips

The portal is the heart of the Irus system. This secure, intuitive interface provides complete visibility of all your property, whether a single block or a national estate.

This **Landing Page** shows all the buildings you have access to. You can choose the software tool you need to use to explore your site. News about the portal can be viewed here along with training and 'how-to' instructional videos.

Click on the **Controller** button and you can see the current conditions in any individual room; Make adjustment to temperature and time profiles; View historical data, and even test the heat source in a specific room.

Choosing the **Reporter Suite** within Controller provides access to custom reports, from where, for example, average temperature data is collated, or issues such as humidity become very clear.

The **Optimiser Dashboard** provides suggestions for 'quick-wins' such as highlighting unoccupied rooms using an unsuitable profile. Switching these will instantly improve energy efficiency.

The **Investigator*** tool presents a birds-eye view of your site. Specific observations let you drill down from block, to floor, to flat, to room to identify issues such as the use of supplementary heaters, high humidity, or an overview of occupancy.

*Investigator is a subscription service.

The news section keeps users up to date with Portal developments.

An archive for instruction and training videos.

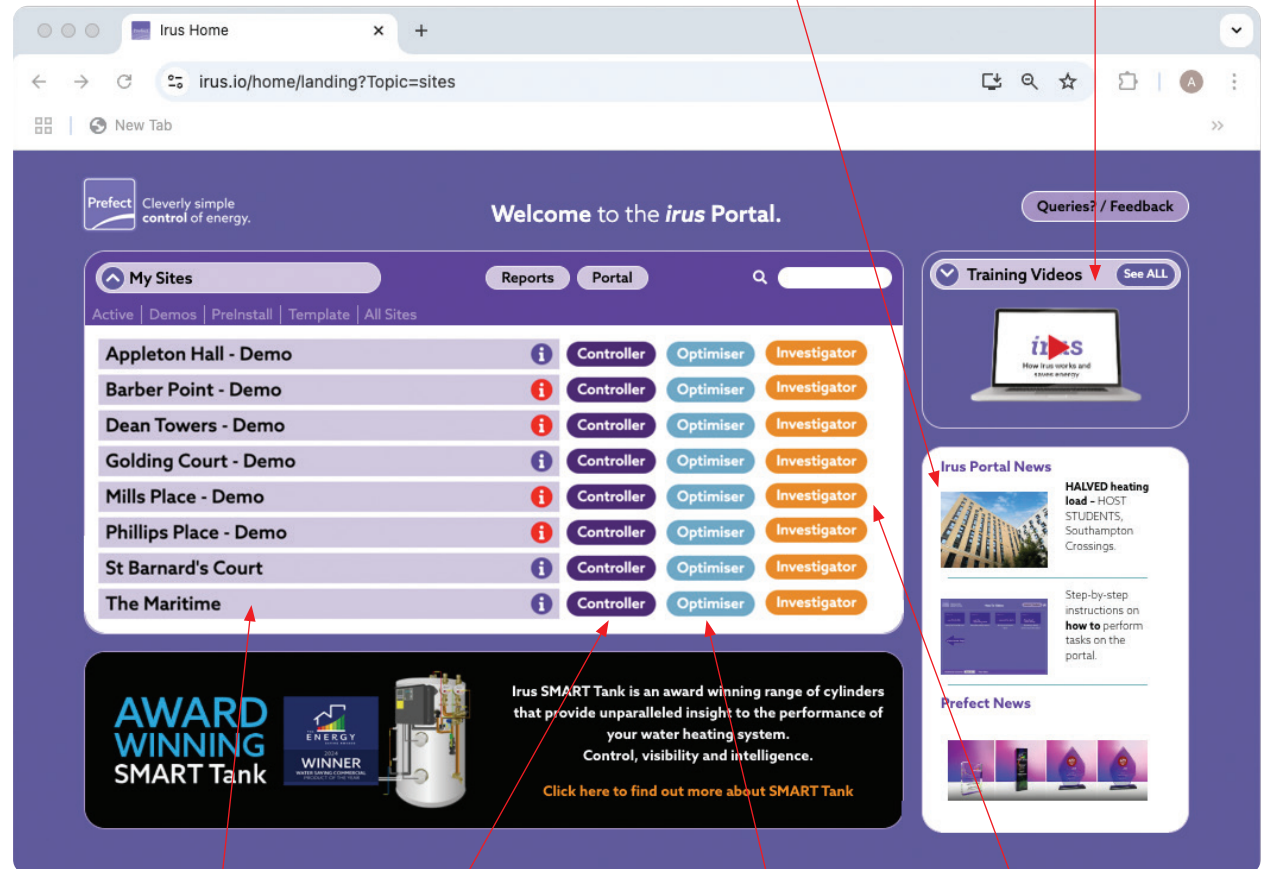

These are all the sites this user has access to.

Controller is the control tool for room conditions, water heating, leak detection, hob safety etc.

Optimiser is a tool that analyses data and makes recommendations for how to maximise operational efficiency.

Investigator is a tool that provides an overview of the site, but pinpoints where issues may be arising.

Controller presents all the information gathered from individual rooms and other control devices within the ecosystem in one easy to understand dashboard.

From here you view the rooms current temperature, test the heat source, and see whether the room is occupied.

Profiles can be adjusted and a timeline graph shows the days performance of heating and environmental conditions within the space.

The current room temperature.

Heater test button

ControlSensor status.

Instantaneous data for temperature, setpoint, humidity, light, sound pressure and current being drawn.

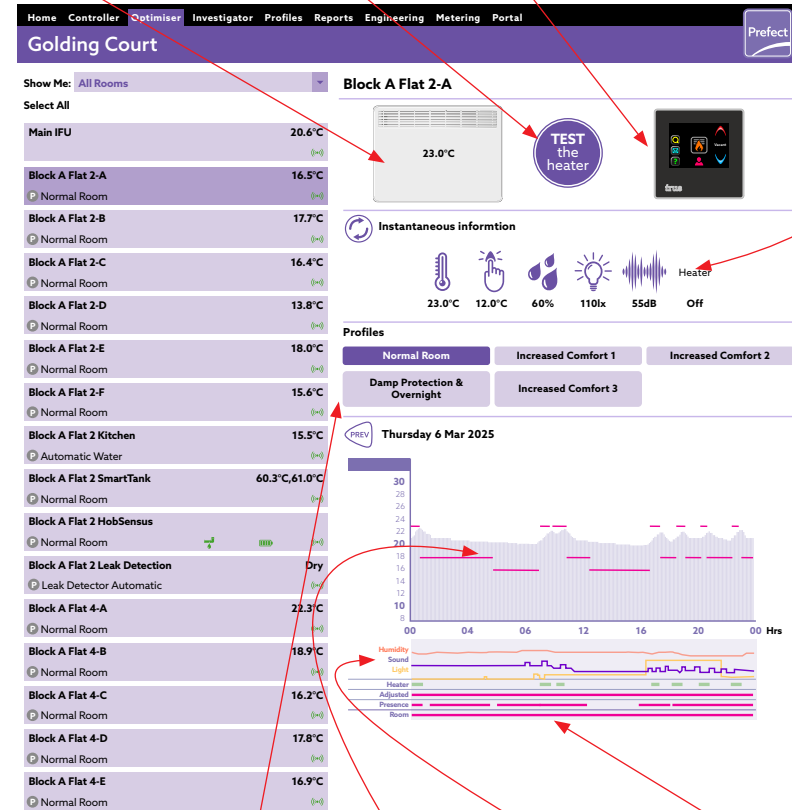
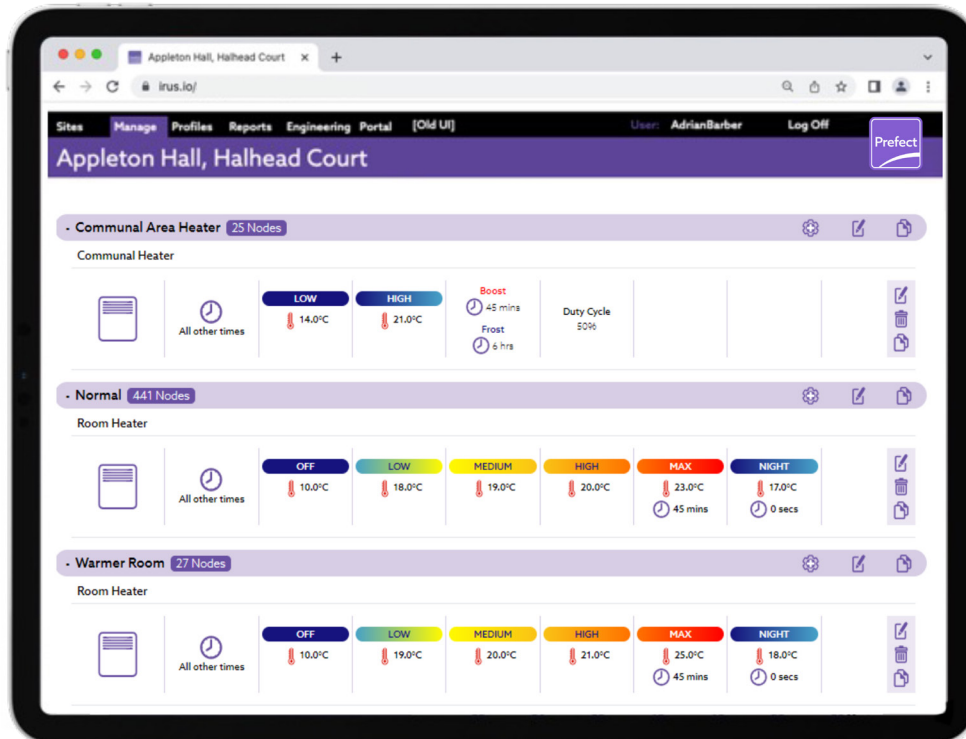

All the ControlSensors, room, tank, kitchen etc. are accessed from this list.

Profiles available for this site.

Timeline showing temperature and setpoint throughout the day.

Humidity, Lux and dB levels.

Heater operation, occupancy and profile.

Optimiser provides a prioritised list of the most pressing issues affecting your site's efficiency. It highlights 'quick wins' and offers clear recommendations to address problems such as:

- Unusually high energy consumption
- Rooms exceeding the maximum temperature set by the heating profile
- Heating faults or offline rooms

Quick access to metrics, including:

- The number of rooms deviating from the standard heating profile
- The percentage of unoccupied rooms

Using this data, Optimiser suggests easy-to-implement actions that help maintain efficiency and keep your building in optimal condition.

The screenshot displays the Prefect Optimiser interface for Golding Court. The top navigation bar includes 'Home', 'Controller', 'Optimiser', 'Investigator', 'Profiles', 'Reports', 'Engineering', 'Metering', and 'Portal'. The main header shows 'Golding Court' and the Prefect logo. Below this, a 'SITE: GOLDING COURT' section features tabs for 'SpaceHeat', 'SmartTank', 'LeakDetect', 'HobSenseus', 'UtilityMeter', and 'WaterSense'. The 'INSIGHTS' section contains six cards:

- HEATING FAULTS:** Shows 8 rooms with heating faults over 48 hours. Includes a bar chart and a history graph for 90 days.
- HUMIDITY:** Shows 0 rooms offline over 48 hours. Includes a bar chart and a history graph for 90 days.
- SUPPLEMENTARY HEATERS:** Shows 9 rooms exceeding the profile over 28 days. Includes a bar chart and a history graph for 90 days.
- ENERGY USE:** Shows 'Action Required' for the top 10% energy users last month. A red box indicates that these users are consuming more than the Irus benchmark. A green box shows a potential saving of £000.00 per year if they achieve the median value.
- HEATING PROFILES:** Shows 86% of rooms using the standard profile (LIVE), 82% (28 DAYS), and 78% (6 MONTHS AGO). A benchmark of 97% is shown for the average of 83 associated sites.
- UNOCCUPIED ROOMS:** Shows 62 rooms unoccupied (LIVE). Includes a bar chart and a history graph for 28 days.

Each insight card includes a 'GUIDANCE' section with specific recommendations and buttons for 'REPORT' and 'ROOMS'.

Investigator provides a snapshot of real time data and enables you to pinpoint where issues may be occurring.

All alerts can be viewed in one place along with the ability to generate reports for each data point. This helps to understand where hot or cold spots are within a building, occupancy patterns, noise levels, and trend analysis to target problematic areas.

Investigator can be used locally to address specific issues and understand intra-building issues but also centrally to help guide policy direction and decisions.

Rooms with issues highlighted on plan.

Choice of elevation or plan view.

Highlighting the floor location of issues.

Choice of floors to view.

Plan view.

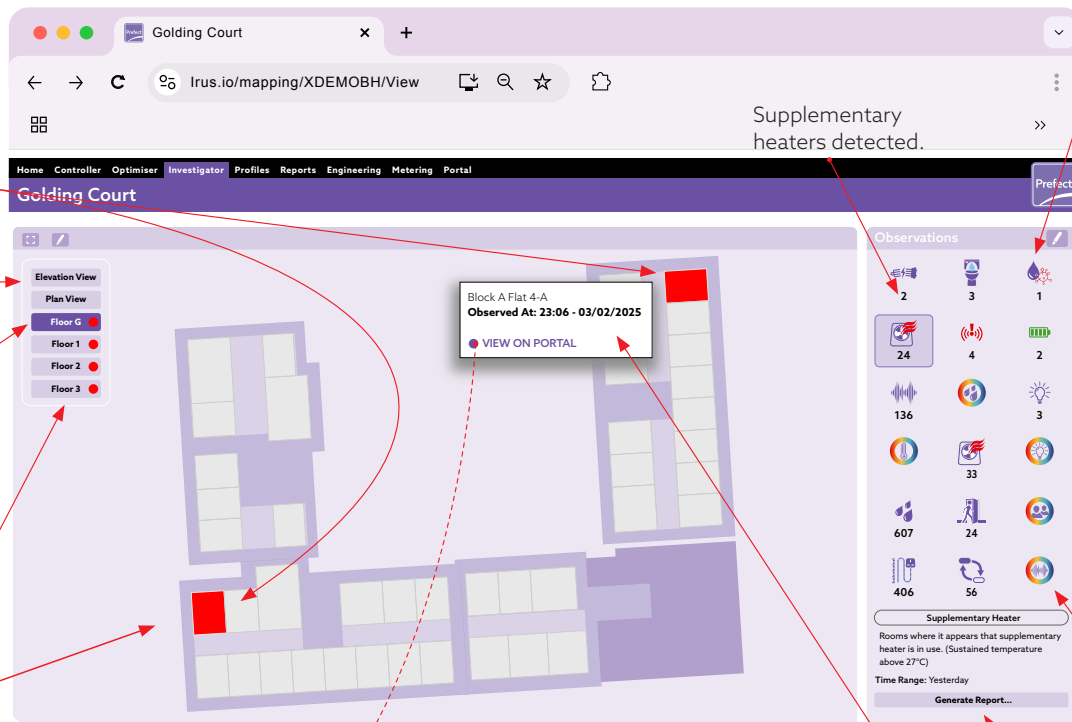

- Observation pane to choose from:
- faulty elements
 - leaking cisterns
 - water hygiene compliance
 - scalding risk
 - offline controls
 - low batteries
 - high noise level
 - lights left on
 - energy consumption
 - water setpoint failure
 - supplementary heater
 - vacant room
 - alternative profile.

- Plus colour maps for
- room temperature
 - humidity
 - light level
 - high noise level
 - room occupancy.

The ability to go to the Controller view of the specific room.

The ability to generate a report of issues detected.

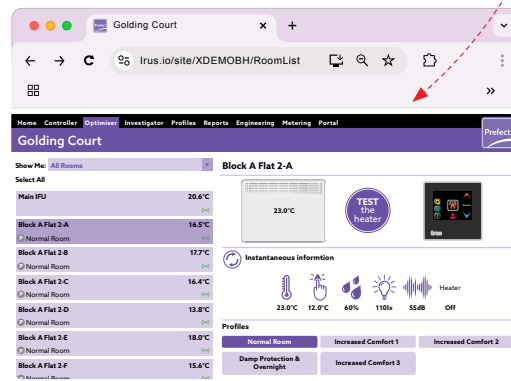

Controller view of the specific room

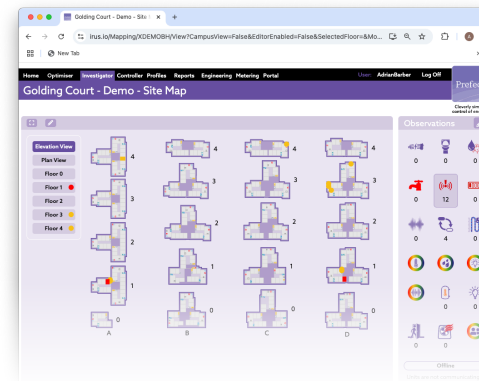

Alternative Elevation view of the site

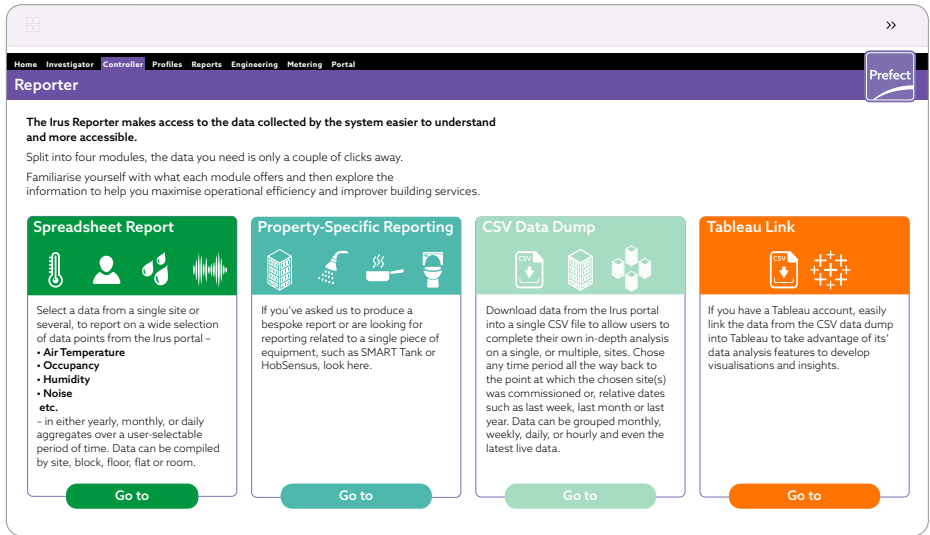

Reporter provides easy access to data from the Irus system. Four useful categories helps you grasp and handle the information you need in only a couple of clicks.

Spreadsheet Report gives you the opportunity to choose datapoints, timeframes, and whether you want to view a single site or compare multiple sites. Compare your own sites, or benchmark across the entire Irus UK estate.

Property-Specific reporting is where you can generate bespoke reports you have requested us to build.

If you are proficient in compiling masses of data into meaningful reports, use the **CSV Dump** to access raw data.

Finally create comprehensible visual displays of data by linking to the **Tableau** platform.

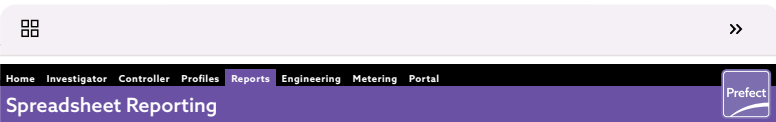

• Select 1 site or multiple sites for **benchmarking** purposes.

- Sites
Filter:
- Barbers Point
 - Golding Court
 - Mills Place
 - Dean Towers
 - Chaplin View

• Choose the data points for reporting.

Data Content	Average	Minimum	Maximum
Storage Temperature	<input type="radio"/>	<input type="radio"/>	<input type="radio"/>
Outlet Temperature	<input type="radio"/>	<input type="radio"/>	<input type="radio"/>
Supply Temperature	<input type="radio"/>	<input type="radio"/>	<input type="radio"/>
Return Temperature	<input type="radio"/>	<input type="radio"/>	<input type="radio"/>
<hr/>			
Water Volume	Hot	Cold	Total
<input type="radio"/> Total Energy	<input type="radio"/>	<input type="radio"/>	<input type="radio"/>
<input type="radio"/> Tundish Leaks	<input type="radio"/>	<input type="radio"/>	<input type="radio"/>

• Choose from set time periods or customisable dates.

Date Range

Fixed Dates:

Relative Dates:

Last Year Last Month Last 28 Days Last Week Last 7 Days

• Select how data will be grouped. From a full site down to individual rooms, daily, monthly or annual display.

Sheet Grouping

Site Year

Column Grouping

Year Month Day
(Approximately 0 columns will be needed per sheet)

Row Grouping

Group by:

Site Block Floor Flat Room

Subtotal:

(Approximately 46 rows will be needed on the longest sheet)

• Use the 'colour map' feature to help highlight potential issues.

Enhancements

Add Blue-Red Colour Map

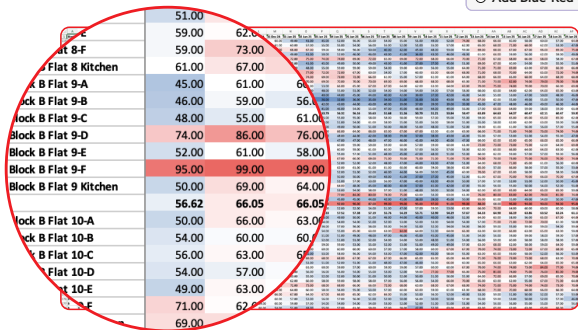

Generate Spreadsheet

EXAMPLE: The report generated for average humidity on a particular floor shows clearly there is an issue in **Block B, Flat 9-F**, where the humidity has consistently been high for many days.

Nudges

Nudges are information generated from individual room data collected by the **Irus System**.

Nudges are designed to encourage energy/utilities efficiency by affecting behavioural change.

The Irus System does not know a room occupant's identity and cannot link a room with an individual.

The messages contain information pertaining to consumption, room conditions or are simply advisory.

Any of the data collected by Irus can be used to trigger a nudge i.e. **energy use, humidity, light, sound pressure, occupancy, CO₂* etc.**

The dots under the text indicate how many Nudges there are to read. Subsequent nudges are read by swiping the screen.

Nudges will remain viewable until the featured issue/condition (i.e. humidity) is resolved, or when a specified time frame elapses. (*Optional)

Messages

Messages are information generated by **Irus System Users** for room occupants.

For example; Awareness of maintenance schedules/fire alarm drills, or that a parcel has been left in reception.

Templates are created for each message type. Administrators then customise the message with specific details, such as dates and times before sending to specific rooms or 'All'.

Instructions

Instructions are information to help occupants understand how their heating system works and why it is necessary. This can be a QR code leading to a video explaining the system or on-screen information about the control buttons etc.



The highlighted Nudge/Message/Instruction icon indicates which type of communication is being displayed. The numbers in the red circles indicate how many of each communication are available to read.

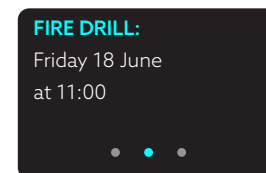
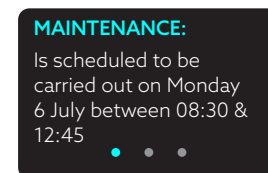
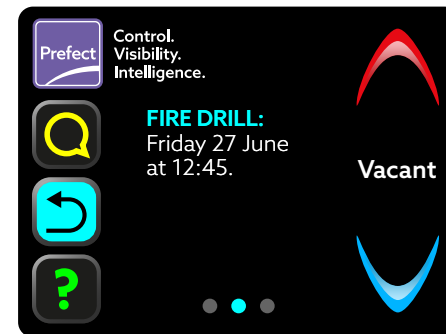
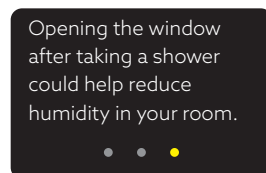
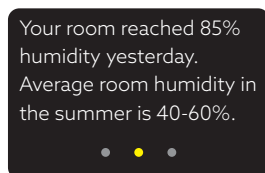
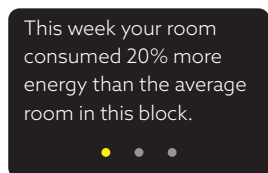

Typical Nudge/Message examples, however, these can be customised to site requirements

The *irus* ecoSystem

