



Electrical test applications for
DEFENCE



www.mktest.com

ENSURING MILITARY VEHICLES & EQUIPMENT ARE FIGHTING FIT

Our test systems are used across the entire defence supply chain - from connector manufacturers checking insulation performance to FAL testing the entire wiring of a fighter jet.

Equipment can also be deployed as part of your maintenance equipment, assisting in functional test and calibration tasks, and diagnosing electrical faults. Our portable solutions are designed for use in the field, whether on board a ship, submarine, or on land.

Customers in the defence sector include Babcock, BAE, Dassault, and Lockheed Martin.

Our systems combine powerful features with easy-to-use software and interfaces - designed to make testing simpler and faster.

Testing capabilities across our range include: Continuity resistance; short circuit; HV insulation resistance; HiPot (dielectric withstand); functional testing of active components; isolation testing; capacitance; and bond, loop & joint resistance testing.

This brochure provides an overview of test applications within the defence sector, and includes our recommended system solutions for every stage of the product's lifecycle.



MK Test Systems are authorised US DoD suppliers - our CAGE code is 8EGR1 and UEI is DMSXKFUC8ZK1.

CONTENTS

Our role within your business	2
Customers	3
Applications & recommended products	4
Products overview	5
Test management software	8
About MK Test Systems	9

OUR ROLE WITHIN YOUR BUSINESS

For over 30 years, we've provided test equipment ideally suited to the demands of vehicle and equipment production to some of the biggest defence contractors and military organisations around the world.

Our systems enable testing of all electrical systems; control systems and communications, and cabling in helicopters, ejector seats, military transport aircraft, satellites and launch systems.

By integrating the MK Test equipment with production line and production management systems, it's possible to achieve fast testing of wiring looms, harnesses and associated connectors, plus full function tests of active components on the production line, enabling any quality issues to be rectified immediately.

Defence equipment needs to perform in harsh environments and in situations where servicing and maintenance may not be a priority due to operational demands. Our portable solutions are designed for use in the field - whether on board a ship, submarine, or on land - and can be deployed as part of your maintenance equipment, assisting in functional test and calibration tasks, and diagnosing electrical faults.

Harness shop

Sub assembly

Final assembly

Maintenance

MK Test Systems in use on Airbus A400M wing assembly



SOME OF OUR DEFENCE CUSTOMERS



CUSTOMER CASE STUDIES & TESTIMONIALS



thyssenkrupp

Portable Automeg F1500 Harness Test System

ThyssenKrupp Marine Systems are the world market leader in submarines. Due to lack of space for standard rack-mounted configurations, they required a specialist portable harness test system for use on submarines at their Kiel shipyard.

Automeg Portable has now been rolled out (no pun intended) as a regular system configuration and is ideally suited to the restrictive conditions where testing is frequently required by customers in the defence sector.



Many of our customers in this sector wish to remain anonymous. We've provided the below application examples to demonstrate use cases whilst maintaining confidentiality.

BLRT Bond and Loop Resistance Tester



The customer has a number of repair centres in the US and Europe, providing MRO repair and overhaul services for their own aerospace components and systems.

A total of 6 BLRT tools are used at one of their UK sites, testing refueling pods for military aircraft.

Portable Automeg D1500 Harness Test System

We've been supplying this customer with portable wire harness test systems for over 10 years. The systems are ruggedised and portable for use on systems in remote locations.

Our unique diode return module enables single-end testing to be carried out, halving the number of interface cables required for field applications.



APPLICATIONS & RECOMMENDED PRODUCTS

Equipped Assembly / Function Testing

Automatic test solutions for electrical assemblies, including active components. Products: Automeg with Multibus module for function testing, Portable Automeg

Wire / Cable Harness Manufacturing

Automatic test solutions for electrical wire harnesses and cable assemblies. Products: Automeg, RTS.

Engine Manufacture & MRO

Electrical wire harness and components; electrical bond circuits, earth straps and shielded cables. Products: Automeg, Portable Automeg, BLRT, BLTU4

Final Assembly Line (FAL)

Automatic testing of complete vehicles and equipment. Products: Automeg, RTS.



Connector Manufacturing

Automatic testing of electrical connector assemblies. Products: Automeg.

Bond, Loop & Joint Testing

Automatic resistance testing to ensure low resistance current paths. Products: ExLRT, BLRT, BLTU4.

Field-Deployed Testing

Automatic testing for maintenance, calibration and faults in remote or field applications. Products: Portable Automeg, ExLRT.

WIRE HARNESS TEST SYSTEMS

We offer an extensive range of electrical harness test systems, and have the modular flexibility to customise all models to suit your exact requirements.

Our sales team can help you configure the perfect spec for your needs, but this guide is a useful starting point. As an overview, all models offer the following features:

- Continuity resistance measurement, low voltage isolation test (short circuit), and high voltage DC insulation resistance testing as standard.
- Optional high voltage AC HiPot testing, capacitance measurement LCR modules
- Optional function test stimulus switching modules and power supplies to enable actuation and function test. Note: This option is suitable for testing a small number of active components in the assembly under test. For testing larger amounts of active components, we recommend a full function test system from our E or M series.
- Integration with a range of third party sources, scopes and measurement modules.
- MKAT, our test management software which combines ease of use with powerful test program creation and management capabilities. Learn more about MKAT on page 8.

All systems can be configured to suit your operation and application, from static rack cabinets to heavy duty mobile cabinets suitable for harness shop floor or final assembly environments. We also offer distributed and fully portable systems.

Our range of Automeg models break out into the following groups:

T Series: This model is named T for two wire, because our T series applies 2 wire continuity resistance measurement. If your test requirement demands a high test point count and only needs continuity resistance measurement down to 0.1Ω , then the T series is your entry level, lowest cost, automatic test option.

F Series: The F series is our dedicated 4 wire test Kelvin measurement solution. As per the T model range, F stands for four wire. When your continuity and resistance measurements need to be milliohm-accurate, the dedicated 4 wire F system guarantees you the best possible accuracy. This series is therefore ideal for testing critical cables, components, shielding joints and low resistance connections.

D Series: The D series is our most popular model for standard electrical harness testing. It offers both 2 wire and 4 wire resistance measurements, as well as the ability to mix these modes in a single test program. The D series models can handle a mix of resistance measurements down to $2m\Omega$. The result is an extremely flexible system which enables rapid automatic testing of complex assemblies.

Continued over the page...



E Series: The E series is our entry level multibus function test solution. If your product has active components or you might need to function test active assemblies in the future, the E series offers both measurement and function test capability. Each E series relay card can be used as either a measurement card or a functional stimulus switching card. The only restriction with the E series is that the card can be used for either measurement or stimulus switching during a subtest, so you need to plan your test interface to enable a full functional test. The E series is your ideal solution if active component density is low or your designs are stable.

M Series: The M Series offers the highest level of flexibility. These systems can be used in both 2 wire and 4 wire kelvin measurements and they can also deliver functional stimulus from any test at any time. As with the E series, the card can be used for either measurement or stimulus switching during a subtest. The M series simplifies your interface design as each interface channel can be used to both measure and stimulate, so no need for a complex Y cable interface. For example, when testing a contactor the system measures the resistance of a coil and then stimulates the coil using the same test points and same interface wire. It then measures the change in contact resistance concurrently. If your active component density is high, or your active product format is flexible then the M series is your ideal system.

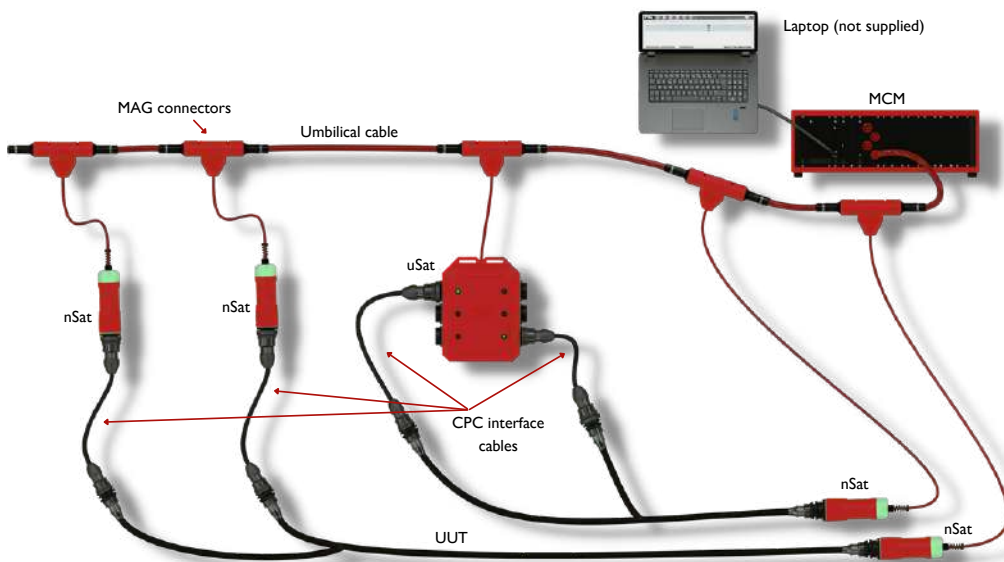

RTS: Separate from the Automeg range, RTS is an entirely different type of wire harness test system.

It's a miniaturised, modular product which brings the test points directly to the unit under test, thereby eliminating up to 90% of interface cables typically required with a traditional system.



The key to understanding which system is the right one for you is knowing your test requirements.

Ideally, you'll be able to tell us the following details:

- Number of test points (to test a single 2 wire if required, 4 for kelvin measurements)
- Maximum voltage required for AC and DC insulation tests
- If you require a static, mobile or distributed system
- Your interface requirement – standard or custom
- Is energisation required? If so, what is the maximum current and voltage?
- Do you require high current switching (more than 2 Amps)?
- Do you need to test capacitance?

Our sales team can advise on the best system for you and recommend any additional modules.

BOND & LOOP RESISTANCE TESTING

We've developed our range of bond and loop resistance testers specifically to resolve the inherent issues with the legacy 'yellow box' LRT equipment.

Our range of tools are lightweight, operator-friendly and we have models approved for use by Boeing, Airbus and COMAC.

Whether you need a simple loop resistance tester or need to carry out full Bond, Loop & Joint testing, we have a suitable tool for you.

The comparison table below shows the differences between our models and the 'yellow box' LRT.



	LRT (THE YELLOW ONE)	BLRT / BLTU4 (THE ORANGE ONES)	EXLRT (THE RED ONE)
IS CLASSIFICATION	Class 1 Division 2 (Flammable gases not likely to exist)	N/A	Class I, Division 1 (Flammable gases exist all the time)
OPERATORS	2	1	1
TEST MODES	Manual	Manual & automatic	Manual & automatic
PROGRAMMABLE	No	Yes	No
USER INSTRUCTIONS	No	Full graphics in auto mode	Text instructions in auto mode
RESULTS	None	Auto save to tool & network	Auto save to tool & network
CALIBRATION	Turn-around time 2 months	Turn-around time 1 week	Turn-around time 1 week
WEIGHT	17kg / 37.5lbs	7kg / 15.5lbs	3kg / 6.6lbs
BOND / LOOP / JOINT	No / Yes / Yes	BLRT/BLTU4 - Yes / Yes / Yes	No / Yes / Yes
APPROVAL	Boeing	Airbus & Boeing	Airbus (via equivalency) & Boeing

MKAT TEST MANAGEMENT SOFTWARE

"From creation of test programs through to fault diagnostics, MKAT supports your business needs whilst giving engineers control over testing."

In our 2022 survey, 87% of our customers said MKAT software was easy to use.

"When combined with our Multibus test module, the Active APG tool provides world leading function test capability."

All MK Test systems run on MKAT, our test management software combining our renowned ease of use with highly advanced technology. It's all driven by our goal of simplifying the test process for our customers.

Simplifying the testing process at every stage

Whilst we pride ourselves on the robustness and reliability of our hardware, it is our software which makes our systems stand out from our competitors.

We've spent years developing and refining our software to make it simple to use yet powerful.

Creating the test program

Create a test program without having to learn a programming language. We use standard wiring input of Netlist, connection tables and interface adaptor tables to create test programs.

Test parameters such as current, voltage, resistance and dwell can be set by test, group or connection. Tests are enabled or disabled by simple click of a button.

APG

Automatic Program Generation (APG) is included in the MKAT test management software as standard.

Our APG toolset allows the user to re-map fields and use their existing data formats.

Ease of use

Creation of the test program is only the start – our software makes the test process simple.

Operator instructions and prompts can be easily added to any program, and automatic test reports and fault diagnosis tools inform the operator of the nature of the failure and how to fix or retest the fault.

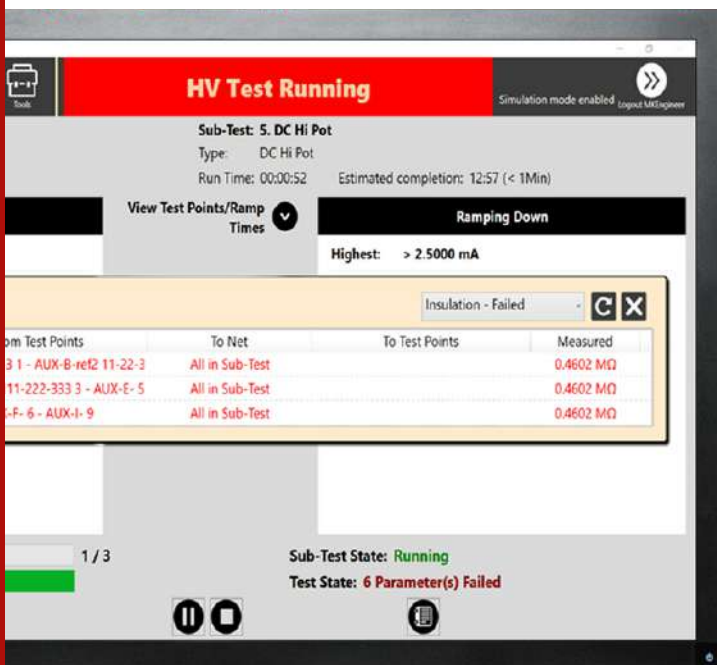

ABOUT US

We've been designing and manufacturing automatic electrical test equipment for 30 years. In that time, we've provided systems to customers around the world, in the following industries:



- Aerospace
- Automotive
- Defence (US DoD CAGE code 8EGR1)
- Industrial, Power & Control
- Subsea
- Trains

Our range of products enable rapid, automatic testing of engines, wiring harnesses, slip rings and other vital components.

We can work with you wherever testing is undertaken, at any stage of the product lifecycle. This may be at component manufacture stage - providing quality assurance to subcontractors - or at the final assembly stage, ensuring complete confidence in the final product. Beyond this, we also provide testing solutions for MRO and servicing.

TALK TO US

Our UK head office is supported by satellite locations in the US and Hong Kong. With our large global network of reps and distributors, you can be assured of local support, sales and training.

For your local contact details, please visit our website, www.mktest.com.

FOLLOW US

