

Motor Drives, Electric Motor
Spindle Drives and Accessories



WE GET IDEAS MOVING

The spirit of innovation and a sense of ideas beyond the familiar has made us into a pioneering company over more than 185 years.

For a quarter of a century, we have been offering customized drive solutions for office and workplace workstations, as well as for shading systems and building technology.

Through our tradition of innovation, we have succeeded in establishing ourselves as a specialist and problem-solver in numerous areas.

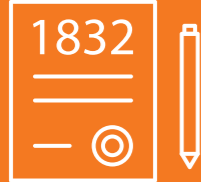

Over 185 years' experience



More than 60 standard solutions for four different market segments



100% Made in Black Forest

THE RIGHT PRODUCT FOR EACH APPLICATION

Motor Drives

- Page 04 3112 Motor drive
- Page 06 3121 Motor drive
- Page 08 3130 Motor drive
- Page 10 3133 Motor drive
- Page 12 3133.48 Motor drive
- Page 14 3143 DC-Motor drive
- Page 16 4773 Motor drive
- Page 18 4778 Motor drive for through going spindle
- Page 20 4779 Motor drive for through going spindle

Electric Motor Spindle Drives

- Page 22 3120 Inline spindle drive
- Page 24 3122 Inline spindle drive
- Page 26 3146 Drive with throughgoing spindle
- Page 28 4114 Electric drive with synchronous telescopic spindle
- Page 32 4640 Electric spindle drive
- Page 34 4642 Electric spindle drive
- Page 36 4643 Electric spindle drive

Accessories

- Page 38 Control box Compact
- Page 40 Hand control and motor cables
- Page 42 Profile tubes - Profile rods



Motor drive 3112

Description

Compact 12 V DC motor with worm gear and through going hexagon socket. A cable with AMP plug and an integrated Hall sensor allows easy and secure control of the entire system. Easily adaptable via hexagon socket and anchor points.

Special features

- Two integrated Hall sensors for measurement of the revolutions and direction of rotation
- Through going hexagon socket in wrench widths 6 mm and 9 mm
- Good self-locking properties
- 100 mm motor cable with connector included

Variant key

Variants are formed by different wrench widths.

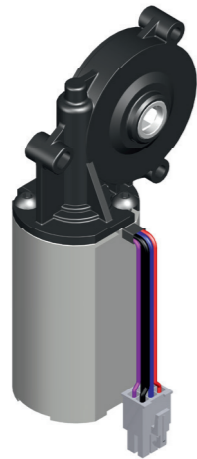

Technical data

Model	3112.00-1009	3112.00-1006
Motor	DC motor 12 V	DC motor 12 V
Sensor/Power supply	Hall/5 V DC/0.3 A	Hall/5 V DC/0.3 A
Protection class	IP30	IP30
Idle running speed	120 rpm (12 V)	120 rpm (12 V)
Duty cycle idle speed	20% (at 5 min.)	20% (at 5 min.)
Duty cycle nominal load*	20 s ON/ 240 s OFF	20 s ON/ 240 s OFF
Rated torque*	2.8 Nm	2.8 Nm
Short term peak torque (<1s)	6 Nm	6 Nm
Input	hex 9 mm	hex 6 mm

* Load determined for service life of 10,000 double strokes

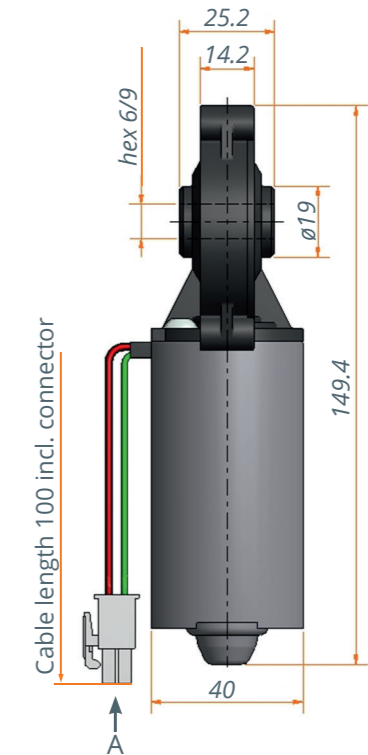
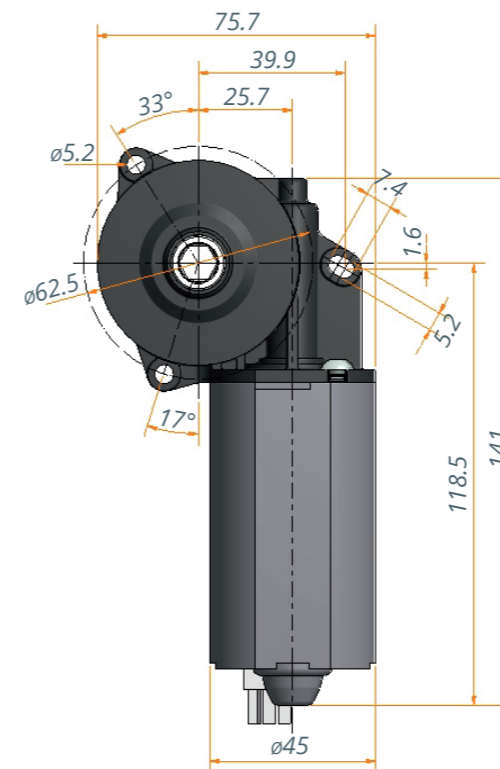

Pin assignment

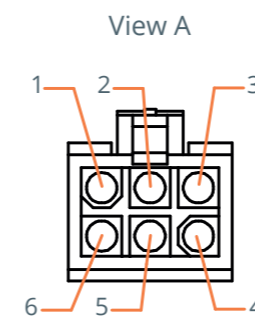

1. Motor black - 0,75 mm²
2. Motor blue + PIN type AMP170364
3. Hall sensor red +5V
4. Hall sensor violet, output 2 0,25 - 0,35 mm²
5. Hall sensor black - PIN type
6. Hall sensor green, output 1 AMP170363

Mounting example:

Screw M5x20
DIN 7380 (3x)

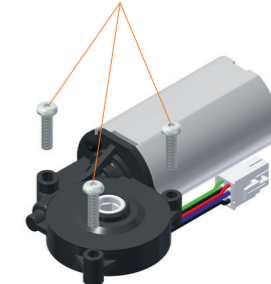

Technical notes

- The drive requires a suitable 12 V controller.
- The drive working range (nominal torque) is determined for a service life of 10,000 double strokes.
- By using a controller with a short-circuit brake the holding torque position of the drive can be increased.

Technical data for motor drive 3112 in combination with spindle unit 3130.14

	with 3130.14-V1XEXXXHXXX	with 3130.14-V2XEXXXHXXX
Type of spindle	TR14x3 RH	SG14x16P4 RH
Duty cycle nominal load* & Stroke 500 mm	90 s ON/ 540 s OFF	25 s ON/ 300 s OFF
Max. lifting force F₁*	900 N	400 N
Max. pulling force F₂*	500 N	400 N
Stat. self locking	150 kg	60 kg

* Load determined for service life of 10,000 double strokes

Motor drive 3121



Description

Powerful 24 V DC motor with 2-stage worm gear with through going hexagon socket on the output.
The motor cable with AMP plug and the integrated Hall sensors allow secure connection and exact positioning of the entire system.

Special features

- Two integrated Hall sensors for measurement of the revolutions and direction of rotation
- Through going hexagon socket in wrench widths 6 mm, 7 mm, 8 mm
- Good self-locking properties
- 220 mm motor cable with connector included
- Can be combined with most Ketterer spindle systems

Variant key

The variants are formed by the different wrench widths of the through going hexagon socket.
The design with fork head (see spindle drive 3120.00) is available upon request.

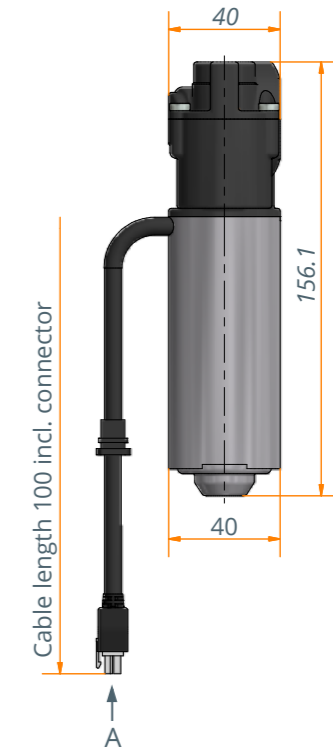
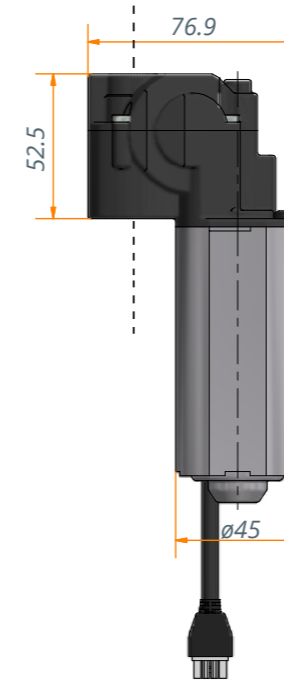

Technical data

Model	3121.00-2002	3121.00-2007	3121.00-1008
Motor	DC motor 24 V	DC motor 24 V	DC motor 24 V
Sensor/Power supply	Hall/5 V DC/0.3 A	Hall/5 V DC/0.3 A	Hall/5 V DC/0.3 A
Protection class	IP30	IP30	IP30
Idle running speed	150 rpm (24 V)	150 rpm (24 V)	150 rpm (24 V)
Duty cycle idle speed	20% (at 5 min.)	20% (at 5 min.)	20% (at 5 min.)
Rated torque*	3 Nm	3 Nm	3 Nm
Duty cycle nominal load*	20 s ON 240 s OFF	20 s ON 240 s OFF	20 s ON 240 s OFF
Short term peak torque (<1sec)	4.5 Nm	4.5 Nm	4.5 Nm
Input	hex 6 mm	hex 7 mm	hex 8 mm

* Load determined for service life of 10,000 double strokes

Pin assignment

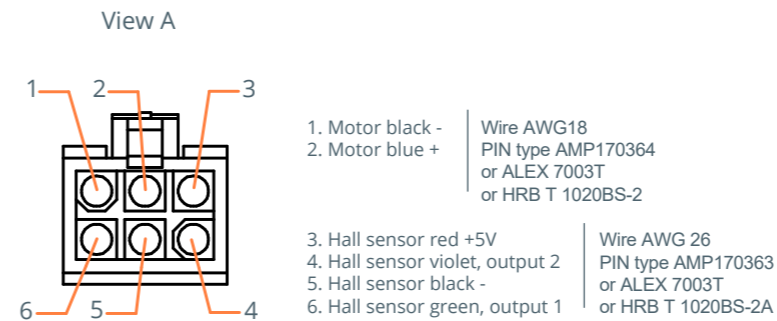

Installation position/mounting

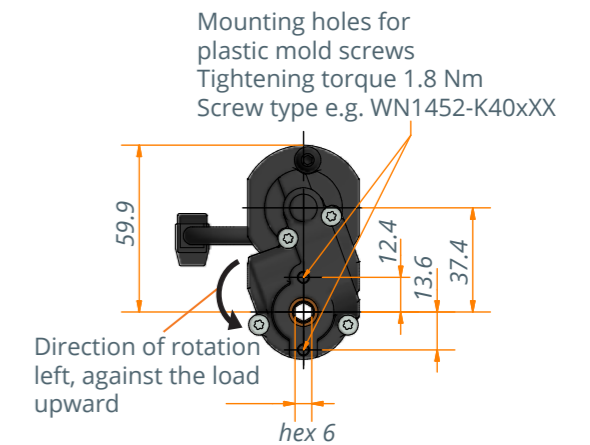

Technical notes

- Please note the correct installation position of the drive! The drive is correctly mounted when it turns counterclockwise under load (see installation position/mounting).
- The drive working range (nominal torque) is determined for a service life of 10,000 double strokes.
- Through the controller* the system is regulated such that the speed in the entire drive working range is kept as constant as possible.
- By using a controller with a short-circuit brake the holding torque position of the drive can be increased.

* In combination with LogicData control box Compact-3

Motor drive 3130



Description

Compact 24 V DC motor with worm gear and continuous hexagon socket. Optimized sound characteristics due to elastic coupling and vibration damping fastening elements. Although the drive was developed for ergonomic table applications, it can be used in many other fields. The drive is designed and tested for axial pressure load. A cable with AMP plug and an integrated Hall sensor allows easy and secure control of the entire system.

Special features

- Vibration and sound-damped design through mechanical decoupling of the spindle system
- Two integrated Hall sensors for measurement of the revolutions and direction of rotation
- Through going hexagon socket in wrench widths 6 mm and 7 mm
- Good self-locking properties
- 100 mm motor cable with connector included
- Can be combined with most Ketterer spindle systems

Variant key

The variants are formed by the different wrench widths and by fastening variants with and without fastening plate (Variant A or Variant B).

Technical data

Model	3130.00-1002 Variant B	3130.00-1003 Variant B	3130.00-2002 Variant A	3130.00-2003 Variant A
Motor	DC Motor 24 V	DC Motor 24 V	DC Motor 24 V	DC Motor 24 V
Sensor/Power supply	Hall/5 V DC/0.3 A	Hall/5 V DC/0.3 A	Hall/5 V DC/0.3 A	Hall/5 V DC/0.3 A
Protection class	IP30	IP30	IP30	IP30
Idle running speed	120 rpm (24 V)	120 rpm (24 V)	120 rpm (24 V)	120 rpm (24 V)
Duty cycle idle speed	20% (at 5 min.)	20% (at 5 min.)	20% (at 5 min.)	20% (at 5 min.)
Rated torque*	3.5 Nm	3.5 Nm	3.5 Nm	3.5 Nm
Duty cycle nominal load	20 s ON 240 s OFF	20 s ON 240 s OFF	20 s ON 240 s OFF	20 s ON 240 s OFF
Short term peak torque (<1s)	6 Nm	6 Nm	6 Nm	6 Nm
Input	hex 6 mm	hex 7 mm	hex 6 mm	hex 7 mm

* Load determined for service life of 10,000 double strokes

Variant A with mounting plate

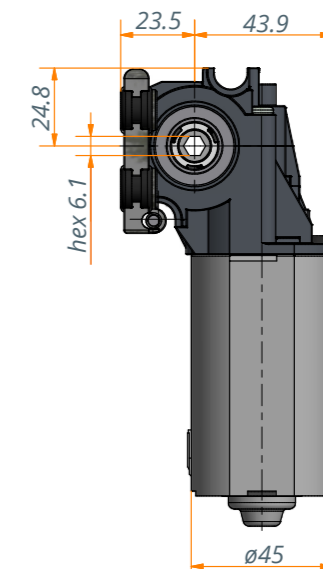
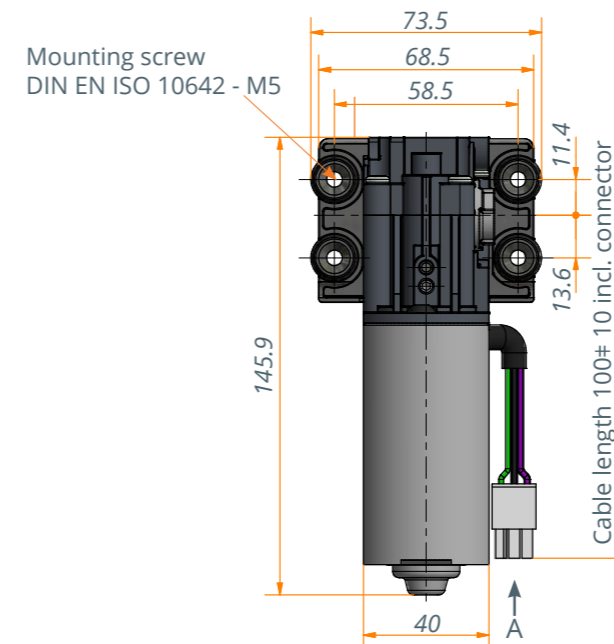

Variant B without mounting plate

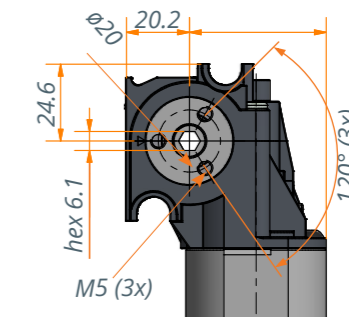
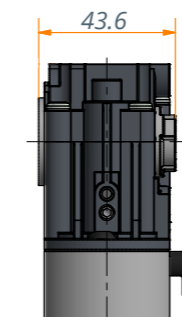

Pin assignment

View A

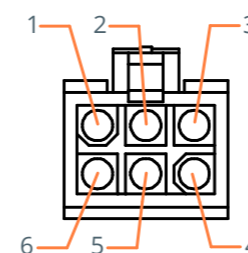

- | | |
|---------------------------------|--------------------|
| 1. Motor black - | Wire AWG18 |
| 2. Motor blue + | PIN type AMP170364 |
| | or ALEX 7003T |
| | or HRB T 1020BS-2 |
| 3. Hall sensor red +5V | Wire AWG 26 |
| 4. Hall sensor violet, output 2 | PIN type |
| 5. Hall sensor black - | AMP170363 |
| 6. Hall sensor green, output 1 | or ALEX 7003T |
| | or HRB T 1020BS-2A |

Technical notes

- The drive working range (nominal torque) is determined for a service life of 10,000 double strokes.
- Through the controller* the system is regulated such that the speed in the entire drive working range is kept as constant as possible.
- By using a controller with a short-circuit brake the holding torque position of the drive can be increased.

* In combination with LogicData control box Compact-3

Motor drive 3133.00



Description

Compact 24 V DC motor with worm gear and continuous hexagon socket. Although the drive was developed for ergonomic table applications, it can be used in many other fields. A cable with AMP plug and an integrated Hall sensor allows easy and secure control of the entire system.

Special features

- Two integrated Hall sensors for measurement of the revolutions and direction of rotation
- Through going hexagon socket in wrench widths 6 mm, 7 mm, 9 mm
- Good self-locking properties
- Low noise
- 1000 mm motor cable with connector included
- Can be combined with all Ketterer spindle systems

Variant key

The variants are formed by the different wrench widths.

Technical data

Model	3133.00-0016	3133.00-0017	3133.00-0011
Motor	DC motor 24 V	DC motor 24 V	DC Motor 24 V
Sensor/Power supply	Hall/5 V DC/0.3 A	Hall/5 V DC/0.3 A	Hall/5 V DC/0.3 A
Protection class	IP30	IP30	IP30
Idle running speed	120 rpm (24 V)	120 rpm (24 V)	120 rpm (24 V)
Duty cycle idle speed	20% (at 5 min.)	20% (at 5 min.)	20% (at 5 min.)
Rated torque*	3.5 Nm	3.5 Nm	3.5 Nm
Duty cycle nominal load	20 s ON 4 min OFF	20 s ON 4 min OFF	20 s ON 4 min OFF
Short term peak torque (<1sec)	5 Nm	5 Nm	5 Nm
Input	hex 6 mm	hex 7 mm	hex 9 mm

* Determined at full load for service life of 10,000 double strokes

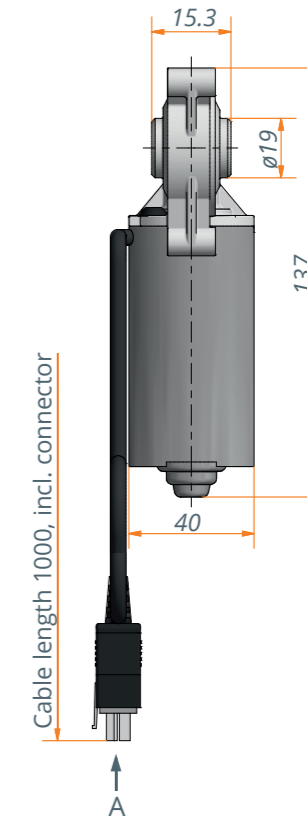
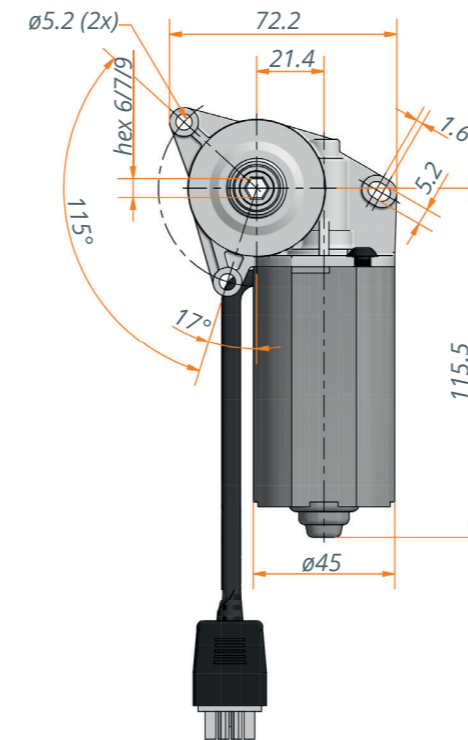

Pin assignment

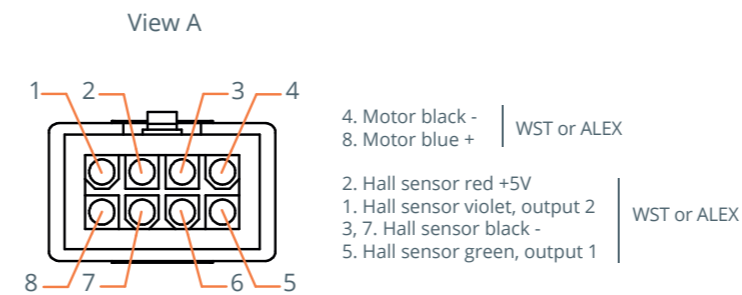

Technical notes

- To ensure secure operation the motor must be operated in the predefined installation position (see installation position/mounting).
- The drive working range (nominal torque) is determined for a service life of 10,000 double strokes.
- The connection position of the drive in the entire system with vibration damping elements can be beneficial. However, the functional reliability position of the drive in the application should be tested.

* In combination with LogicData control box Compact-3

Installation position/Mounting

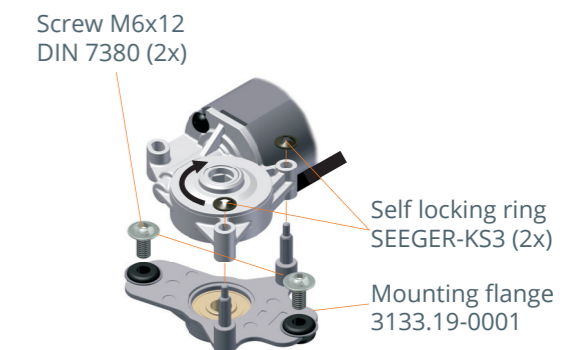

- Through the controller* the system is regulated such that the speed in the entire drive working range is kept as constant as possible.
- By using a controller with a short-circuit brake the holding torque position of the drive can be increased.

DC-Motor drive 3143



Description

Powerful 24 V DC motor with worm gear and through going hexagon socket. Although the drive was developed for ergonomic table applications, it can be used in many other fields. A cable with AMP plug and an integrated Hall sensor allows easy and secure control of the entire system.

Special features

- Two integrated Hall sensors for measurement of the revolutions and direction of rotation
- Through going hexagon socket in wrench widths 6 mm, 7 mm, 9 mm
- Available as "power package" or as "high speed" variant
- 1200 mm motor cable with connector included
- Good self-locking properties
- Can be combined with all Ketterer spindle systems

Variant key

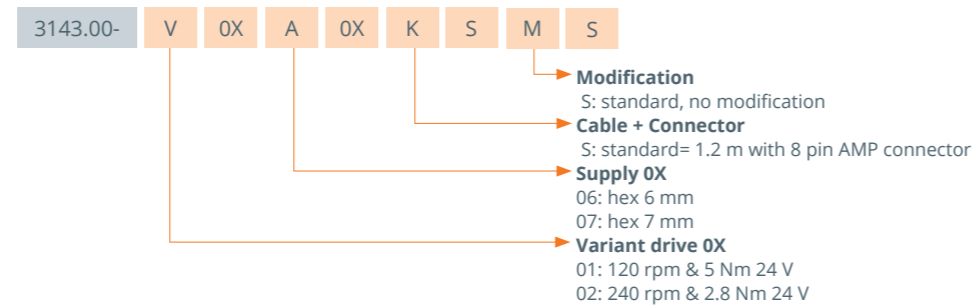

Technical data

Model	3143.00-V01A06KSMS	3143.00-V01A07KSMS	3143.00-V02A06KSMS	3143.00-V02A07KSMS
Motor	DC motor 24 V	DC motor 24 V	DC motor 24 V	DC motor 24 V
Sensor/Power supply	Hall/5 V DC/0.3 A	Hall/5 V DC/0.3 A	Hall/5 V DC/0.3 A	Hall/5 V DC/0.3 A
Electric current	5.5 A at 5 Nm	5.5 A at 5 Nm	4.2 A at 2.8 N	4.2 A at 2.8 Nm
Protection class	IP30	IP30	IP30	IP30
Idle running speed	115 rpm (24 V) 120 rpm *	115 rpm (24 V) 120 rpm *	230 rpm (24 V) 240 rpm *	230 rpm (24 V) 240 rpm *
Duty cycle idle speed	20% (at 5 min.)	20% (at 5 min.)	20% (at 5 min.)	20% (at 5 min.)
Rated torque*	5 Nm	5 Nm	2.8 Nm	2.8 Nm
Duty cycle nominal load**	20 s ON 240 s OFF	20 s ON 240 s OFF	20 s ON 240 s OFF	20 s ON 240 s OFF
Short term peak torque (<1s)	9 Nm	9 Nm	5 Nm	5 Nm
Input	hex 6 mm	hex 7 mm	hex 6 mm	hex 7 mm

* In combination with LogicData control box Compact-3
** Load determined for service life of 10,000 double strokes

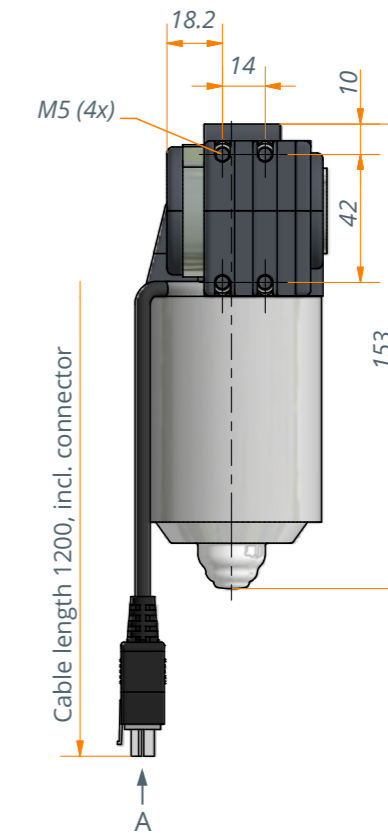
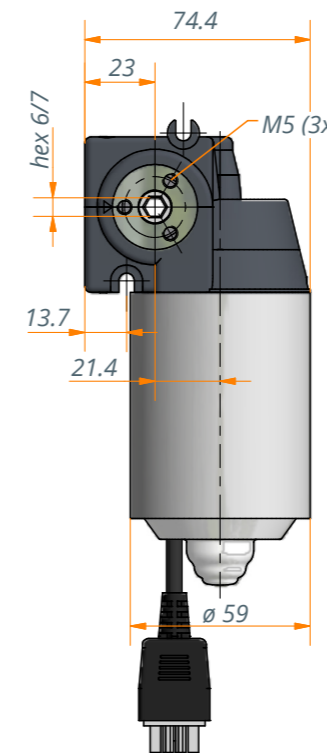

Pin assignment

View A

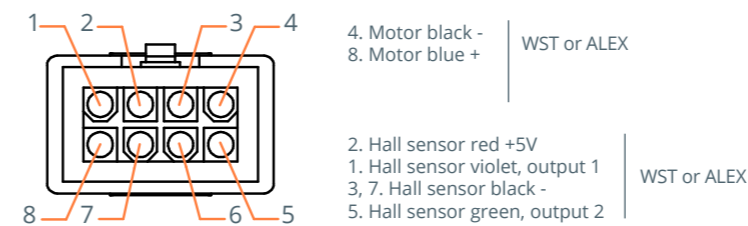

Technical notes

- The drive working range (nominal torque) is determined for a service life of 10,000 double strokes.
- Through the controller* the system is regulated such that the speed in the entire drive working range is kept as constant as possible.
- By using a controller with a short-circuit brake the holding torque position of the drive can be increased.

* In combination with LogicData control box Compact-3

Motor drive 4773

Description

Powerful 24 V DC motor with two worm gears and a planetary gear.
High reduction ratio makes precise control and position setting possible.

Special features

- Compact, precise gears for sophisticated position adjustment
- High reduction ratio
- High drive torque
- Two integrated Hall sensors for measurement of the revolutions and direction of rotation
- Low noise



Technical data

Model	4773.00-0002
Motor	DC motor 18 V
Sensor/Power supply	Hall/5 V DC/0.3 A
Protection class	IP30
Duty cycle idle speed	1 rpm (24 V) 1.5 rpm (32 V)
Rated torque	20% (at 5 min.)
Max. drive torque*	40 Nm
Input	bore hole with keyway

* Load determined for service life of 10,000 double strokes

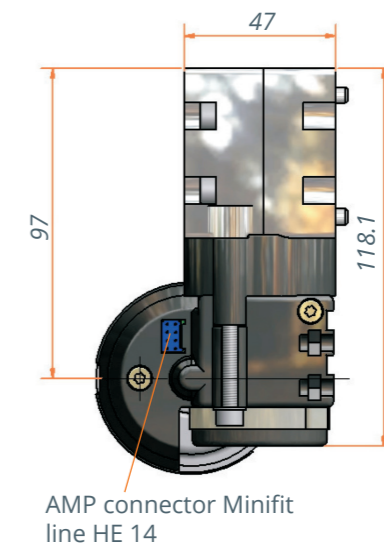
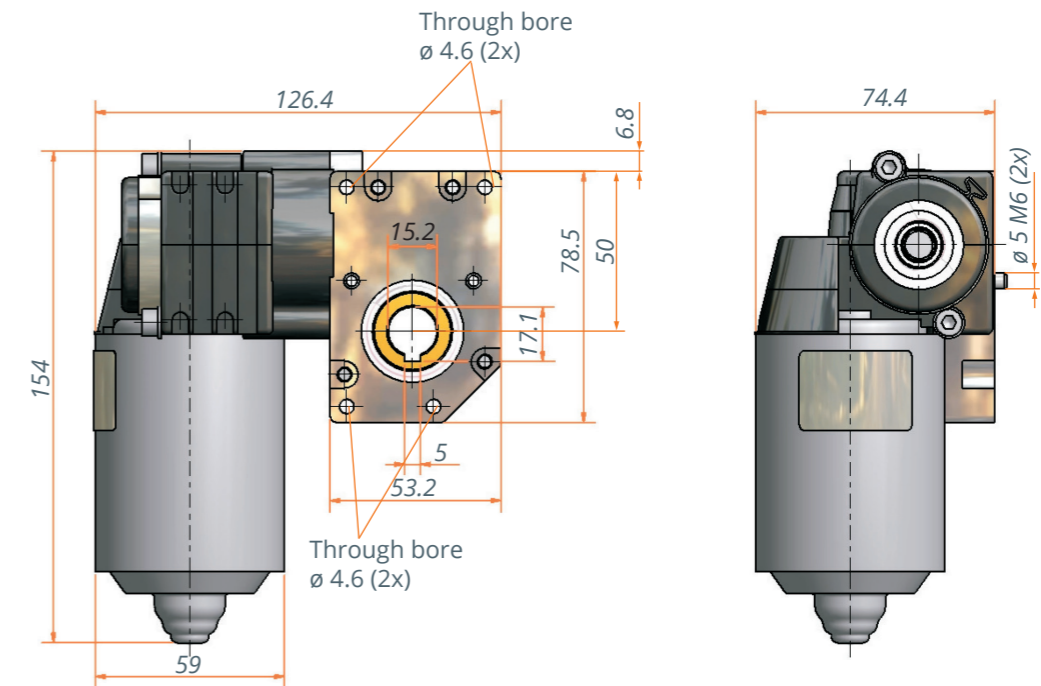

Motor drive for through going spindle 4778

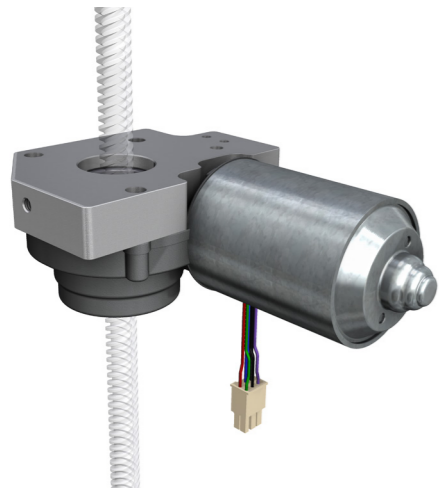

Description

Powerful 24 V DC motor with worm gear, designed for non-rotating through going spindle for pushing and pulling movements. A cable with AMP plug and an integrated Hall sensor allows easy and secure control of the entire system.

Special features

- Two integrated Hall sensors for measurement of the revolutions and direction of rotation
- Different type of internal thread for through going spindles
- Good self-locking properties
- Fast and powerful
- Order spindle separately

Variant key

The variants are formed by different internal thread types for connecting the spindles.

Technical data

Model	4778.00-0002	4778.00-0004	4778.00-0006
Motor	DC motor 24 V	DC motor 24 V	DC motor 24 V
Sensor/Power supply	Hall/5 V DC/0.3 A	Hall/5 V DC/0.3 A	Hall/5 V DC/0.3 A
Protection class	IP30	IP30	IP30
Operating temperature	0° to +30°	0° to +30°	0° to +30°
Electric current (I_N) at max. load	8 A	8 A	8 A
Idle running speed	270 rpm	270 rpm	270 rpm
Duty cycle idle speed	20% (at 5 min.)	20% (at 5 min.)	20% (at 5 min.)
Duty cycle at max. load	10 s ON 240 s OFF	13 s ON 240 s OFF	8 s ON 240 s OFF
Max. lifting force*	1900 N	3700 N	950 N
Traverse speed (constant from F= 0 bis F_{max.})**	24 mm/s	12 mm/s	45 mm/s
Static Self locking ***	200 kg	380 kg	200 kg
Output (Inner thread)	SG16x8P4 RH	Tr16x4 RH	SG14x16P4 RH

* Determined for service life of 10,000 double strokes

** The controller regulates the system in such a way that the travel speed in the entire drive working range is kept as constant as possible

*** In combination with controller, which has a short circuit brake

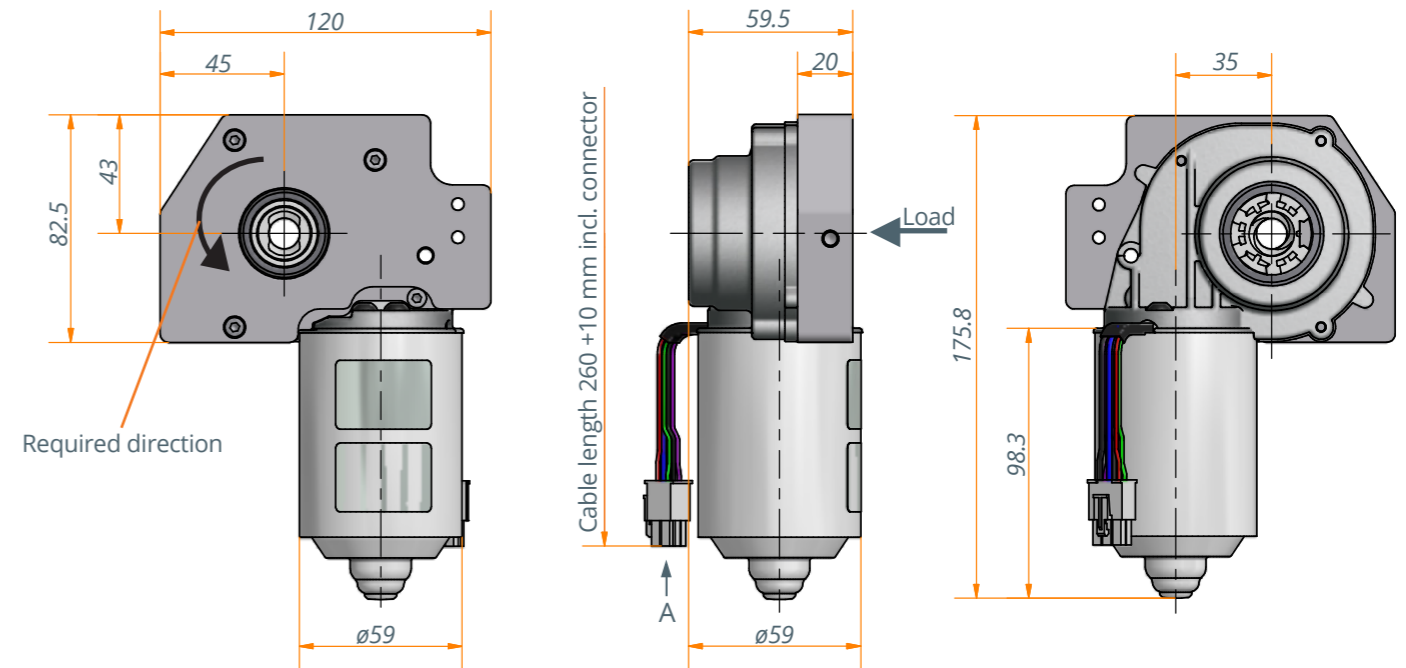

Pin assignment

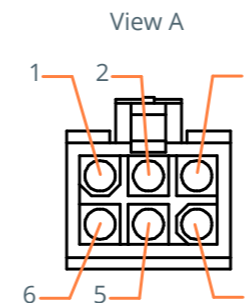

PIN assignment:

- | | |
|---------------------------------|--------------------|
| 1. Motor black - | PIN type AMP170364 |
| 2. Motor blue + | |
| 3. Hall sensor red +5V | PIN type AMP170363 |
| 4. Hall sensor violet, output 2 | |
| 5. Hall sensor black - | |
| 6. Hall sensor green, output 1 | |

Installation position/Mounting

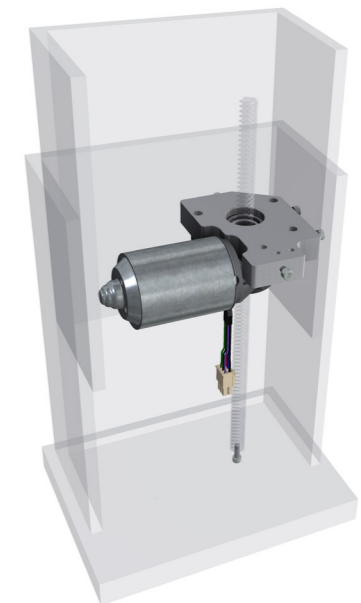

Technical notes

- Spindle is not included; must be ordered separately.
- Achtung: Note correct installation position (see installation example/position).
- The drive must be protected against lateral forces by a guide system.
- The drive working range (nominal torque) is determined for a service life of 10,000 double strokes
- By using a controller with a short-circuit brake the holding torque position of the drive can be increased.

Motor drive for through going spindle 4779



Description

Powerful 24 V DC motor with worm gear, designed for an axis parallel through going spindle. Ideal for integration in a lift column. The drive is only suitable for axial pressure load. A cable with standard connector and integrated Hall sensor technology permit simple and secure control of the entire system.

Special features

- Two integrated Hall sensors for measurement of the revolutions and direction of rotation
- Different type of internal thread for through going spindles
- Good self-locking properties
- Fast and powerful
- Order spindle separately

Variant key

The variants are formed by different internal thread types for connecting the spindles.

Technical data

Model	4779.00-0001	4779.00-0002	4779.00-0003
Motor	DC motor 24 V	DC motor 24 V	DC motor 24 V
Sensor/Power supply	Hall/5 V DC/0.3 A	Hall/5 V DC/0.3 A	Hall/5 V DC/0.3 A
Protection class	IP30	IP30	IP30
Operating temperature	0° to +30°	0° to +30°	0° to +30°
Electric current (I_N) at max. load	6,3 A	7 A	7 A
Idle running speed	133 rpm	133 rpm	133 rpm
Duty cycle idle speed	20% (at 5 min.)	20% (at 5 min.)	20% (at 5 min.)
Duty cycle nominal load*	20 s ON 240 s OFF	33 s ON 240 s OFF	16 s ON 240 s OFF
Max. lifting force	1800 N	2200 N	1500 N
Traverse speed (constant from F= 0 to F_{max}.)	17 mm/s	12 mm/s	24 mm/s
Static Self locking **	180 kg	220 kg	150 kg
Output (Inner thread)	SG12x12P4 RH	Tr16x8P4 RH	SG14x16P4 RH

* Load determined for service life of 10,000 double strokes

** In combination with controller, which has a short circuit brake

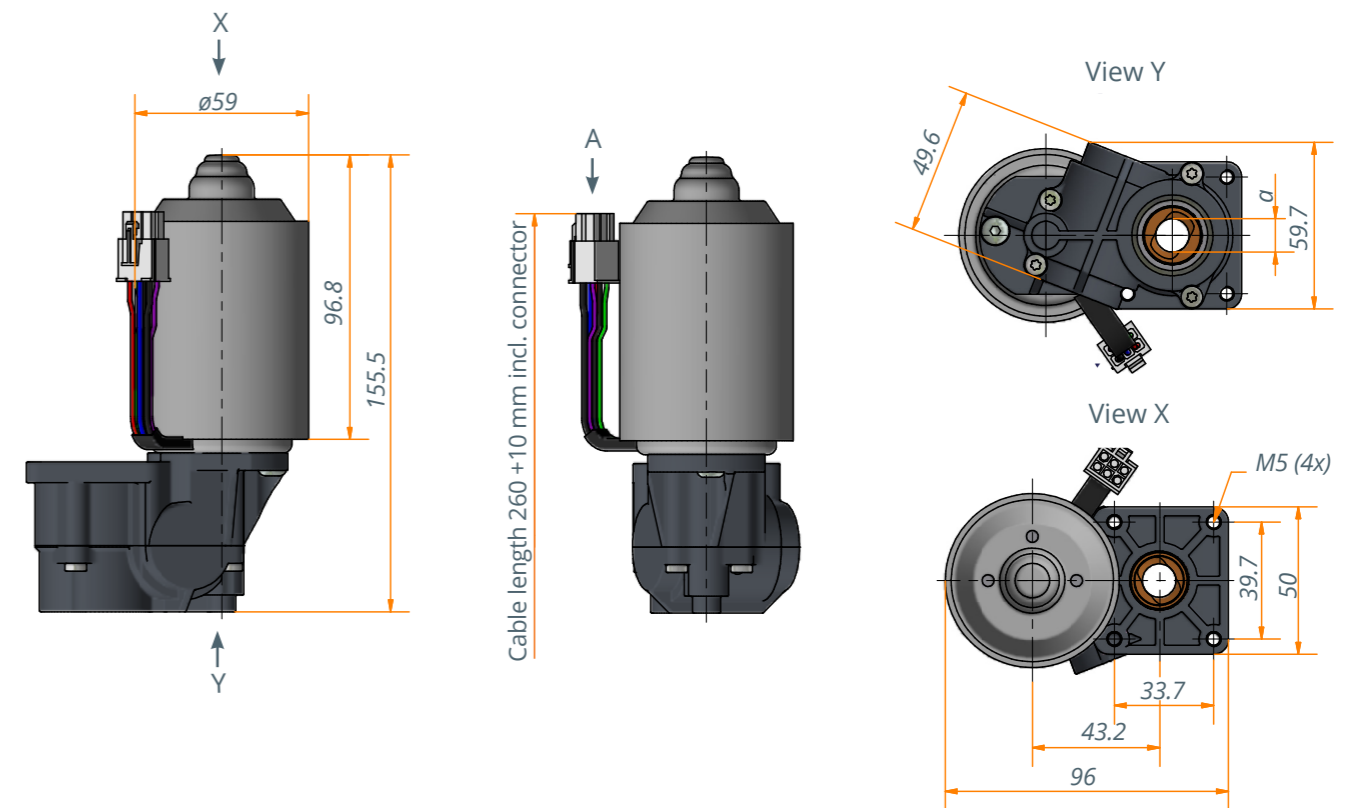

Pin assignment

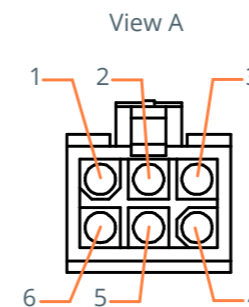

PIN assignment:

- | | |
|---------------------------------|--------------------|
| 1. Motor black - | PIN type AMP170364 |
| 2. Motor blue + | |
| 3. Hall sensor red +5V | PIN type AMP170363 |
| 4. Hall sensor violet, output 2 | |
| 5. Hall sensor black - | |
| 6. Hall sensor green, output 1 | |

Installation position/Mounting

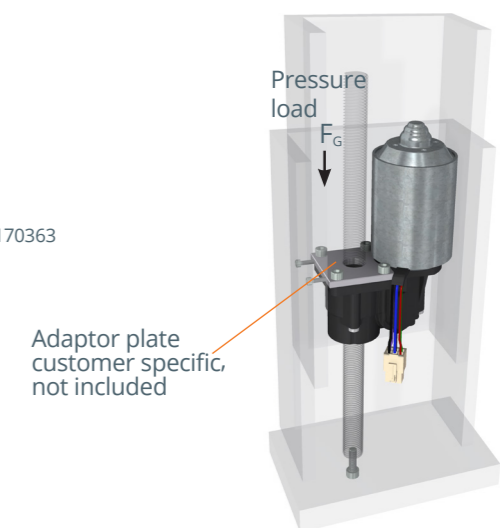

Technical notes

- Spindle not included; must be ordered separately.
- Attention: The drive is only suitable for axial pressure load. Note correct installation position (see installation example).
- The drive must be protected against lateral forces by a guide system.
- The drive working range (nominal torque) is determined for a service life of 10,000 double strokes.
- By using a controller with a short-circuit brake the holding torque position of the drive can be increased.
- The controller* regulates the system in such a way that the travel speed in the entire drive working range is kept as constant as possible.

* In combination with LogicData control box Compact-3

Inline spindle drive 3120



Description

Motorized solution for the individual sit-stand workplace. Stepless height adjustment to customer specific stroke.
A slender design allows to integrate the complete inline actuator into the tube of a table leg.

Special features

- Simple mounting
- Integrated position measuring system
- Single telescopic function
- Various spindle lengths and different spindle pitches are possible



Technical data

Model	3120.00-V01EXXXHXXX	3120.00-V02EXXXHXXX
Motor	DC Motor 24 V	DC Motor 24 V
Sensor/Power supply	Hall/5 V DC/0.3 A	Hall/5 V DC/0.3 A
Protection class	IP30	IP30
Duty cycle	20% (at 5 min.)	20% (at 5 min.)
Idle running speed	100 rpm (24 V) 150 rpm *	100 rpm (24 V) 150 rpm *
Max. stroke	Retracted length -111 mm	Retracted length -109 mm
Type of spindle	SG14x16P4 RH **	SG14x16P4 RH **
Max. lifting force	800 N	800 N
Max. drive torque	3 Nm	3 Nm
Movement speed	43 mm/s	43 mm/s

* In combination with LogicData control box Compact-3

** Further types of spindles on request

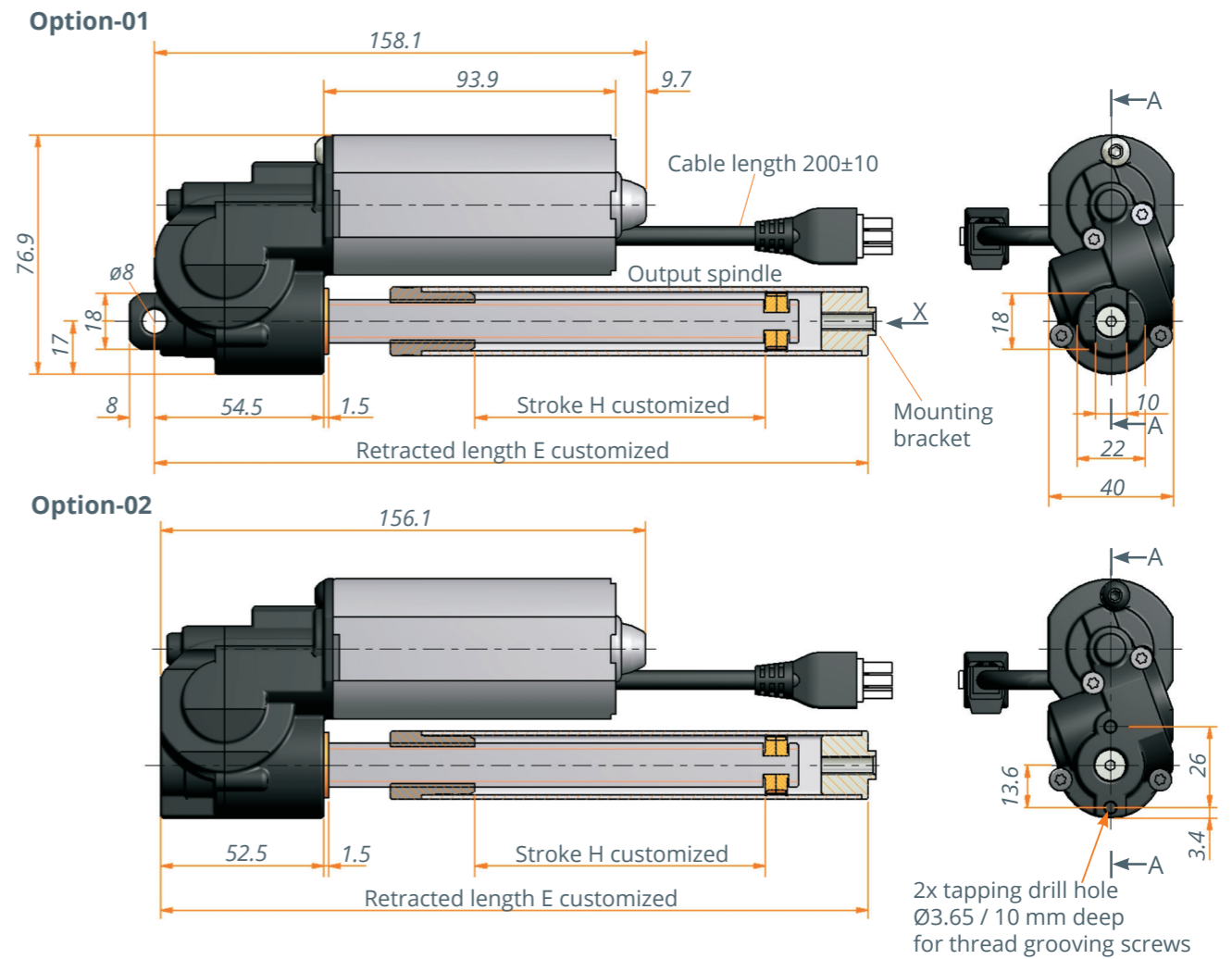

Technical notes

- Depending on the the spindle pitch, the system could back-drive.

Inline spindle drive 3122

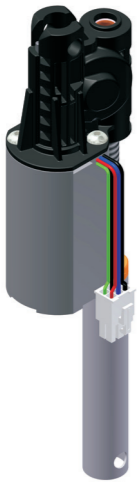

Description

Motorized solution for the individual sit-stand workplace. Stepless height adjustment to customer specific stroke.
A slender design allows to integrate the complete inline actuator into the tube of a table leg.

Special features

- Simple mounting
- Integrated position measuring system
- Single telescopic function
- Various spindle lengths and different spindle pitches are possible



Technical data

Model	3120.00-V01EXXXHXXX
Motor	DC Motor 24 V
Sensor/Power supply	Hall/5 V DC/0.3 A
Protection class	IP30
Duty cycle	20% (at 5 min.)
Idle running speed	180 rpm (24 V) 180 rpm *
Max. stroke	Retracted length -171 mm
Type of spindle	SG12x16P4 RH **
Max. lifting force	600 N
Max. drive torque	2.5 Nm
Movement speed	48 mm/s

* In combination with LogicData control box Compact-3

** Further types of spindles on request

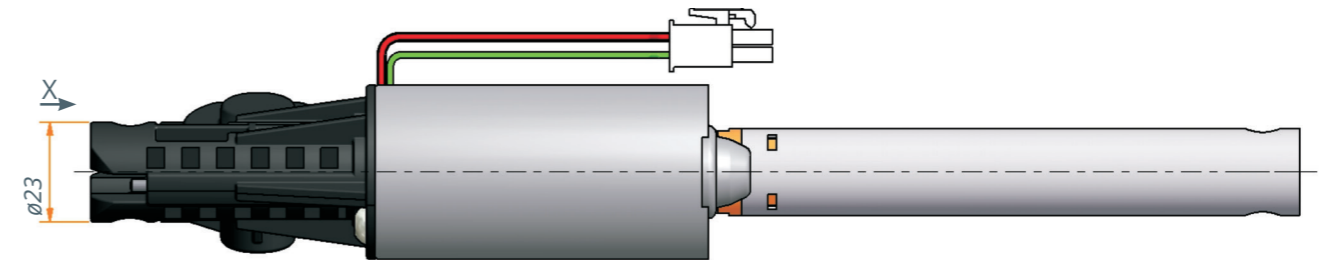
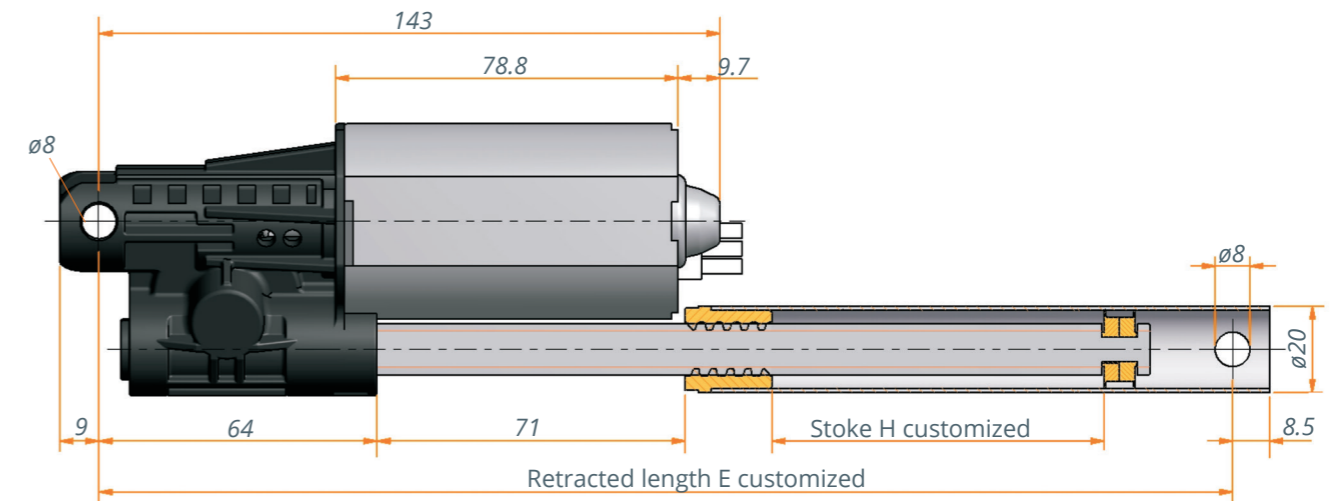

Technical notes

- Depending on the the spindle pitch, the system could back-drive

View X

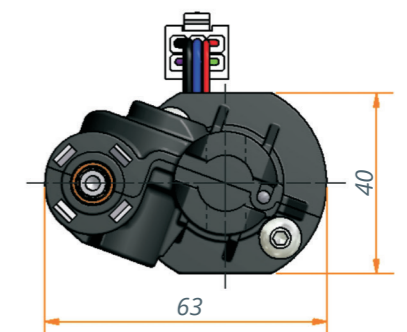

Drive with throughgoing spindle 3146

Description

Direct current motor with worm gear and through-going not rotating spindle for push and pull movements.

Special features

- Integrated position measuring system
- Spindle pitch can be modified to customer requirements



Technical data

Model	3146
Motor	DC Motor 18 V
Sensor/Power supply	Hall/5 V DC/0.3 A
Protection class	IP30
Duty cycle	20% (at 5 min.)
Idle running speed	90 rpm (24 V) 130 rpm *
Type of spindle	Tr12x3 RH
Max. drive torque	1200 N
Movement speed	4 mm/s

* In combination with LogicData control box Compact-3

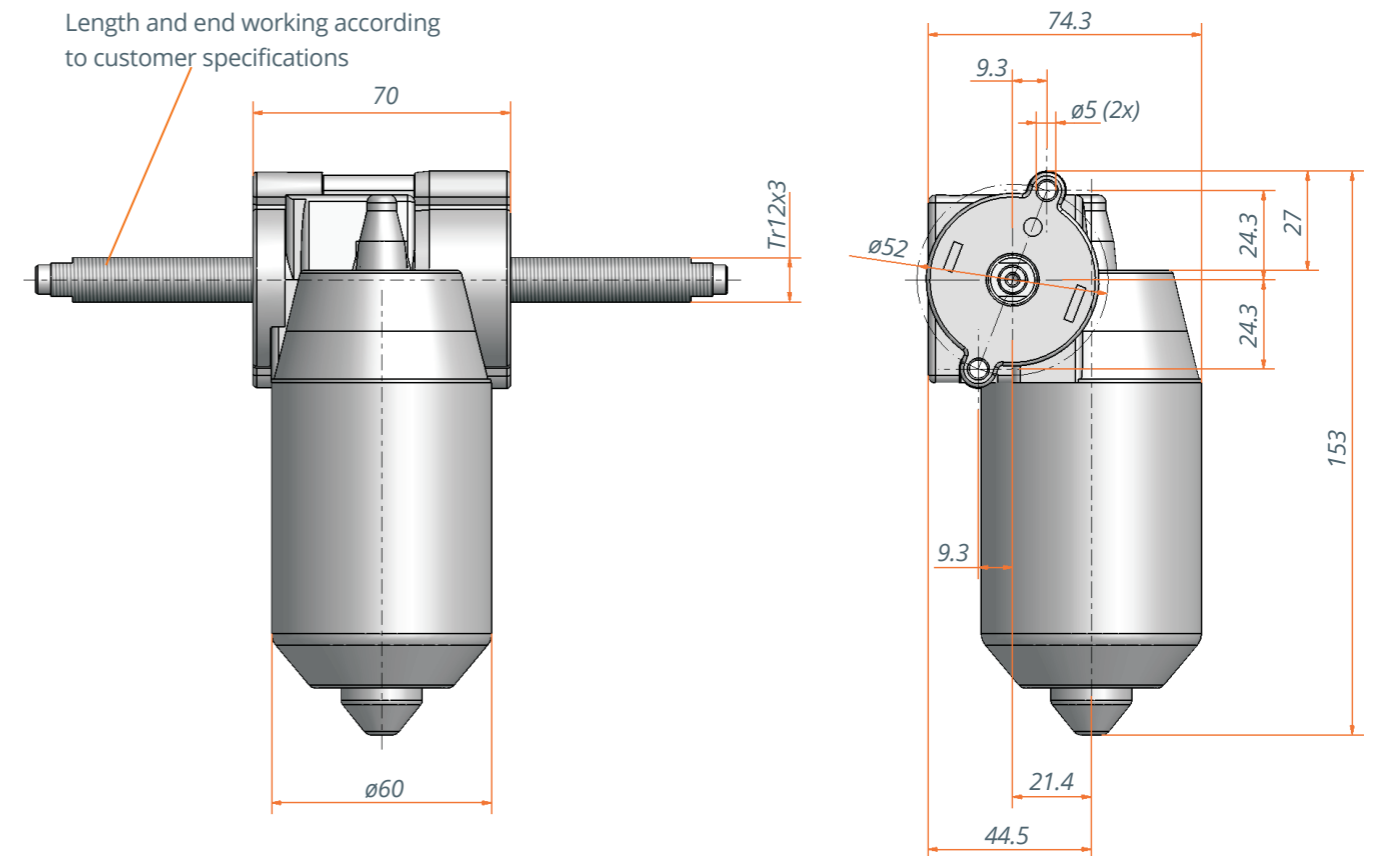

Technical notes

- Depending on the the spindle pitch, the system could back-drive.

Electric drive with synchronous telescopic spindle 4114

Description

Electric motor solution for the individual sit-stand workplace. Smooth running stepless height adjustment.

Special features

- Simple mounting
- Integrated position measuring system
- Twice telescopable
- Electronic synchronisation with up to 24 actuators
- Synchronous movement of the spindle units, double stroke speed

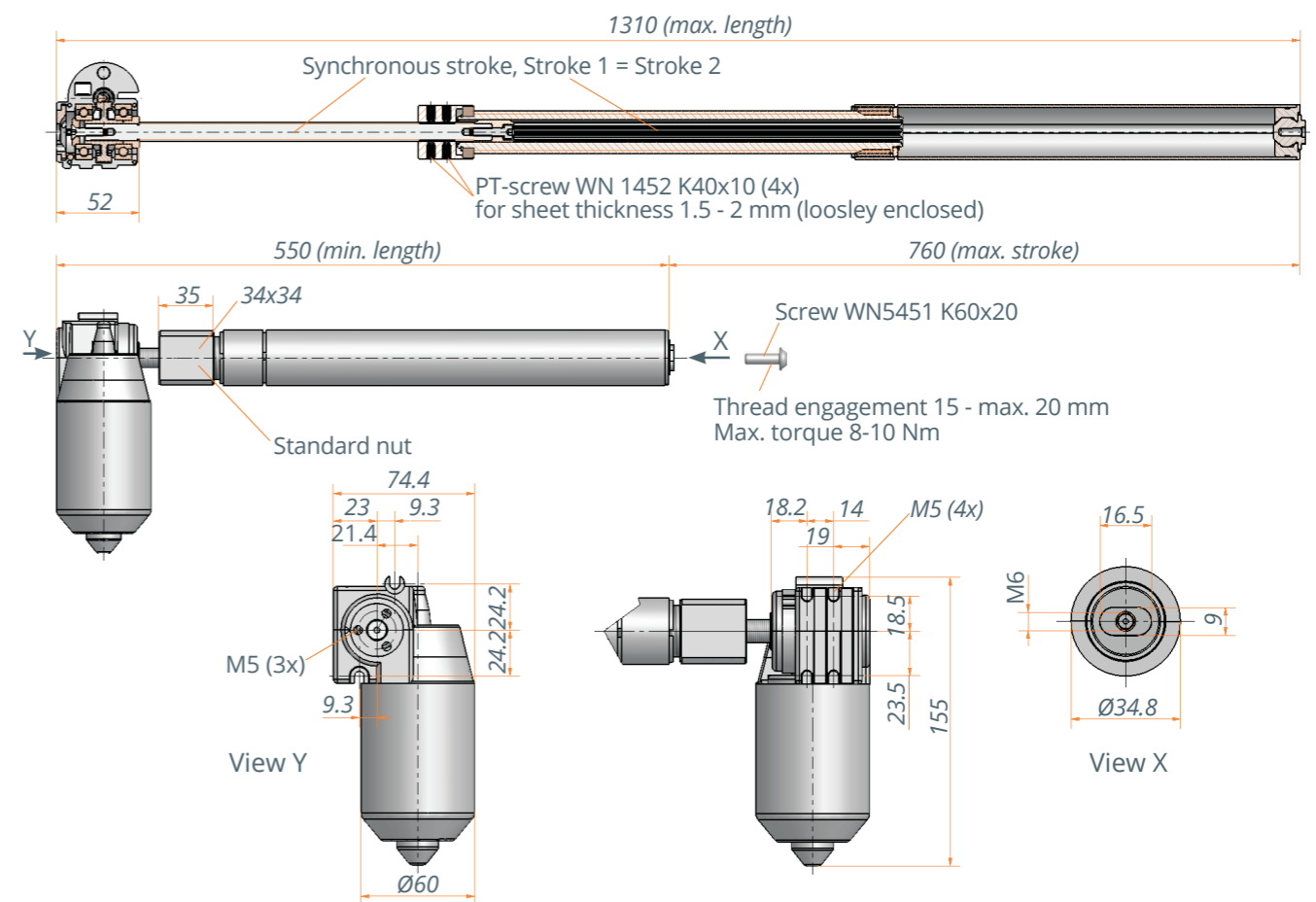

Technical data

Model	4114
Motor	DC Motor 24 V
Sensor/Power supply	Hall/5 V DC/0.3 A
Protection class	IP30
Duty cycle	20% (at 5 min.)
Idle running speed	100 rpm (24 V) 150 rpm*
Max. stroke	Retracted length -170 mm x2
Type of spindle	SG25x12P6 RH**, SG12x12P4 RH
Max. lifting force	800 N
Max. drive torque	5 Nm
Movement speed	50 mm/s*

* In combination with LogicData control box Compact-3

** Further types of spindles on request

Technical notes

- Depending on the the spindle pitch, the system could back-drive.

Application example

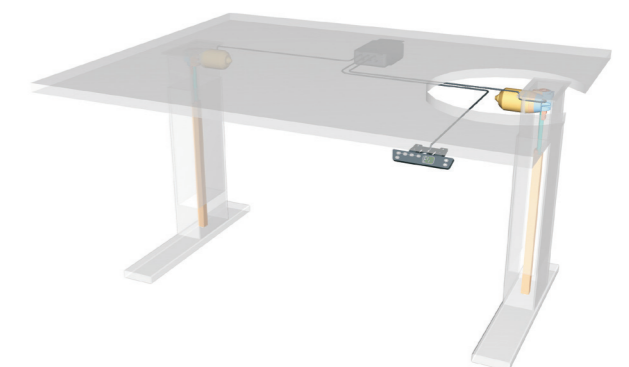

Ways of installation

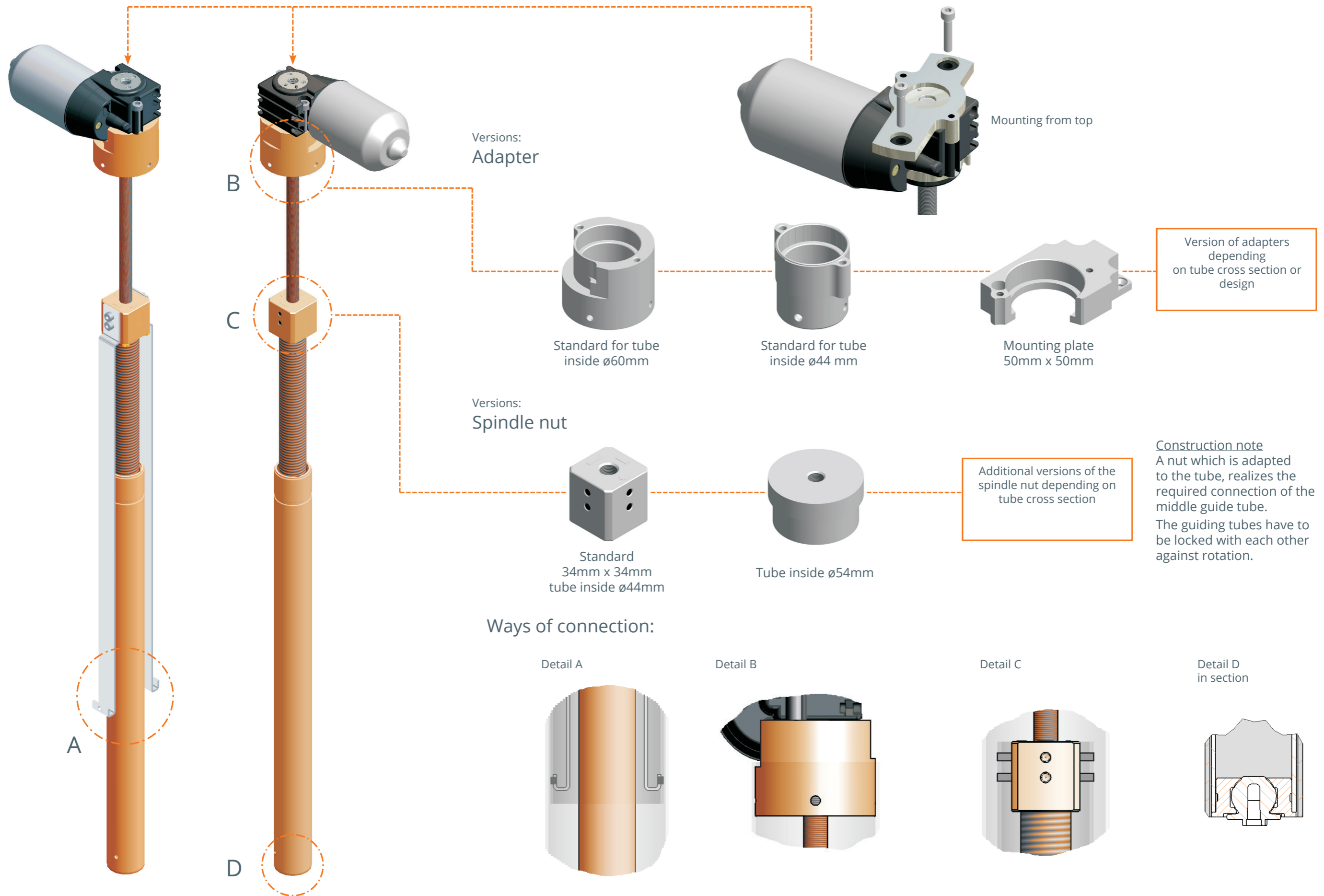

Electric spindle drive 4640

Description

Motorized solution for sit-stand workplace. Stepless height adjustment to customer specific travel distance.

Special features

- Simple mounting
- Integrated position measuring system
- Single telescopic function
- Synchronisation with up to 26 actuators
- Various spindle lengths and different spindle pitches are possible

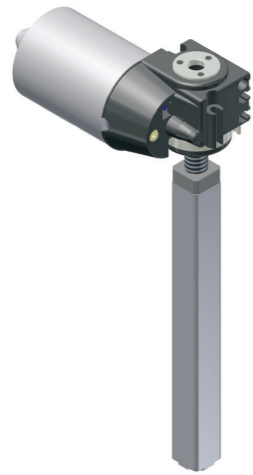

Technical data

Model	4640.00-V01EXXXHXXX
Motor	DC Motor 24 V
Sensor/Power supply	Hall/5 V DC/0.3 A
Protection class	IP30
Duty cycle	20% (at 5 min.)
Idle running speed	100 rpm (24 V) 150 rpm *
Max. stroke	Retracted length -107 mm
Type of spindle	SG14x16P4 RH **
Max. lifting force	800 N
Max. drive torque	5 Nm
Movement speed	40 mm/s

* In combination with LogicData control box Compact-3

** Further types of spindles on request

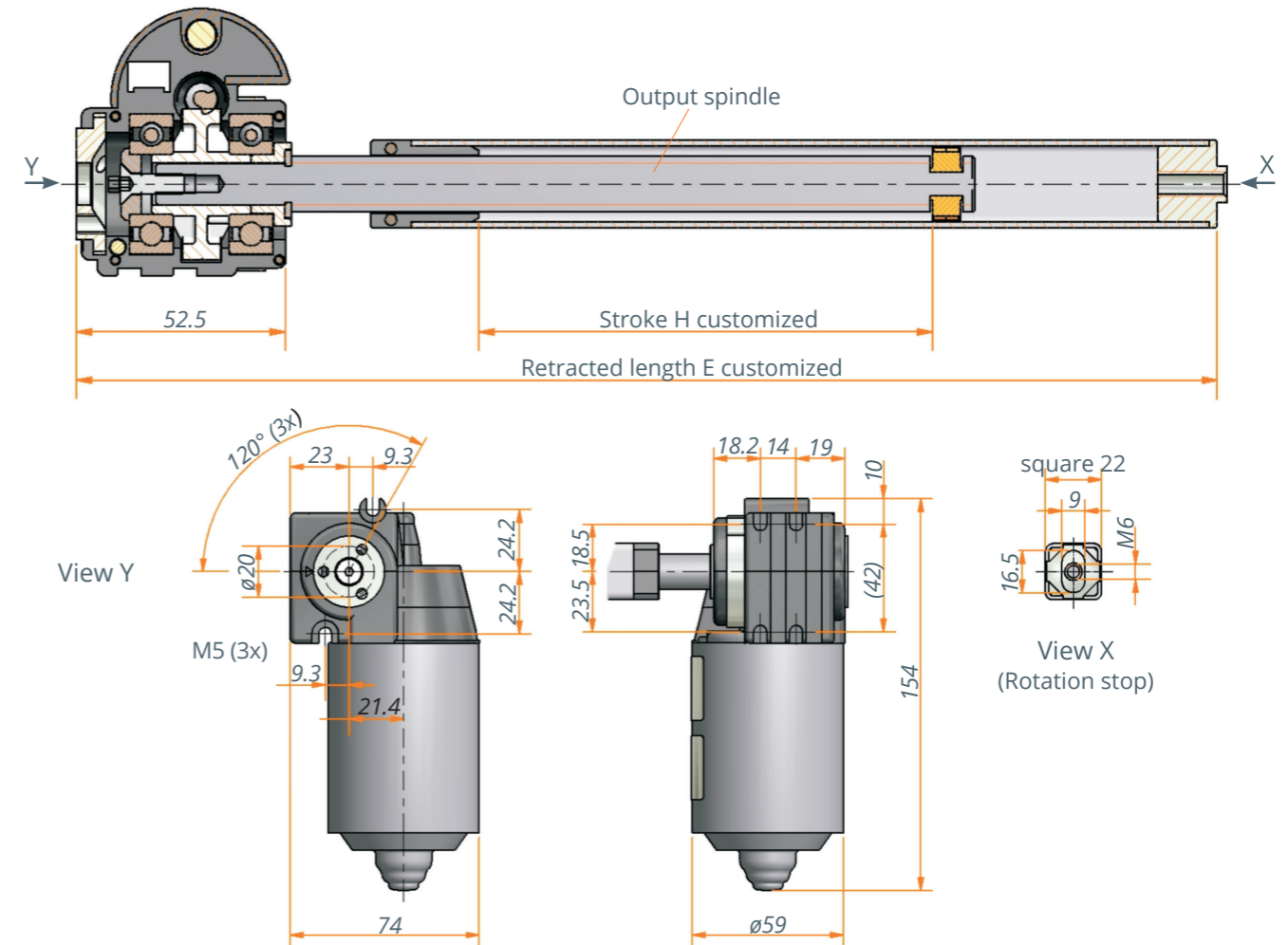

Technical notes

- Depending on the the spindle pitch, the system could back-drive.

Application example

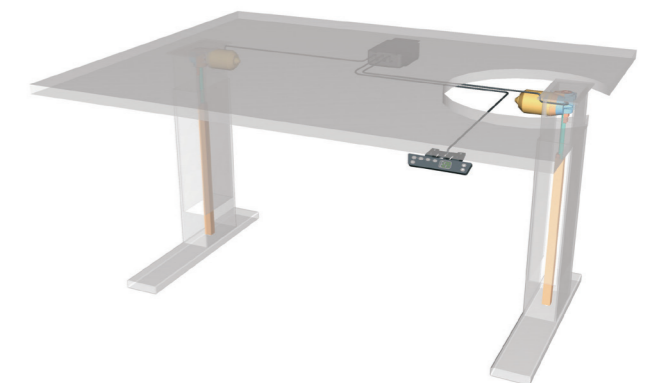

Electric spindle drive 4642

Description

Motorized solution for sit-stand workplaces. Stepless height adjustment to customer specific travel distance.

Special features

- Simple mounting
- Integrated position measuring system
- Single telescopic function
- Synchronization with up multiple actuators
- Two spindle pitches are available
- Installation length and stroke are customizable



Technical data

Model	4642.00-V01EXXXHXXX	4642.00-V02EXXXHXXX
Motor	DC Motor 18 V	DC Motor 18 V
Sensor/Power supply	Hall/5 V DC/0.3 A	Hall/5 V DC/0.3 A
Protection class	IP30	IP30
Duty cycle	20% (at 5 min.)	20% (at 5 min.)
Idle running speed	100 rpm (24 V), 150 rpm *	100 rpm (24 V), 150 rpm *
Max. stroke	Retracted length -135 mm	Retracted length -135 mm
Type of spindle	Tr16x8P4 RH**	SG14x16P4 RH **
Max. lifting force	1500 N	800 N
Max. drive torque	5 Nm	5 Nm
Movement speed	20 mm/s	40 mm/s

* In combination with LogicData control box Compact-3

** Further types of spindles on request

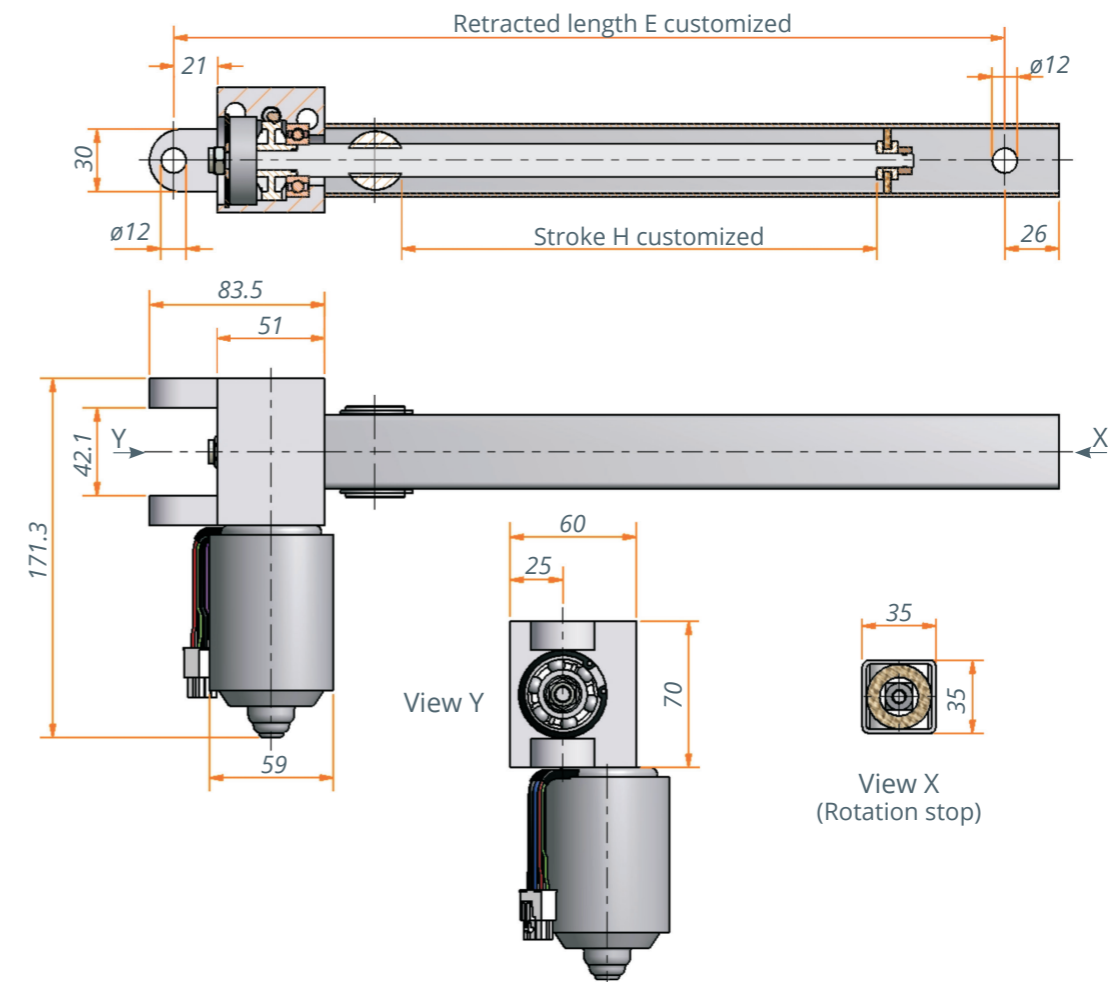

Technical notes

- Depending on the the spindle pitch, the system could back-drive.

Electric spindle drive 4643

Description

Powerful motorized drive unit with push-pull spindle and electromechanical end-switches. Stroke to customer demands. By simplified control function, an additional distance measuring system is not required.

Special features

- Very powerful
- For very high holding torques
- Simple installation
- Two electromechanical end-switches
- Can be adapted easily by fork crown and mounting adapter flange

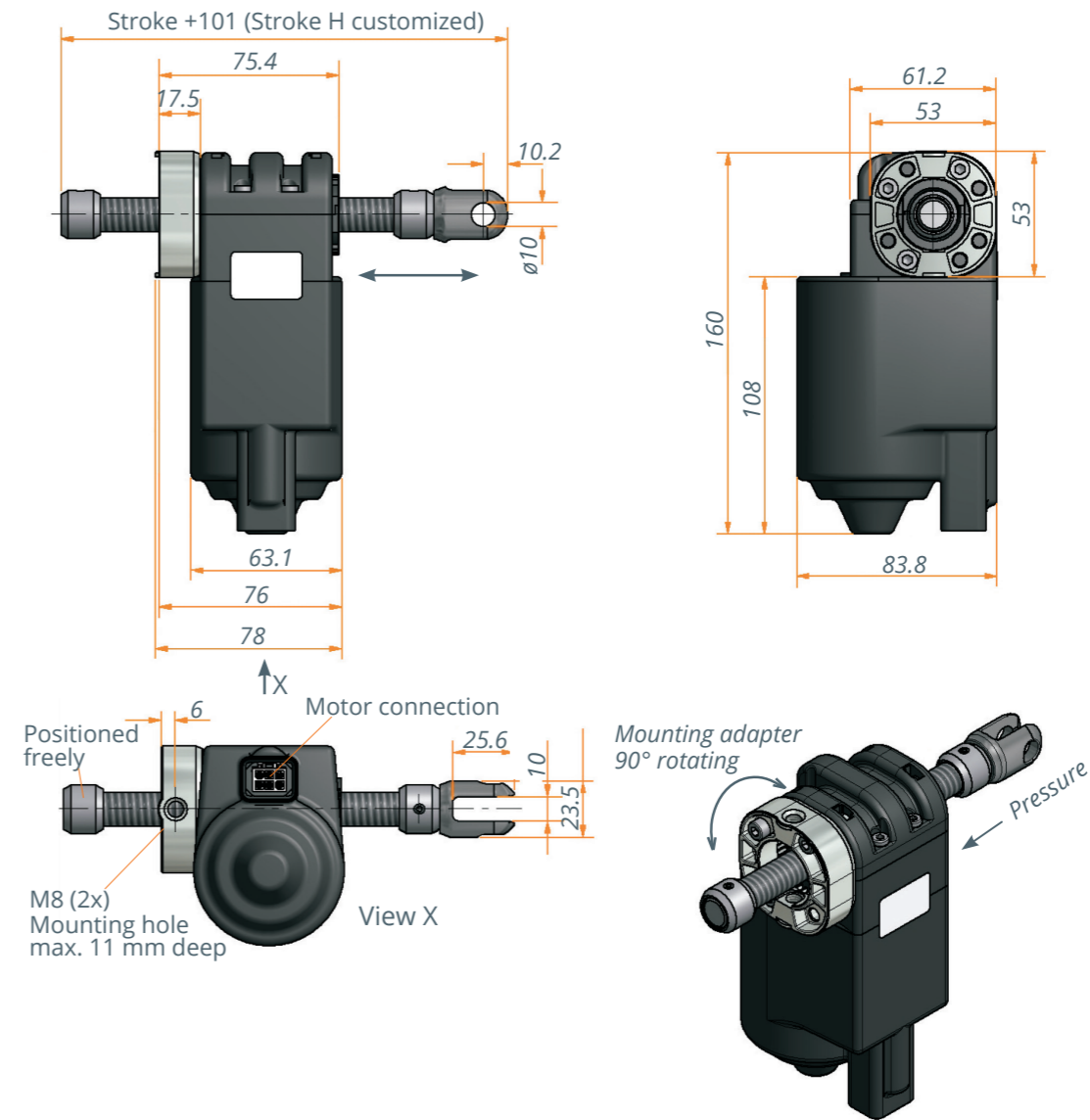

Technical data

Model	4640.00-V01EXXXHXXX
Motor	DC Motor 18 V
Sensor/Powerd supply	Hall/5 V DC/0.3 A
Protection class	IP30
Duty cycle	20% (at 5 min.)
Type of spindle	Tr14x3 RH
Max. pressure force	3000 N
Movement speed	4 mm/s*

* In combination with LogicData control box Compact-3

** Further types of spindles on request

Technical notes

- Depending on the the spindle pitch, the system could back-drive.

Control box Compact



Description

Compact is the control unit for high adjustable workstations and is matched to all Ketterer drives.

With one control unit can be controlled:

- up to three drives in parallel structure (one or two drives follow the master drive)
- two drives synchronously (drives are individually controlled)

Special features

- Control box Compact^{eco}, Firmware-Version 1.9
- Voltage supply variants: 230 V and 110 V
- Freely stroke with hand switch with display (HSU-MDF-4M2-LD or TOUCHfx) programmable
- Ketterer can preprogram a desired stroke
- Duty cycle 2 min. ON/ 18 min. OFF

Technical data



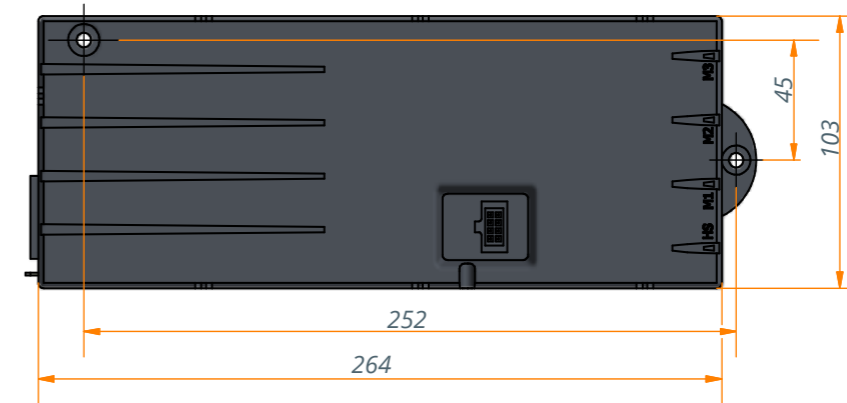

Control box	Description	Drives for use with
1000.49-36 / Compact-e-3-KTS-4778-EU	one to three motors parallel	(4778, 4779)**
1000.49-46 / Compact-e-3-KTS-4778-US	one to three motors parallel	
1000.49-37 / Compact-e-3-KTS-4779-EU	one to three motors parallel	
1000.49-47 / Compact-e-3-KTS-4779-US	one to three motors parallel	(3143, 4114, 4630, 4701, 4773) *
1000.49-01 / Compact-e-3-KTS-4630-EU	one to three motors parallel	
1000.49-02 / Compact-e-3-2-KTT-4630-EU	two motors synchronous	
1000.49-11 / Compact-e-3-KTS-4630-US	one to three motors parallel	4643 **
1000.49-12 / Compact-e-3-2-KTT-4630-US	two motors synchronous	
1000.49-03 / Compact-e-3-KTS-3130-EU	one to three motors parallel	(3120, 3121, 3130, 3131)**
1000.49-04 / Compact-e-3-2-KTT-3130-EU	two motors synchronous	
1000.49-13 / Compact-e-3-KTS-3130-US	one to three motors parallel	
1000.49-14 / Compact-e-3-2-KTT-3130-US	two motors synchronous	3122 **
1000.49-05 / Compact-e-3-KTS-3122-EU	one to three motors parallel	
1000.49-06 / Compact-e-3-2-KTT-3122-EU	two motors synchronous	
1000.49-15 / Compact-e-3-KTS-3122-US	one to three motors parallel	3133.00 **
1000.49-09 / Compact-e-3-KTS-3133.00-EU	one to three motors parallel	
1000.49-10 / Compact-e-3-2-KTT-3133.00-EU	two motors synchronous	
1000.49-19 / Compact-e-3-KTS-3133.00-US	one to three motors parallel	3133.48 **
1000.49-20 / Compact-e-3-2-KTT-3133.00-US	two motors synchronous	
1000.49-07 / Compact-e-3-KTS-3133.48-EU	one to three motors parallel	3133.48 **
1000.49-08 / Compact-e-3-2-KTT-3133.48-EU	two motors synchronous	
1000.49-17 / Compact-e-3-KTS-3133.48-US	one to three motors parallel	
1000.49-18 / Compact-e-3-2-KTT-3133.48-US	two motors synchronous	

* Motor cable 4138.53-01/ Length 1 m or 4138.53-02/ Length 2 m

** Motor cable 3122.53-02/ Length 1.75 m



further details under www.logicdata.at

Power cable	Connector
3143.53-22 / Power cable LOG-CBL-PWK	plug for control with 3-pin Schuko - Europe 
3143.53-23 / Power cable LOG-CBL-PWK-UK	for control with 3-pin plug - UK 
3143.53-24 / Power cable LOG-CBL-PWK-DK	for control with 3-pin plug - Denmark 
3143.53-25 / Power cable LOG-CBL-PWK-SW	for control with 3-pin plug - Schweiz 
3143.53-28 / Power cable LOG-CBL-PWK-USA	for control with 3-pin plug - USA 

Technical notes

- Power cable has to be ordered separately.
- For stroke programming or changing on site a hand switch with display is always required (see hand control and motor cables).
- Please note the permissible duty cycle of the controller. If the operating times are exceeded the controller switches off automatically.
- Attention: Electric drives usually have a shorter duty cycle than controllers and are thus system-leading.

Hand control and motor cables



Description







Ketterer's range of accessories offers a large selection of hand switches in various designs, with or without display, with simple or touch buttons and various motor cables to suit the respective Ketterer drives.

Special features

- Stepless adjustment
- User-defined and application-oriented control of your stepless adjustment
- Can be used with the Compact controller and all Ketterer motor drives

Technical data

Motor cable	For use with drives
4138.53-01/ Length 1 m 4138.53-02/ Length 2 m	3143, 4114, 4630, 4701, 4773
3122.53-02/ Length 1,75 m	4643, 3120, 3121, 3131, 3122, 3133.00, 3133.48

Hand switch	Description
3143.47-05/ HSU-MDF-4M2-LD	Switch with display and four memory positions, stroke heights and two up-down buttons, free programmable 
3143.47-43/ TOUCH fx	Switch with display and four memory positions, with touch & click function 
3143.47-30/ HSM-OD-2-LD	Simple hand control, up-down 
3143.47-42/ TOUCH-basic-DN	Simple hand control up-down, with touch function 
3143.47-08/ IRR-DSK-SET-LIGHT	IR remote control consisting of, IR receiver, remote control (including battery) and manual 
3143.47-0001/ Receiver, remote control	RF remote control consisting of RF receiver, remote control (including battery), and manual 

* Further details under <http://www.logicdata.at>

Motor cable 4138.53-01: 1 m long
4138.53-02: 2 m long

AMP - Serie HE 14 plug allocation

A			B					
1	3	5	7	4	5	6	7	8
2	4	6	8	1	2	3	4	5

Pin-No.	signal	colour	Pin-No.	signal	colour
6,8	motor blue	black, blue	4	motor blue	black, blue
5,7	motor red	brown, orange	8	motor red	brown, orange
2	+5VDC, reverb	red	2	+5VDC, reverb	red
4	GND, reverb	grey	3,7	reverb-signal 2	grey
3	reverb-signal 2	green	5	GND, reverb	green
1	reverb-signal 1	violet	1	reverb-signal 1	violet

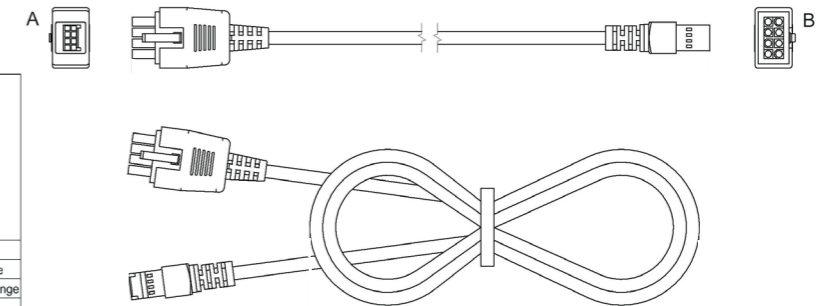

Motor cable 3122.53-02: 1.75 m long

AMP - 172160 plug allocation

A			B					
1	4	5	6	4	5	6	7	8
2	3	6	8	1	2	3	4	5

Pin-No.	signal	colour	Pin-No.	signal	colour
1	motor blue	black, blue	4	motor blue	black, blue
2	motor red	brown, orange	8	motor red	brown, orange
3	+5VDC, reverb	red	2	+5VDC, reverb	red
4	reverb-signal 2	green	5	reverb-signal 2	green
5	GND, reverb	gray	3,7	GND, reverb	gray
6	reverb-signal 1	violet	1	reverb-signal 1	violet

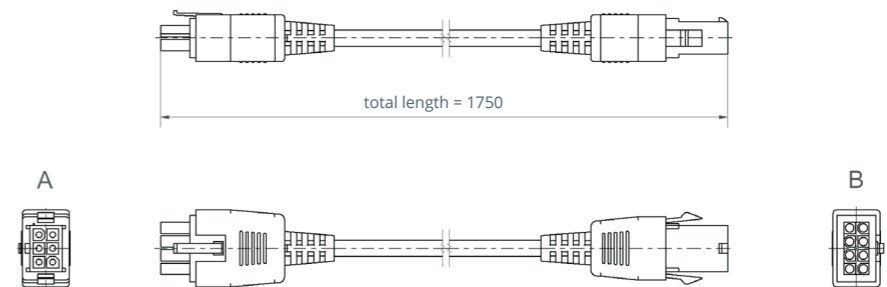

Technical notes

- Hand switches with touch function require the Compact controller with firmware Version 1.9
- For stroke programming or changing the travel on site a hand switch with display is always required

Profile tubes - Profile rods

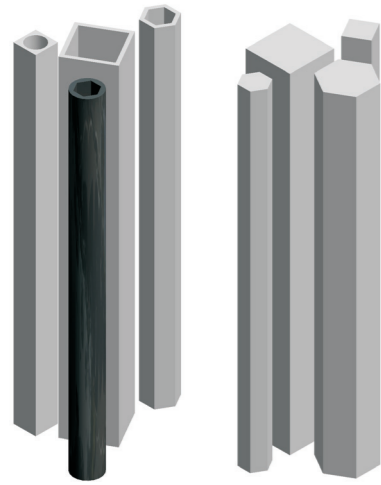

Description

You get profile rods and profile tubes as rods in a length of 3 m.

Special features

- Profile rods are made of steel and drawn according to DIN 176 (hexagon bars)
- Profile rods are made of steel and drawn according to DIN 178 (square bars)
- Profile tubes are made of steel and drawing to DIN 2391
- Further profile rods, profile tubes, special lengths and machining on request

Profile tubes drawn according to DIN 2391

Item number Steel version	Item number Brass version	Item number Aluminium black (anodised) Aluminium-tube DIN 17611 / quality E6	Outer dimension	Inner dimension
209R0.08.0-6kt5	-	-	Ø8	hex 5 mm
209R0.09.0-6kt6-SL	-	-	Ø9	hex 6 mm
209R0.10.0-6kt6	-	-	Ø10	hex 6 mm
209R0.10.0-6kt7	-	-	Ø10	hex 7 mm
209R0.12.0-4kt7	203R0.12.0-4kt7	-	Ø12	square 7 mm
-	203R0.12.0-4kt8	-	Ø12	square 8 mm
209R0.12.0-6kt6	-	201R0.12.0-6kt6SL	Ø12	hex 6 mm
-	-	201R0.12.0-6kt7	Ø12	hex 7 mm
-	-	201R0.12.0-6kt8	Ø12	hex 8 mm
209R6.09.0-6kt6	-	-	hex 9 mm	hex 6 mm
209R6.12.0-6kt9	-	-	hex 12 mm	hex 9 mm

Profile rods drawn according to DIN 176 (hexagon bars) and according to DIN 178 (square bars)

Item number Steel version	Item number Brass version	Outer dimension
209S4.06.0	203V4.06.0	square 6mm
209S6.05.0		hex 5 mm
209S6.06.0		hex 6 mm
209S6.07.0		hex 7 mm
209S6.08.0	203V6.08.0	hex 8 mm
209S6.09.0		hex 9 mm
209S6.12.0	203V6.12.0	hex 12 mm

B. Ketterer Söhne GmbH & Co. KG
Bahnhofstrasse 20
78120 Furtwangen
Germany

Phone: +49 7723 9323-0
Mail: info@ketterer.de
Web: www.ketterer.de

© Ketterer Drives, 05.06.2019