

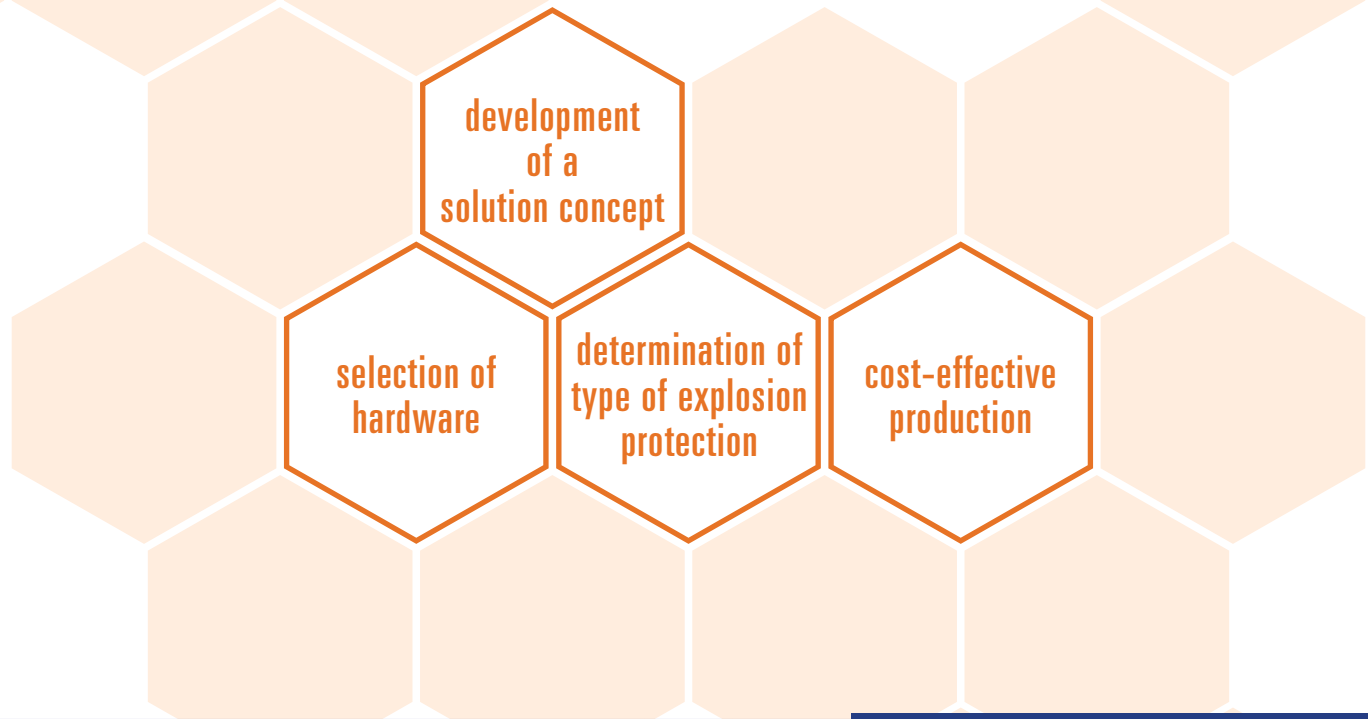

**together**

**we invent the solution**





# form follows function



## Users

- > oil and gas industry
- > petrochemistry
- > chemical industry
- > pharmaceutical industry
- > food, beverages and tobacco industry
- > shipbuilding and offshore industry
- > wood processing

## Range of services

- > advisory service
- > electrical planning
- > mechanical construction
- > ensuring of explosion protection
- > documentation
- > certification
- > software engineering
- > programming
- > production
- > quality assurance
- > works acceptance
- > commissioning support
- > after sales service

Too many compromises are made to the function of a system due to the mechanical design. Causing not only expensive but also inefficient designs. Therefore, a critical electrical control system needs to be engineered where it will ideally function, the design will then follow the function. This requires early involvement. Let us together invent the solution.





customer-oriented excellence in ex process-oriented transparent result-oriented comprehensible quality-oriented communication-oriented customer-oriented excellence in ex process-oriented transparent result-oriented comprehensible quality-oriented communication-oriented customer-oriented excellence in ex process-oriented transparent result-oriented comprehensible quality-oriented communication-oriented customer-oriented excellence in ex process-oriented transparent result-oriented comprehensible quality-oriented communication-oriented

# “We have a common goal – maximum safety and the best possible system solutions.”

Machines and installations for hazardous areas are naturally subject to the strictest safety conditions. R. STAHL as one of the world’s leading manufacturers of explosion-protected components offers long-standing experience and extensive know-how and helps you to fulfil the standards that are often very specific. Our knowledge and our support exceed our own product portfolio and also contain the organization of many services from other fields. Because your safety is our profession.

- > more than 3,000 certificates for explosion protection
- > more than 70 active patents
- > member in numerous standardization committees, technical committees and working committees

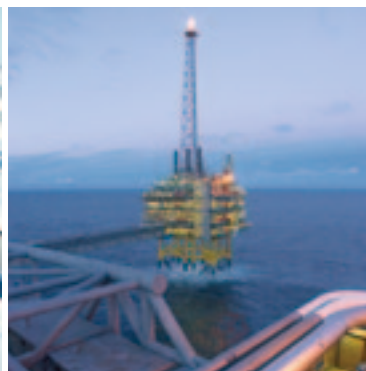



# early involvement

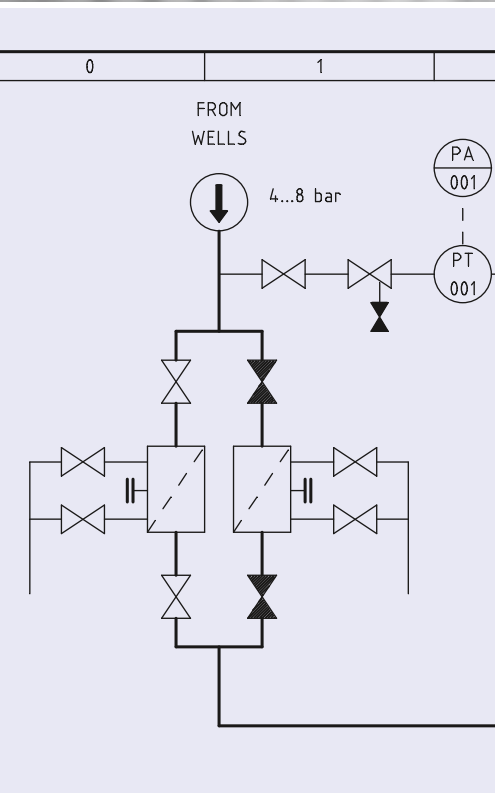

Skid conduit installation



Smart monitor for visualization wire-line







# oil & gas

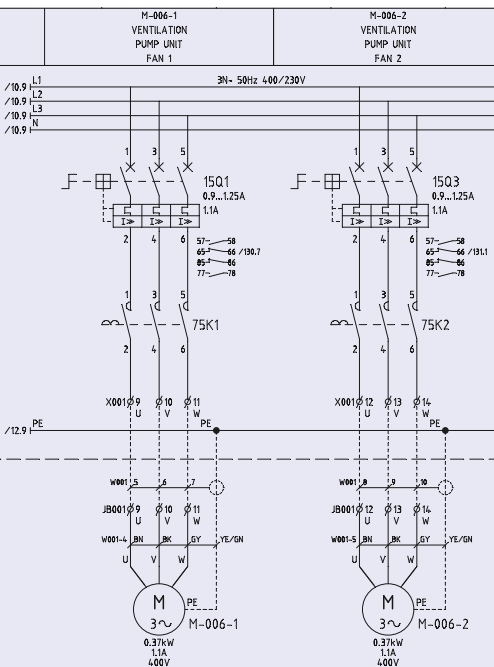

Shelter for Process  
Gas-H2 Analyzer



Ex de operator control  
panel (CUBEx series 8264)  
with PLC





off shore drilling and exploration on shore drilling and exploration off shore recovery on shore recovery transportation refinery facility and logistics  
 facility and logistics off shore drilling and exploration on shore drilling and exploration off shore recovery on shore recovery transportation refinery facility and logistics  
 recovery on shore recovery transportation refinery facility and logistics off shore drilling and exploration on shore drilling and exploration off shore recovery on shore recovery transportation

# “We want satisfied and successful customers.”

The oil and gas industry changes all the time and constantly has to face new challenges in regard to performance rate and productivity. Knowledge becomes more specific, systems have to become more and more resistant. We offer our extensive specialist knowledge and experience in finding solutions for difficult problems. Be it burning heat, freezing cold, salty sea water or rough sandstorms – R.STAHL products are used all over the world under extreme environmental conditions. We understand your process and thus your requirements.

- > extended temperature range
  - 20 °C ... +40 °C
  - 50 °C ... +55 °C
- > saltwater-resistant
- > 100% quality controlled in our own test laboratory

Control panel with STAHL series 8010/8082 signal lights and pushbuttons



Containerized control building for Root Compressor including power transformers



Containerized Low Voltage MCC, control panel and electrical heater thyristor panels





# chemistry & pharmaceuticals

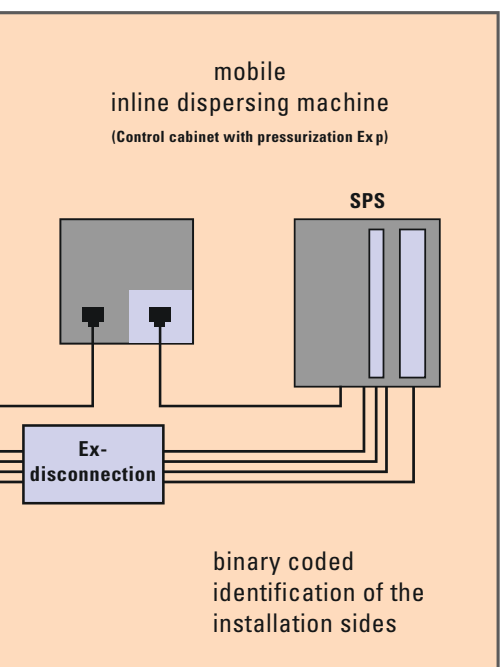

Ex px control for mobile dispersing machine



Products and solutions for cleanrooms and isolators







in use all around the world



Selangor, Malaysia



Houston, USA



Chennai, India

Competence Centre  
in Waldenburg, D



Assembly of audible and visual  
signalling devices (brand Clifford + Snell)  
in Chennai, IN



Assembly of switch cabinets  
in Waldenburg, D





Hengelo, Netherlands



Stavanger, Norway



Waldenburg, Germany



Weimar, Germany

# “We live open communication.”

R.STAHL is at home all over the world and we are always close to you. Competent teams fulfil our customer’s wishes with great commitment and harmonize them with the country-specific and environmental conditions. Whether hot or cold, whether acid or abrasive, R.STAHL’s system solutions are always safe and explosion-protected. They are utilized all over the world in the pharmaceutical industry, in rough offshore operation, in extremely low or extremely high temperatures. All standard components fulfil degree of protection IP 66, suitable for all typical applications. Our concepts have already been tested and successfully applied in many projects all around the world.

- > more than 70 subsidiaries and partners all over the world
- > modern local logistics centres all over the world
- > extensive after-sales-service
- > international training courses

Assembly of distribution panels (series 8146) in Hengelo, NL



Overview of container assembly hall in Hengelo, NL



Assembly hall for large-scale production in Waldenburg, D





R. STAHL  
Am Bahnhof 30  
74638 Waldenburg · Germany  
T +49 7942 943-0  
F +49 7942 943-4333  
info@stahl.de

 [www.stahl.de](http://www.stahl.de)

