

# Enclosure Closing Systems

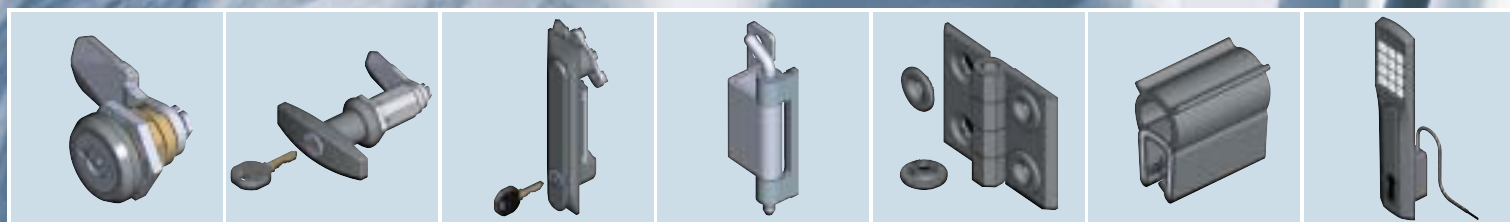

ELECTRICAL PANELS	MACHINE TOOLS	AIR CONDITIONING, HEATING AND VENTILATION	AUTOMATION
-------------------	---------------	---	------------



Excellence at Work

# Conception to production...

# "Excellence at Work"



EMKA Group – worldwide partner of the industry:

- Locking technology
- Hinges
- Gasketing
- Accessories
- Customer specific parts
- Tool and mould making

Based on a modular range of designs, EMKA develops and produces innovative hardware for the manufacture of enclosures. EMKA's expertise has been achieved by a profound knowledge of the worldwide market, and years of high production experience.



The various production processes are spread across EMKA's manufacturing centres in line with economic and logistic considerations. Some 18,000 modular components are the solid foundation for the unique EMKA product range. Numerous custom parts supplement the standard catalogue products to provide a custom look or function.



Idea    Development    Design model    Functional prototype    Drawing    Tool construction    Production    Product

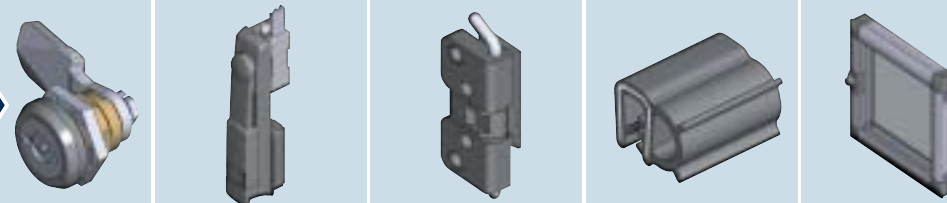

200ms laboratory for life cycle and endurance tests, IP-rating tests



The latest tools help to develop and to produce a new product on it's way from the idea to the complete product.

- 3D-onscreen animation including collision control via simulated motion-sequences
- Static analysis by means of the FEM method
- Design studies, rapid-prototyping models
- Functional prototype in low volume production by vacuum-casting technique
- Overlapping data exchange with CAD, CAE, Moldflow, CAM and CAQ
- Verification by test samples, long term and accelerated tests in our own laboratories

The quality of tools, machines and processes is documented in great detail. We are certified by Germanischer Lloyd for both quality and environmental management according to ISO 9001 and 14001.

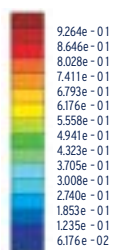
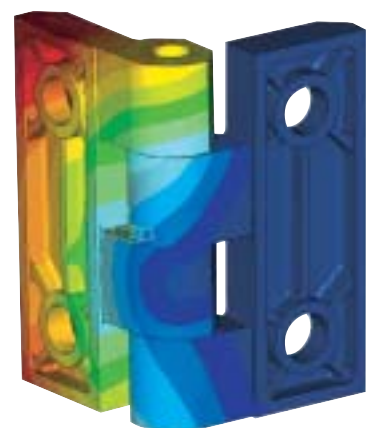

Using FEM to help optimize product design

### Development engineering

- CAD based product development
- 3D interference control and function control
- design models and functional prototypes

### Tool and mould making

- highly qualified staffs
- ultra modern EDM machinery
- engineering and production are adjacent

### Die casting technology

- more than 30 die casting machines (20t - 315t)
- making various parts up to 2.5 Kg (5.5 lbs)

### Machining

- 30 CNC milling machines, lathes, and transfer machines
- capability to produce cross-holes, hexagons etc.

### Presses

- more than 40 bending, punching, and stamping machines (up to 250t)
- processing of mild and stainless steel, aluminium or brass

### Plastics

- approx. 50 injection moulding machines (30t - 250t)

### Seal technology (foam-in-place)

- fully automated application: captive sealing gaskets
- sealing up to IP 66 (NEMA 4X)

### Surface coating

- 4-zone pre-treatment, powder coating and baking in one production line
- Approx. 1,000,000 pcs/month capacity

### Window manufacturing

- customised windows and doors
- with or without frames

### Assembly

- automated assembly
- component manufacturing

# Products "Made by EMKA"

# Modular solutions



Many solutions are possible for the enclosure manufacturing industry by using EMKA's standard hardware products, so that co-ordinated components can be used to make different styles of enclosures.

A broad standard range is available to solve all usual application requirements. Numerous customised solutions utilising existing components and/or new designs are available. Because of EMKA's extensive professional experience and deep knowledge of worldwide markets we can provide optimal solutions.

Combined mechanical and electronic components allow new opportunities:  
EMKA's ELM security systems solve the following problems:

- Locking
- Protecting
- Monitoring
- Controlling the environment
- Alarm

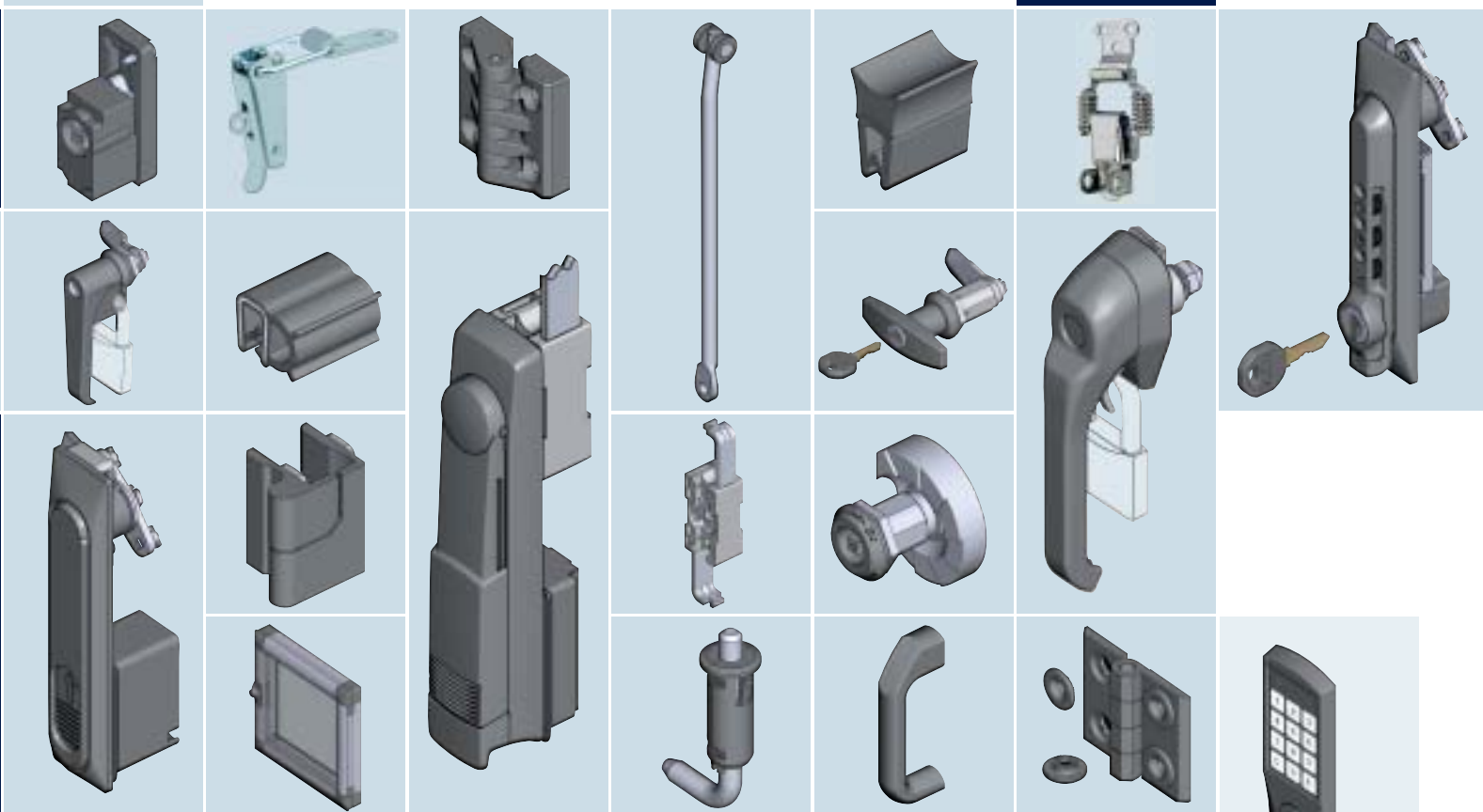

Locks, Latches

Locking systems

Hinges

Gasketing

Windows, doors

Stainless steel products

Accessories

Electronic systems

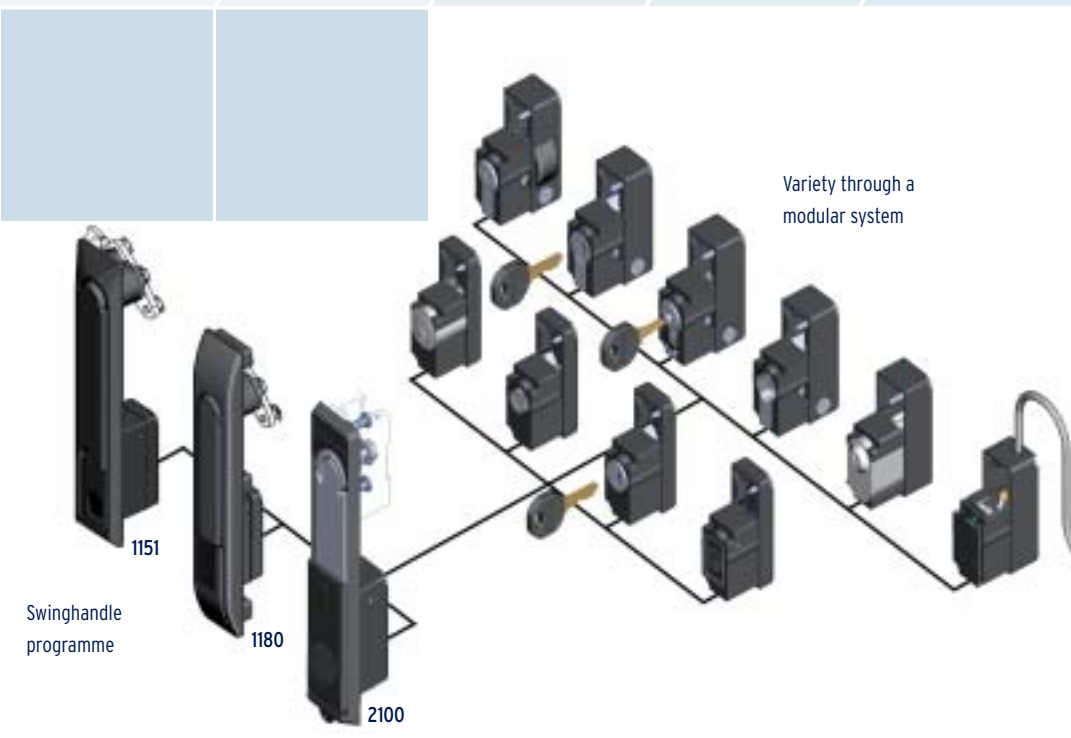

Variety through a modular system

Swinghandle programme

### Locks:

- Quarter turns
- Swing handles
- Locking handles
- Electronic Locking System
- 3 Point Locking
- Heavy duty latches
- Lift and turn latches
- Vibration proof locks
- Slam latches
- Rod controls and rods

### Hinges:

- 180° hinges
- Concealed hinges
- Lift-off hinges
- Pin hinges
- Additional options
- For in line cabinets
- Adjustable hinges

### Stainless steel products

- Locks
- Handles
- Hinges
- Accessories

### Gaskets:

- For IP 65 (NEMA 4X)
- EMI gaskets
- Edge protection
- Window rubber profiles

### Windows/doors

- Aluminium windows
- View panels
- Complete doors

### Accessories:

- Pull handles
- Door stops & stays
- Keys
- Drawing pockets

### Electronic locking systems

- Locking technology
- Access control
- Sensors, actuators
- ELM control software

## For each sector of industry...

## ... Typical applications



In the area of

- Electrical machinery
- Engineering
- Air conditioning technology
- Automatisations

Most EMKA products comply with or exceed typical industry standards. Our products are modular; this allows many different components to be used in different combinations giving an almost unlimited flexibility of appearance and function using standard parts, without basic design changes.



Full awareness of regulations and technical requirements in global markets provides a basis for broad advice so that a fast attainment of customised solutions is possible.

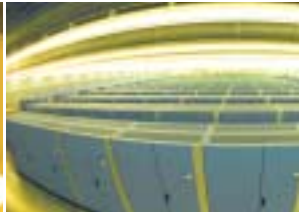

worldwide expertise

modular system

customised solutions

extensive stock

proximity to customers

high availability

close service network

closing system „made by EMKA“



The EMKA group is present in more than 60 countries worldwide:

- 5 manufacturing bases
- 40 subsidiaries/agencies
- more than 850 employees worldwide

Certifications:

ISO 9001  
ISO 14001



NEMA-tests and IP-rating tests in accredited testing laboratories. UL-listings for gaskets. Achievement of required VDE standards, national and international safety standards. Documented ROHS conformity.



### Closing Systems for the enclosure manufacturing industry

#### Electrical machinery

- control cabinets
- power distribution
- control rooms
- control panels

#### IT & Communications

- Data cabinets / cubicles
- network facilities
- server cabinets/racks
- Co-location/data centers

#### Machine tools

- Covers
- Doors
- Control panels

#### Air conditioning technology

- Compressors
- Air handling units
- Chillers

#### Automation

- Robots
- Special purpose machinery
- Manufacturing technology

As well as:

Building services engineering

Traffic control systems

Special vehicle construction

Rail vehicle manufacturing

Special designs

General sheet metal fabrication

# EMKA Subsidiaries



EMKA Beschlagteile Ges.m.b.H.  
Intercity Park 4  
A - 2421 Kittsee • Austria  
Tel.: +43-2143-43063  
Fax: +43-2143-43064  
info@EMKA-beschlagteile.at • www.EMKA-beschlagteile.at



EMKA France SA  
Route des Roches - B.P. 12  
41400 Bourré • France  
Tel.: +33/254/320862  
Fax: +33/254/324598  
EMKA@EMKA-france.com • www.EMKA-france.com



EMKA-Polska Sp. z o.o.  
ul. Siemonska 11  
42-503 Bedzin • Poland  
Tel.: +48/32/3606026  
Fax: +48/32/2633739  
info@EMKA.net • www.EMKA.net



Belgium • EMKA Benelux B.V.  
Marconiweg 2  
5466 AS Veghel • Netherlands  
Tel.: +31/413/323510  
Fax: +31/413/354425  
info@EMKA.org • www.EMKA.org



EMKA Hellas  
47-49 Hatzikiakou Ave  
185-38 Piraeus • Greece  
Tel.: +30/21041/83000  
Fax: +30/21041/83183  
info@EMKA-hellas.com • www.EMKA-hellas.com



EMKA Ferragens Portuguesa Lda.  
Rua Francisco Romero, 65  
Amoreira  
2645- 197 Alcabideche • Portugal  
Tel.: +351/214663355  
Fax: +351/214670475  
mail@EMKA.pt • www.EMKA.pt



EMKA Bosnia d.o.o. Goražde  
Ibrahima Popovica 32  
73000 Goražde • Bosnia-Herzegovina  
Tel.: +387/38/241310  
Fax: +387/38/221474  
info@EMKA.ba • www.EMKA.ba



EMKA Beschlagteile  
Kereskedelmi Képviselet / Kresz Géza u. 51.  
H-1132 Budapest • Hungary  
Tel.: +36/1/2360032  
Fax: +36/1/4510327  
info@EMKA.hu • www.EMKA.hu



S. C. EMKA Beschlagteile S. R. L.  
Alba Iulila 110  
550052 Sibiu • Romania  
Tel.: +40/269/222700  
Fax: +40/369/303700  
info@EMKA.ro • www.EMKA.ro



EMKA Industrial Hardware Co.Ltd.  
No.15 Fuyuan Road  
Wuqing Development Area  
Tianjin, 301700 • China  
Tel.: +86/22/82123759  
Fax: +86/22/82127759  
info@EMKA.cn • www.EMKA.cn



EMKA India Panel Accessories P Ltd.  
No47 J.C. Industrial Estate / 8th Main, Kanakapura Road  
Bangalore-560 062 • India  
Tel.: +91/80/26660212  
Fax: +91/80/26662706  
s.venkat@EMKA.in • www.EMKA.in



Serbia • EMKA Okovi d.o.o.  
Branimirova 64  
HR-35000 Slavonski Brod • Croatia  
Tel.: +385/35/270073  
Fax: +385/35/410900  
p.teglovic@emka-okovi.hr • www.emka-okovi.hr



EMKA Okovi d.o.o.  
Branimirova 64  
HR-35000 Slavonski Brod • Croatia  
Tel.: +385/35/270073  
Fax: +385/35/410900  
p.teglovic@emka-okovi.hr • www.emka-okovi.hr



EMKA Italia S.r.l. Unipersonale  
Via Isidora, 10  
37017 Lazise (Verona) • Italy  
Tel.: +39/045/6471070  
Fax: +39/045/6471126  
info@EMKA.it • www.EMKA.it



EMKA Kovánie  
Máchova 47  
82106 Bratislava • Slovakia  
Tel.: +421/2/45259910  
Fax: +421/2/45259910  
miro.EMKA@ba.telecom.sk



CR • EMKA Kovánie/Beschlagteile für CR a  
Máchova 47  
82106 Bratislava • Slovakia  
Tel.: +421/2/45259910  
Fax: +421/2/45259910  
miro.EMKA@ba.telecom.sk



Montenegro • EMKA Bosnia d.o.o. Goražde  
Ibrahima Popovica 32  
73000 Goražde • Bosnia-Herzegovina  
Tel.: +387/38/241310  
Fax: +387/38/221474  
info@EMKA.ba • www.EMKA.ba



EMKA España S.A.  
C/Físicas, 37  
Polígono Industrial Urtinsa II  
28925 Madrid Alcorcón • Spain  
Tel.: +34/91/6432087  
Fax: +34/91/6434207  
mail@EMKA.es • www.EMKA.es



EMKA Benelux B.V.  
Marconiweg 2  
5466 AS Veghel • Netherlands  
Tel.: +31/413/323510  
Fax: +31/413/354425  
info@EMKA.org • www.EMKA.org



# EMKA Agencies

 Emil Krachten Scandinavia AB  
Industrigatan 10  
55302 Jönköping • Sweden  
Tel.: +46/36/314130  
Fax: +46/36/314131  
info@EMKA.se • www.EMKA.se

 EMKA Beschlagteile AG  
Kammistr. 5  
3800 Interlaken • Switzerland  
Tel.: +41/33/8260220  
Fax: +41/33/8260229  
info@EMKA.ch • www.EMKA.ch

 EMKA Kilit Sistemleri Metal San. ve Tic. Ltd. Sti.  
Büyükbakkalköy Mahallesi Samandira Caddesi No:6/A  
34858 Maltepe - Istanbul • Turkey  
Tel.: +90/216/5617801  
Fax: +90/216/5617803  
info@emkakilid.com.tr • www.emkakilid.com.tr

 EMKA Middle East LLC  
Member of the EMKA Group  
P.O. Box 36293  
Dubai - United Arab Emirates  
Tel.: +971/42844528  
Fax: +971/42844572  
info@EMKA.ae • www.EMKA.ae

 EMKA (UK) Ltd.  
Patricia House  
Bodmin Road  
Coventry CV2 5DG • United Kingdom  
Tel.: +44/2476/616505  
Fax: +44/2476/612837  
enquiry@EMKA.co.uk • www.EMKA.co.uk

 EMKA Inc.  
1961 Fulling Mill Road  
Middletown PA 17057 • USA  
Tel.: +1/717/9861111  
Fax: +1/717/9861080  
EMKA@emkausa.com  
www.emkausa.com

 Lock Focus Pty. Ltd.  
Victoria 3173 • Australia  
Tel.: +61/3/97981322  
locks@lockfocus.com.au

 UES (INT'L) PTY. LTD.  
Bella Vista NSW 2153 • Australia  
Tel.: +61/2/88871200  
export@uesint.com

 Normont Industrial Hardware, Canada Ltd.  
Laval (Québec) H7P 6A9 • Canada  
Tel.: +1/450/6812884  
EMKA@normont.com

 Comercializadora Becor S.A.  
Bogota • Colombia  
Tel.: +57/1/2350234  
gerencia@becor.com

 A/S Megatrade Beslag  
2650 Hvidovre • Denmark  
Tel.: +45/44916700  
mega@megatrade.dk

 Colly Components AB - Estonia  
164 94 Kista • Sweden  
Tel.: +46/8/7030100  
customerccp@colly.se

 Oy Colly Company Ab  
00391 Helsinki • Finland  
Tel.: +358/29/006150  
sales@colly.fi

 Teder Electro Mechanical  
49277 Petach-Tikva • Israel  
Tel.: +972/73/2331200  
sales@teder.com

 TOCHIGIYA Co., LTD  
101-0047 Saitama • Japan  
Tel.: +81/48/2283072  
support@tochigiya.co.jp

 Colly Components AB - Latvia  
164 94 Kista • Sweden  
Tel.: +46/8/7030100  
customerccp@colly.se

 Colly Components AB - Lithuania  
164 94 Kista • Sweden  
Tel.: +46/8/7030100  
customerccp@colly.se

 Colly AS  
1314 Vöyenga • Norway  
Tel.: +40/21/2329502  
dragos.butoi@dcb.ro

 OOO"MK-Electro  
196128 St.-Petersburg • Russia  
Tel.: +7/81/24492928  
info@mk-electro.ru

 VF Fastening Systems PTE Ltd.  
757695 Singapore • Singapore  
Tel.: +65/675/2333  
vincent@vffastening.com.sg

 Enclosure Solutions  
Benoni • South Africa  
Tel.: +27/11/4212675  
info@enclosuresolutions.co.za

 Geo Jeon Co. Ltd.  
429-450 Kyoung Gi Do • South Korea  
Tel.: +82/314/335508  
koreaemka@naver.com

 Colly Components AB  
164 94 Kista • Sweden  
Tel.: +46/8/7030100  
customerccp@colly.se

 Best Port Company Ltd.  
429-450 Kyoung Gi Do • Thailand  
Tel.: +66/2/993/5739  
bestport@samartas.com

 Terramar Engineering and Machinery (Pte.) Ltd.  
Tan Binh District, Ho Chi Minh City • Vietnam  
Tel.: +84/8/9974089  
cam@terramar.com

