

1150	1150	1150	1150	
Swinghandle 1150	Swinghandle 1151	Swinghandle 1152	Swinghandle 1153	
3C-100	3C-100	3C-100	3C-100	

Beschlagteile

see page

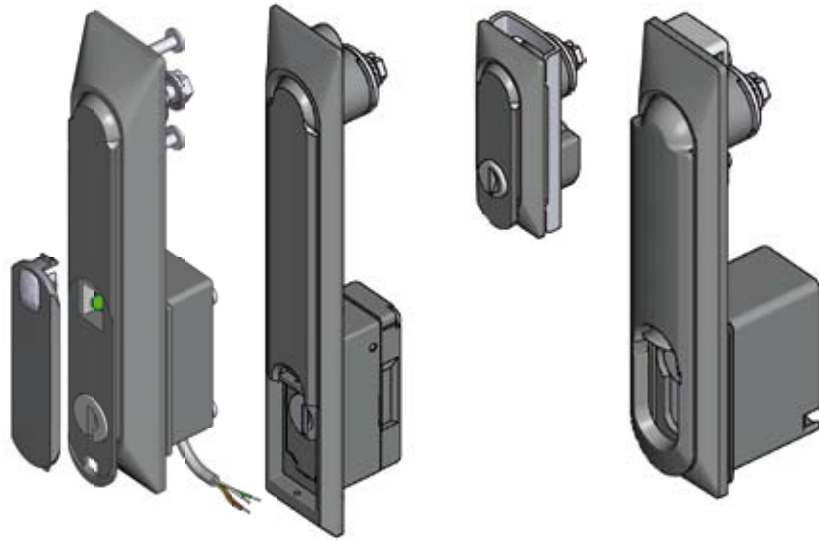

Please see next page for second part. Survey of further products.

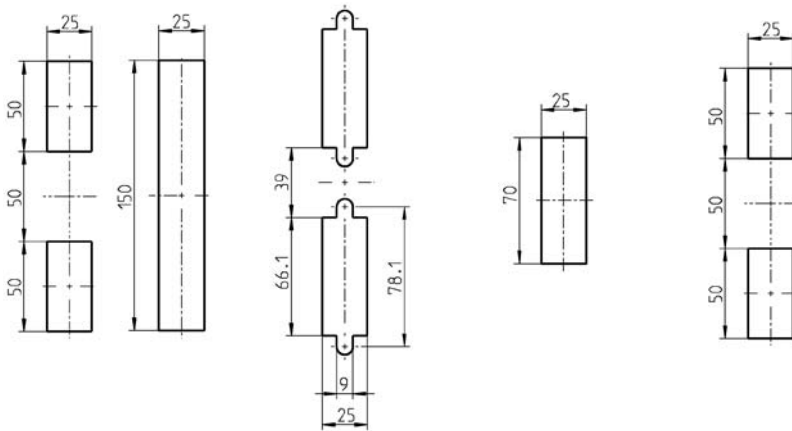

•	•	•	•	Assembling inside the gasketing
•	•			Outside the gasketing
IP 40	IP 54/IP 65	IP 40/IP 65	IP 65	Protection: IP
	•			Unlocked with insert
Emergency opening	•	•		Unlocked with round cylinder
	•		•	Unlocked with profile half cylinder
•	•			Unlocked electronically
	•	•	•	Unlocked without key
	•			Modular locking
		•		Handle and escutcheon polyamide
				Handle zinc die and escutcheon polyamide
•	•	•	•	Handle and escutcheon zinc die
				Handle and escutcheon stainless steel
				Fitting escutcheons