



When kitchens have to accommodate a number of users with varying height requirements, a frame system should be used to enable the work surfaces and/or storage units to be instantly adjusted in height, either manually or by electric motor.

Such scenarios could be a family situation, group homes, schools and colleges, or indeed any situation where multi-use is expected.

For more information on these frames please ask for our separate brochure.

Giving a lift to everyday life



scanflex® ergonomics for:

*Kitchen • Bathroom • Daily Living • Occupational Therapy • Schools & Colleges*



**Scanflex® Ltd**  
2 Thursby Road  
Croft Business Park  
Bromborough, Wirral  
CH62 3PW UK  
**t:** +44 (0)151 343 1523  
**f:** +44 (0)151 343 1514  
**e:** info@scanflex.co.uk  
**w:** www.scanflex.co.uk

flexible kitchen systems





*Side opening oven with safety non-tilt shelves*



*Pullout deep drawers and baskets are essential for chair users*



*Mobile trolleys compensate for lost storage and provide an additional work surface*



*Wall cupboards can be made completely accessible*



*Wheelchair accessible ironing boards fold away when not in use*

## The original flexible kitchen

The idea of built-in flexibility in furniture is not new. The concept was developed in Denmark in the late 1970's to ensure that all users, particularly those with limited mobility, could perform day to day tasks at their optimum working level.

System Flex® was the first kitchen to incorporate this principle and from a simple beginning has developed into a stylish and modern range of furniture to complement any home or establishment in today's demanding housing market. System Flex® was a result of co-operation between architects, occupational therapists, housing providers and the end user. It is not a contract type kitchen with a few basic add-ons, and a consideration for ergonomics plays a great part in its specification and design.

Building in this flexibility means that the kitchen can be set at one height and then easily altered to accommodate the changing needs of the user. For the architect, specifier or landlord, installing a flexible kitchen removes the need to identify specific users or tenants prior to the construction process.

In addition to built-in flexibility, System Flex® offers a host of benefits to assist those with limited mobility and those working in a multi-user environment. These include ergonomically correct base units (providing the optimum dimensions for reach and footrest clearance), durable 18mm carcass construction, friction free runners and pullouts, carousels and mobile storage units.

## Systemflex® range

The range is ideal for sheltered housing, rehabilitation and respite units, domestic adaptations, schools and colleges. It is also compatible with all the major rise and fall worktop and wall unit frame systems such as Mobil Flex®, Ropox and Pressalit, which transform the furniture into a truly multifunctional kitchen.

Add to this a range of suitable cooking appliances, accessible sinks and taps, and 30 years presence in the flexible furniture market, and Scanflex® are sure to provide you with the optimum design solution in the kitchen.

# How the system works

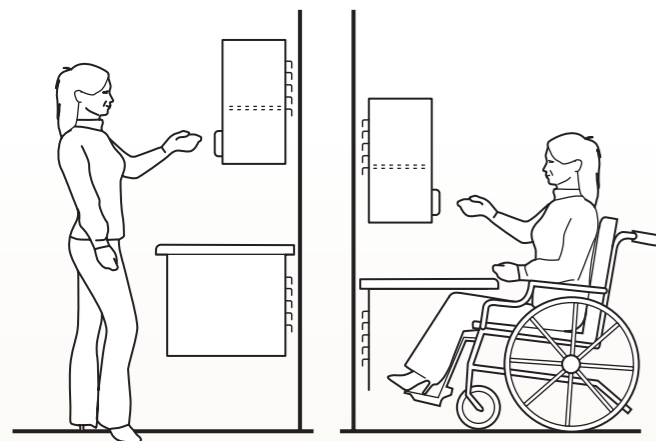
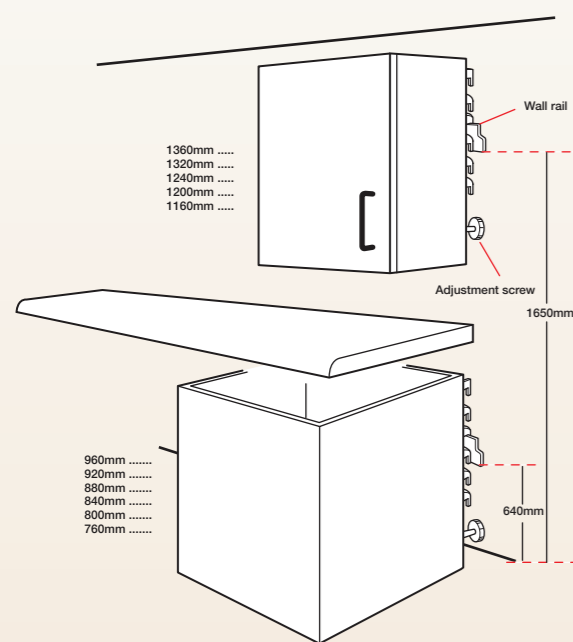

Diagram A - The Unique System Flex suspension system

Diagram B - The working levels attainable when wall rails are fixed at the optimum heights of 640mm & 1650mm



System Flex® is a suspended kitchen. A steel track or rail is fixed to the wall and the inbuilt hook suspension brackets allow the base and wall storage to be fitted at a height to suit the user and subsequently altered with ease. System Flex® will provide infrequent adjustment of 200mm. If additional or more frequent adjustment is required then our Mobil Flex® system would be better suited.

Free hanging worktop for wheelchair access is supported by adjustable brackets or consoles that also have suspension hooks. Free hanging worktop should be supported every 800mm.

Adjustment screws built into the wall and base units allow the cupboards to be levelled when the wall is not true. Support consoles are also levelled in the same way ensuring a perfect run of worktop.

Instead of using silicone to seal between the worktop and tile, a flexible rubbing strake or upstand is fitted. This is attached to the worktop and has a rubber trim top and bottom, thus enabling height adjustment without fouling and damaging the tiles.

To allow for all adjustment eventualities, tiling should commence at 600mm and finish at 1350mm from floor level (5 courses of 150 x 150mm tiles).

Scanflex® supply flexible feed and waste kits to allow sinks inset into worktops to move up and down (see page 10). Plumbing feed pipes should terminate 500mm from floor level directly beneath the bowl position.

# Furniture options













System Flex® Furniture - is manufactured within the criteria laid down by BS EN 9001:2000. All carcasses are 18mm high density MFC, making the range durable and ideal for combining with height adjustable frame systems such as Mobil Flex®, Ropox and Pressalit. Drawer systems are Metabox and comply with BS6222:Part2:1997.











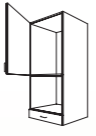
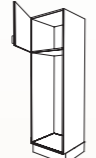
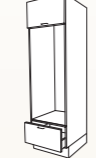

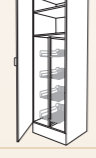
Doors are either 18mm MFC with 3mm PVC trim or 18mm MDF foil wrap. Worktops are supplied with full postform and 38mm thick as standard. For door and drawer colour options please see page 7. For worktop styles please see page 8.

Description	Ref no.	Width (cm)	Height Depth (cm)	Cubic Capacity (m <sup>3</sup> )
Empty cupboard	U-30	30	54 x 59.5	.10
	U-40	40		.13
	U-50	50		.16
Cupboard with one adjustable shelf	UH-30	30	54 x 59.5	.10
	UH-40	40		.13
	UH-50	50		.16
As above but with two doors	UH-80	80		.26
	UH100	100		.32
Cupboard with two tray type shelves on telescopic runners	UB-40	40	54 x 59.5	.13
	UB-50	50		.16
Cupboard with drawer, deep drawer and tray type shelf on telescopic runners	UB-04	40	54 x 59.5	.13
	UB-05	50		.16
Cupboard with pullout work surface, deep drawer and tray type shelf on telescopic runners	UBA-04	40	54 x 59.5	.13
	UBA-05	50		.16
Cupboard with built-in ironing board and deep drawer	UBS-04	40	54 x 59.5	.13
	UBS-05	50		.16
Cupboard with four drawers on telescopic runners	US-04-4	40	54 x 59.5	.13
	US-05-4	50		.16
Cupboard with two drawers and one deep drawer on telescopic runners	US-04-3	40	54 x 59.5	.13
	US-05-3	50		.16
	US-06-3	60		.19
Cupboard with 2 deep drawers on telescopic runners	US-04-2	40	54 x 59.5	.13
	US-05-2	50		.16
	US-06-2	60		.19
Base unit for sink with one shelf	UV-100	100	54 x 59.5	.24
	UV-120	120		.39

Description	Ref no.	Width (cm)	Height Depth (cm)	Cubic Capacity (m <sup>3</sup> )
Corner unit with one shelf (400 door) (500 door) (600 door)	UHH-40	100	54 x 59.5	.24
	UHH-50	100		.24
	UHH-60	100		.24
Corner unit with two carousel shelves	UHS-50	100	54 x 59.5	.24
	UHS-60	100		.24
Corner unit with drawer and shelf	UHH-04	100	54 x 59.5	.24
	UHH-05	100		.24
Corner unit with drawer and one carousel shelf	UHS-05	100	54 x 59.5	.24
	UHS-06	100		.24
Plinth with drawer to raise appliance such as refrigerator	UFK-06-1	60	54 x 59.5	.12
Open shelf compensating base unit for spaces <30cm	UHU-03	30		
<b>Note that all System Flex® base units are available in conventional form i.e. 72cm high on 15cm plinth.</b>				
Trolley with brake castors, drawer and shelf	101-S	50	63 x 59.5	.19
Trolley with brake castors, drawer and door	MUH-05	50	63 x 59.5	.19
Trolley with waste bin liner holder	101-A	50	63 x 59.5	.19
Trolley with brake castors and two deep drawers	MUS-05-2M	50	63 x 59.5	.19

# Furniture options cont.

Description	Ref no.	Width (cm)	Height Depth (cm)	Cubic Capacity (m <sup>3</sup> )
 Trolley with brake castors, two drawers and deep drawer	MUS-05-3M	50	63 x 59.5	.19
 Drawer for free hanging worktop	SA-40-12 SA-50-12 SA-60-12	40 50 60	12 x 59.5	
 Pullout work surface for free hanging worktop	SS-40-12 SS-50-12 SS-60-12	40 50 60	12 x 59.5	
 Reduced height wall unit (above hob, sink, etc)	OH-06	60	35 x 34	
 Wall unit with shelf	V-03 V-04 V-05 V-06	30 40 50 60	57 x 34	.06 .08 .10 .12
 Wall unit with pull down baskets	V-05-X	50	57 x 34	.10
 Wall unit with shelf and two doors	V-06-2 V-08	60 80	57 x 34	.12 .16
 Corner wall unit	V-03-03	60	57 x 34	.18
<b>NB All System Flex® wall units are also available in a conventional fixed version at 72 or 90cm high.</b>				
 Oven housing with top cupboard, pan drawer and pullout work surface (60cm niche)	HO-06-79A	60	204.5 x 59.5	.31
 Oven housing with top cupboard, pan drawer and pullout work surface (90cm niche)	HO-06-90A	60	156 x 59.5	.31
 Reduced height oven housing	HO-06-156	60		.24

Description	Ref no.	Width (cm)	Height Depth (cm)	Cubic Capacity (m <sup>3</sup> )
 Reduced height oven housing with top cupboard and pullout work surface (for use with Mobil Flex® & Ropox frames)	HO-06-135	60	135 x 59.5	.21
 Refrigerator housing with top cupboard	HK-06-139	60	204.5 x 59.5	.12
 Refrigerator housing with top cupboard and pan drawer	HK-06-127	60		.31
 Tall cupboard with five shelves	HH-04 HH-05 HH-06	40	204.5 x 59.5	.49 .61 .73
 Tall cupboard with three pullout trays and two fixed shelves	HHB-04 HHB-05 HHB-06	40	204.5 x 59.5	.49 .61 .73
 Tall cupboard with four pullout baskets and two fixed shelves	HHU-06	60		.73
 Worktop (bullnose)	FORM-38	Up to 300		
 Fascia/downstand (for fitting below free hanging worktop)	SL-200-12	200	120 x 18	
 End panel	GPUT	18	87 x 59.5	
 Support console for free hanging worktop	KONS	3	45 x 54	
 Wall rail	VAEG-05	120		
 Jointing strip	JS			
 Rubbing strake (flexible worktop seal)	BKL-P25	250	4 x 4	
 Cornice	COR	250		
 Light pelmet	PEL	250		
 Pullout tandem waste bin (re-cycling)	PRB 30, 40, 50			

# Door & drawer finishes



## Group One

A range of 18mm melamine MB Extra doors manufactured to withstand impact and inevitable hard usage. The doors have a 3mm bonded PVC trim.

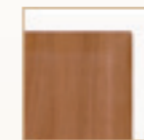
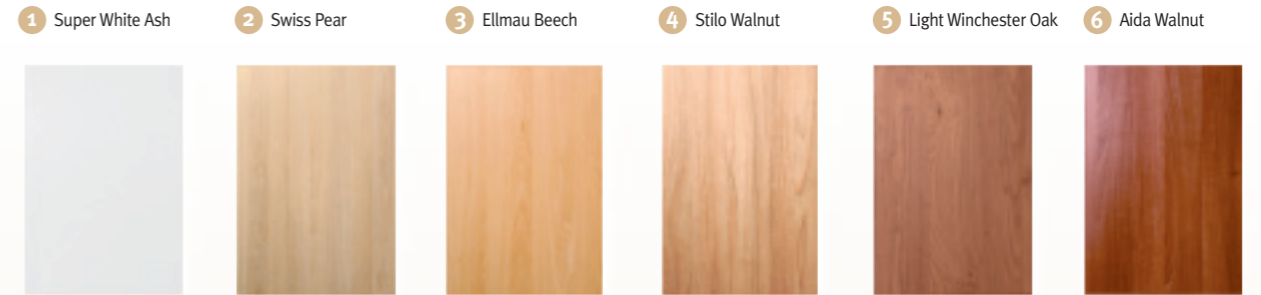

## Group Two

These doors are manufactured from 18mm MDF, which is foil wrapped. The edges are chamfered giving a stylistic modern appearance.

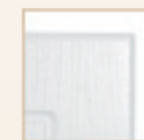

## Group Three

Sculptured 18mm MDF doors with rounded edges for a more classical feel to the kitchen.

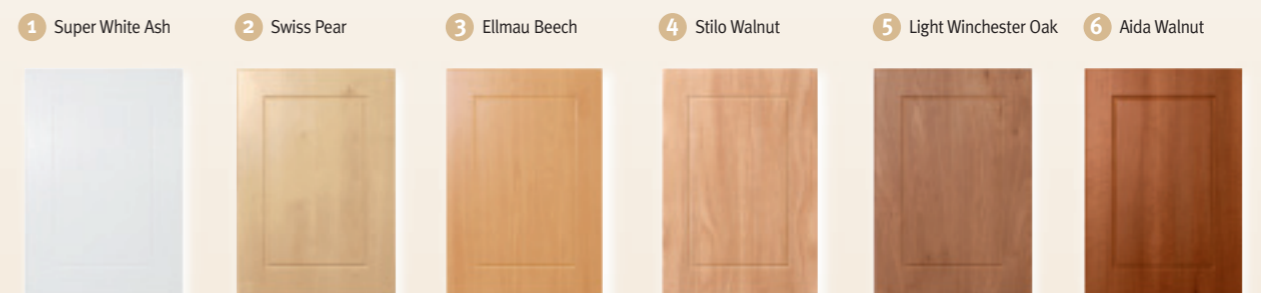

Colours available are subject to alteration and this selection was correct as at June 2008. Sample reproduction is as close as the printing process will allow.



# Worktop finishes

Scanflex® textured worktops are supplied 38mm thick with full postform as standard. Complying with BS EN438, each top has built in Microban® antibacterial protection.



1 Etna Verde



2 Kota



3 Steamed Beech



4 Cosmic Beige



1 Maryland Fonce



2 Nova Sapphire



3 Carthage

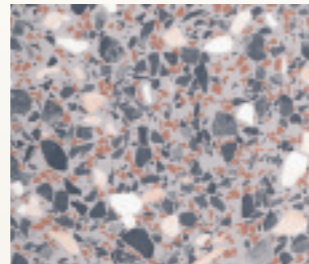

4 Granito Fonce

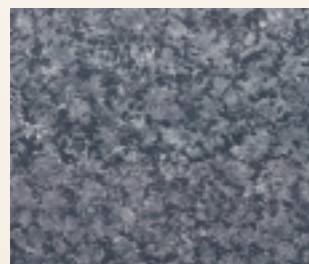

1 Dakota

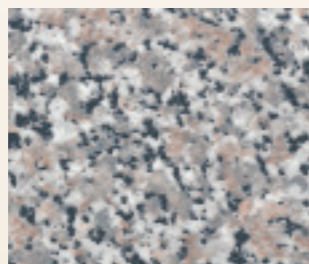

2 Granite Beige

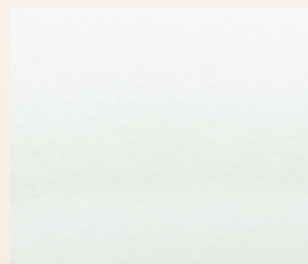

3 Blanc Megeve



4 Beech Normand

Colours available are subject to alteration and this selection was correct as at June 2008. Sample reproduction is as close as the printing process will allow.

# Easy access appliances



An essential feature of a kitchen which has been designed with the disabled or infirm user in mind is the choice of easy to reach appliances which are both safe to use and accessible.

Scanflex® have sourced a number of appliances which incorporate these useful features and complement our range of System Flex® and Mobil Flex® height adjustable kitchen ranges.



### TURBO MULTIFUNCTION OVEN

#### OX60011G

- Fanned electric turbo oven
- Multifunction
- Stainless steel exterior
- Dual circuit grill
- Triple glazed cool touch hinged glass door
- Electronic timer/programmer
- Fast pre-heat
- Side opening door for easy access
- Safety non-tilt shelf system



### FOUR ZONE CERAMIC HOB

#### ZKF641

- Four fast heat zones
- Residual heat indicators
- Easy reach front controls
- Low profile for easy pan transfer
- Wipe clean ceramic glass surface



### SOLID PLATE ELECTRIC HOB

#### HEK411

- Four solid plate cooking zones
- Six control positions
- Front mounted control knobs
- On/off indicator
- Stainless steel
- 590mm wide

### SOLID PLATE HOB

#### ZBE603X

- Easy reach front controls
- Fast heat zones
- Stainless steel
- Six control positions

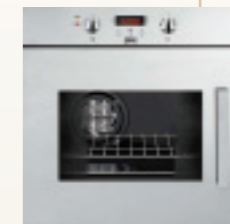

### MULTIFUNCTION OVEN

#### ZOB550XL

- ThermoFlow® fan operated cooking
- Multifunction
- Side opening door
- Thermal grilling
- Simple electronic controls



### GAS HOB

#### HG6111B

- Four variable burners
- Ignition integrated into control knobs
- Cast iron pan supports
- Front mounted controls
- 600mm wide



### TWO ZONE INDUCTION HOB

#### N1262

- Two power boost settings
  - Two stage residual heat indicators
  - Easy reach front controls
  - Low profile for easy pan transfer
  - Wipe clean ceramic glass surface
- Also available in an induction version – N4262

### TRADITIONAL COOKER HOOD

#### EFT60001X

- Three speed extraction
- Optional charcoal filter
- Metal grease filter
- Stainless steel



Scanflex® can also supply a range of refrigerators and freezers. Whilst these appliances have no specific features which could benefit the less able user they have been chosen for their reliability, low maintenance and comprehensive extended warranties.



# Easy access taps & sinks

Conventional cross or crystal head taps often prove difficult to operate for those with limited strength, dexterity and reach. Scanflex® supply a number of tap types and styles which will accommodate almost all types of user. All taps can be used in conjunction with System Flex®, Mobil Flex® and Ropox kitchen ranges.



- DAMIXA**  
**15010 Kitchen Sink Mixer**
- Single lever operation
  - Anti-scald option
  - Water saving feature
  - Non-allergenic ergonomic handle
  - 215mm swivel spout (120°)



- SHAVRIN**  
**710 Kitchen Sink Mixer**
- Swan neck swivel spout
  - Dual flow
  - Lever operation
  - 120° swivel spout
  - Ceramic cartridge for ease of use



- DEVA**  
**T-2 High Neck Lever Taps**
- High neck spouts
  - 75mm chrome plated levers
  - 1/4 turn operation
  - 150mm lever option available



- DEVA**  
**DM-20 Deck Mounted Mixer**
- Swivel spout
  - 75mm levers
  - 1/4 turn operation
  - 150mm lever option available



- SHAVRIN**  
**T-5 Single Lever Mixer**
- Swivel spout
  - 75mm lever
  - Dual flow spout
  - Chrome plated finish

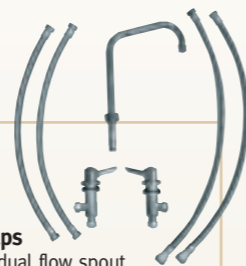

- SHAVRIN**  
**711M Remote Taps**
- Deck mounted dual flow spout
  - Independent panel valves
  - 75mm chrome levers
  - Tap heads can be mounted in worktop, fascia panel or dummy drawer

- LEISURE**  
**S-2 Sink**
- Shallow bowl depth 150mm
  - Two tap hole
  - Bonded heat pad to protect users' legs
  - Overall size 950 x 508mm
  - Available with single diagonal tap hole reference S-1 (inset) (reversible – 950 x 508mm o/a)
  - A single bowl reversal drainer sink (diagonal tap hole) with a bowl depth of 100mm is also available ref: S-4. If space is at a premium consider an 860 x 435mm reversible drainer sink with 150mm shallow bowl ref S-3.

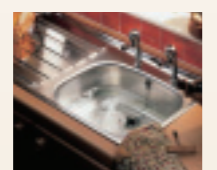

↑ S-2 Sink



↑ S-1 Sink



- PANDA**  
**EK 460 Sink Bowl**
- Shallow bowl depth 145mm
  - Overall size 460 x 400mm
  - Also available with bowl depth 100mm



- SCAN**  
**FX-1 Flexible Feed & Waste Kit**
- Allows full height adjustment of sinks
  - 2 x 500mm flexible tap connectors
  - Bottle trap with fully flexible hose

# CAD services



With almost 30 years' experience in providing kitchens for the less able, where else would you expect to obtain the optimum design for the end user?

Scanflex® are able to provide you with a state of the art rendered isometric representation of how the finished kitchen will look. This is particularly useful in visualising how a chair user will manoeuvre in the space available.

To assist architects and contractors, detailed plan drawings are available as well as M & E elevations to show exactly where services and electrics should be placed. This is especially important when considering the installation of electrically adjustable frames such as those in the Mobil Flex®, Ropox and Pressalit ranges.

This service is provided free of charge to all those planning for domestic adaptations, sheltered housing schemes and educational establishments.

Nationwide site surveys and technical meetings are also available upon request.



A typical Scanflex® kitchen presentation giving a realistic interpretation of how the installation might look. Our design and estimating department accepts enquiries in all formats including AutoDesk and AutoCAD (.dxf & .dwg files).