

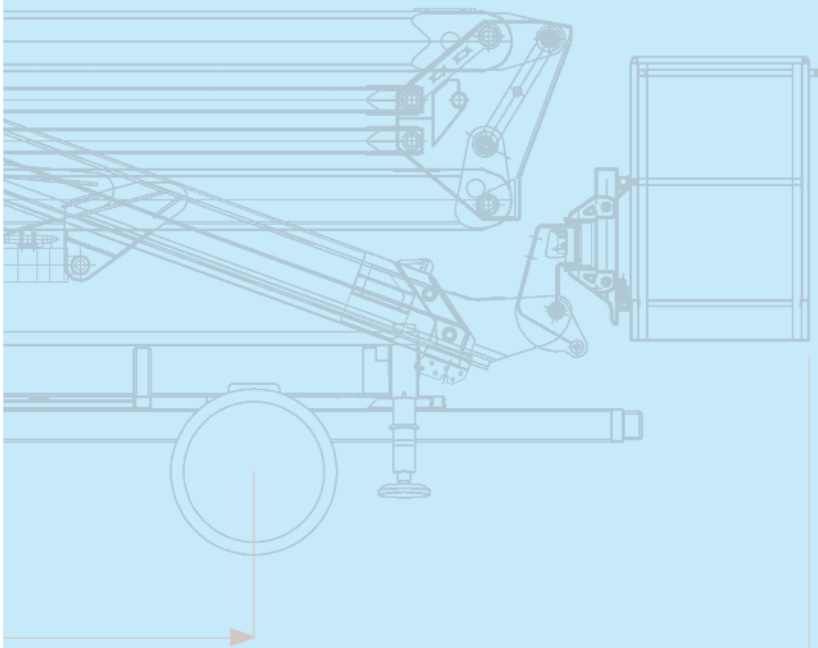

# RAM® Gemini 17 PT

Aerial Work Platform

PROOF

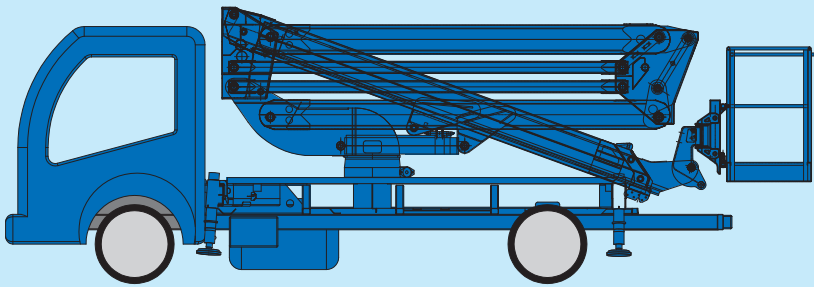

- **Very Compact ideal for city use** - total length 6.6m and only 2.28m high
- **Aluminium tough cage with flush-mount base** - for easy entry and better for roof work
- **Quick-release basket** - for ease of transport and maintenance
- **Unrestricted working area** - the max outreach with a payload of 200kg is 9m without rotating the basket
- **180° Basket rotation**
- **Super low centre of gravity** - important for stable driving and extra clearance

**HLS**   
HEIGHT, LIFT & SHIFT  
Safe & productive workplace solutions

- **Sales (New and Used)**
- **Contract Leasing**
- **Training**
- **Service and Parts**



# Gemini 17 PT

Aerial Work Platform

## Standard Specification

### Specification

WORKING HEIGHT	17 m
MAX OUTREACH	9m
PLATFORM CAPACITY	200kg
BASKET DIMENSION	1300 x 700 x 1100mm
BASKET ROTATION	180° (+/- 90°)
TURRET ROTATION	440°
OUTRIGGERS	H frame system

### TRAVEL DIMENSIONS:

TOTAL HEIGHT	2.28m
TOTAL LENGTH	6.63m (6m without basket)
TOTAL WIDTH	2.10m

VEHICLE: Nissan Cabstar 35:11 Hi Payload,  
LWB 2.5Dci Euro5 120 HP 5-speed

### Gemini 17 PT Standard Specification Includes:

- Double pantograph and telescopic boom
- Fully proportional with electro hydraulic ramped control
- Automatic turret centring function
- Cab PTO / outrigger warning system
- Quick release platform
- Aluminium tough cage with flush-mount base
- 440° turret rotation
- 180° hydraulic basket rotation
- Hour meter
- Standard boom colours red (RAL 3020)

### Options:

- Automatic self-levelling H-frame system
- Auto cab protect system
- Full cab anti-collision system
- 110/240V power to platform
- Flashing beacon/s to cab

### Warranty:

#### Super Structure:

- 1 year parts and labour
- 2 years on electronic card
- 10 years structural

#### Chassis Cab:

- Nissan 3 year or 100,000 kms

## Technical Specification

