



Gemini
20.35 PTJ

Effective compact
and versatile
vehicle mounted
access platform





Gemini 20.35 PTJ

- 3400 kilo road weight (with full tank of fuel ex driver)
- Super low centre of gravity makes for stable driving and extra clearance
- H frame auto jack system with city function - easy set up in confined spaces
- Free on wheels duty up to 14 mtrs - ideal for repetitive moves
- Radio control as standard - smooth precise controls with enhanced safety
- 11 metre outreach - unrivalled in its class
- Fly jib as standard - for those difficult jobs
- Aluminium tough cage with flush mount base - for easy entry and better for roof work



Auto Start stop

Auto shut down and re start when next function is requested. Save Fuel and reduce CO² emission and noise pollution.



Data Connect

Connect via LAN, WIFI, GPRS or GSM anywhere in the world, direct to the engineers for full diagnostics or to upload new settings, can also be used to monitor machines usage.



Radio Control

Smooth & precise control at a safe distance, with over 200 channels and ability to use as diagnostics tool.





Specification

Working height:	20.35m
Max outreach:	11m
Jib:	110° (-100°/+10°)
Upper boom:	-20°/+80°
Lower boom:	0°/+85°
Load capacity:	200 kg
Basket in aluminium:	1.4m x 0.7 x 1.1m
Basket rotation:	+/- 80°
Turret rotation:	+/- 220°
Outriggers:	H frame system with narrow jack option at 1960mm and std front jack to 2160 dual safety circuit fitted

Driving dimensions

Total height:	2.25m
Total length:	6.68m (5.98m with the basket)
Total weight:	3400 kilos (with Full tank of fuel ex driver)
Vehicle:	Nissan Cabstar 35:11 Hi Payload LWB 2.5 Dci Euro5 120 HP 5 speed

Standard

Gemini 20.35 PTJ Standard specification Includes:

- Fully proportional with electro hydraulic ramped control
- Automatic Self level H Frame system
- Radio Control with interactive display and diagnostics function
- Automatic Centring function
- Auto cab protect system
- Cab PTO warning light display panel
- Double pantograph jib allowing 10 mtrs vertical lift
- Free on wheels operation up to 14 metres
- Auto Start stop function

*Optional Extras:

- Out rigger foot plates
- Air/water tube to platform
- 110/240 volt power to platform
- 110/240 volt electric controls (for indoor use)
- Flashing warning beacons to cab
- In cab or remote radio control battery charging point
- 68 Mph speed limiter
- Colour choice to cab and superstructure

*May effect road weight

Warranty

Super Structure:

- 1 year parts and labour
- 2 years on electronic card
- 10 years structural

Chassis Cab:

- Nissan 3 year or 100,000 kms

Technical Specification

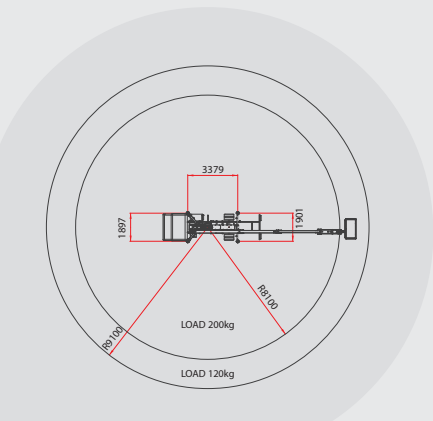
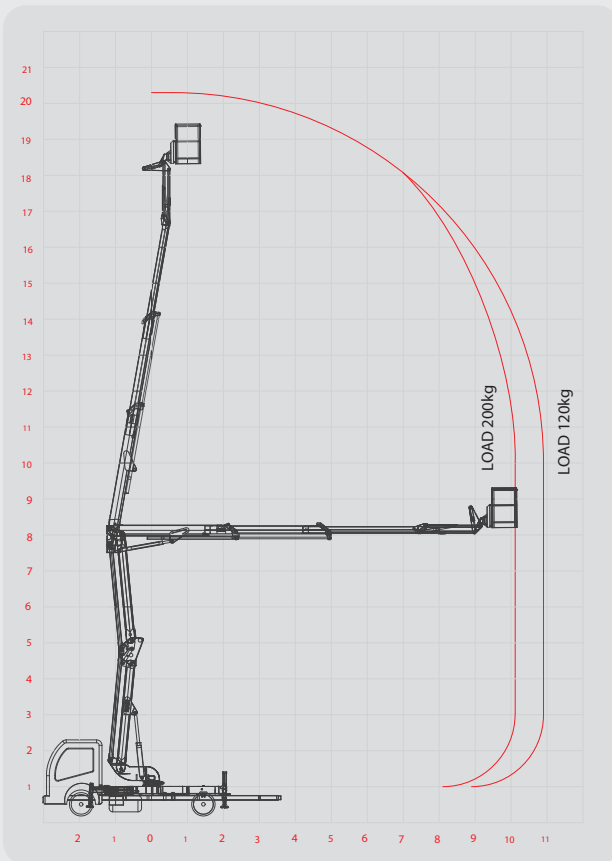

Minimum Stabilisation Area

