

Mast Boom Lifts

JLG Model Toucan 10E

Platform

0.90m x 0.70m(WxL) steel platform
 Slide bar rear entry
 Full proportional drive and slew joystick control with integral thumb steer switch
 Mini joysticks provide proportional lift/lower and jib function control
 1.60 m articulating jib
 Function enable with enlarged LED function status display
 Load sensing system
 Large tool tray

Power & Transmission

Two wheel direct electric drive
 Brushless AC drive motors
 24V-240 A/hr full traction batteries
 On-board 110/230V HF battery charger
 Powered battery fill
 Auto power save when idle
 Low charge function cut-out
 On-board diagnostics with integral display
 Automatic rear wheel brakes
 Sculptured polyester hoods

¹ Circuit breaker included with AC cable to platform option. NB Plug type and voltage must be specified.

Functional Equipment & Accessories

Heavy duty steel roller mast with 345° rotation
 Chain slack detection system
 2 degree tilt alarm and indicator light
 406 x 125 solid non-marking tyres
 Passive pothole protection system
 0.99 m wide frame
 Lifting/tie down rings
 Ground control selector switch with key lock
 Battery discharge indicator
 Hour meter
 Horn
 Drive orientation system
 Lanyard anchor points
 Xenon strobe light
 Manual descent system

Available Options

AC power cable to platform with plug and socket ¹
 8 mm air line to platform
 24V-240 A/hr Gel batteries with 230V on-board battery charger
 Acoustic alarm
 70W Platform worklight
 Food compatible lubricants
 Low temperature lubrication



	Toucan 10E
Working height	10.10 m
Platform height	8.10 m
Horizontal outreach	3.08 m
Up and over height	6.51 m
Swing (not continuous)	345°
Platform capacity	200kg ¹
Jib - overall length	1.60 m
Jib - range of articulation	+66° / -61°
A. Platform size (W x L)	0.90 x 0.70 m
B. Overall width	0.99 m
C. Tailswing	13 cm
D. Stowed height	1.99 m
E. Overall length	2.82 m
F. Wheelbase	1.20 m
G. Ground clearance	10.5 cm
Machine weight	2990 kg ²
Maximum ground bearing pressure	21 kg/cm ²
Drive speed - lowered	5.5 km/h
Drive speed - elevated	0.75 km/h
Drive speed - full elevation	0.40 km/h
Turning radius (outside)	1.99 m
Turning radius (inside)	0.55 m
Gradeability	25%
Max. allowable tilt angle	2°
Distance from platform to wall - over front	0.00 m
Distance from platform to wall - over sides	0.00 m
Tyres (non-marking solid)	406 x 125 mm
Electrical system	24V DC
Batteries	24V - 240 A/hr
Charger	24V - 25A
Drive motors	Dual AC motors
Brakes	Disc
Electrical motor	3kW 24Vdc
Hydraulic system	9 L

¹ Capacity shown is maximum two persons indoor and outdoor (12.5 m/s wind speed)

² Certain options or country standards may increase weight and/or dimensions.

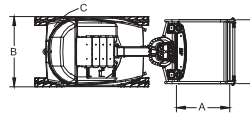
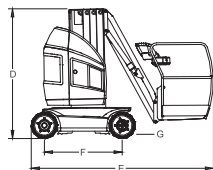
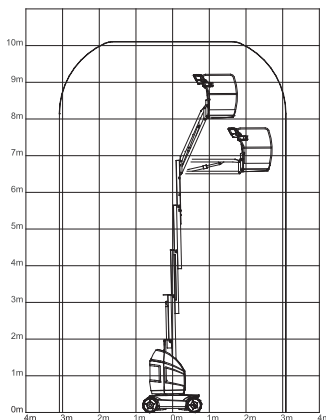

HLS

HEIGHT, LIFT & SHIFT

Safe & productive workplace solutions

t: +44 (0)113 287 8446

e: info@hls.co

www.hls.co

