

OTL Gully and Drain Dimensions

OTL Reference	Page
WH (White Top) BLK (Black Top) SS (Stainless Steel Top)	
ALGAS (Antiligature Stainless Steel Top)	
OTL Drains for Level Access and Wet Room Floors	
OTL TSG 1 WH / BLK / SS	2
OTL TSG 52 (116) WH / SS	3
OTL TSG 50 WH / BLK / SS	4
OTL TSG 2 WH / BLK / SS	5
OTL USG 1 WH / BLK / SS	6
OTL USG 3 WH / BLK / SS	7
OTL Drains for Linear Floors	
OTL TSG 50 LN	8
OTL TSG 2 LN	9
OTL TSG 1 LN	10
OTL USG 1 LN	11
OTL USG 3 LN	12
OTL Linear Main Chanel Assembly	13
OTL Drains for Resin Floors	
OTL ST90-HPB	14
OTL Resin Drain Assembly	15
OTL Drain Accessories	
OTL FGTR125 Top	16
OTL Antiligature Top	17

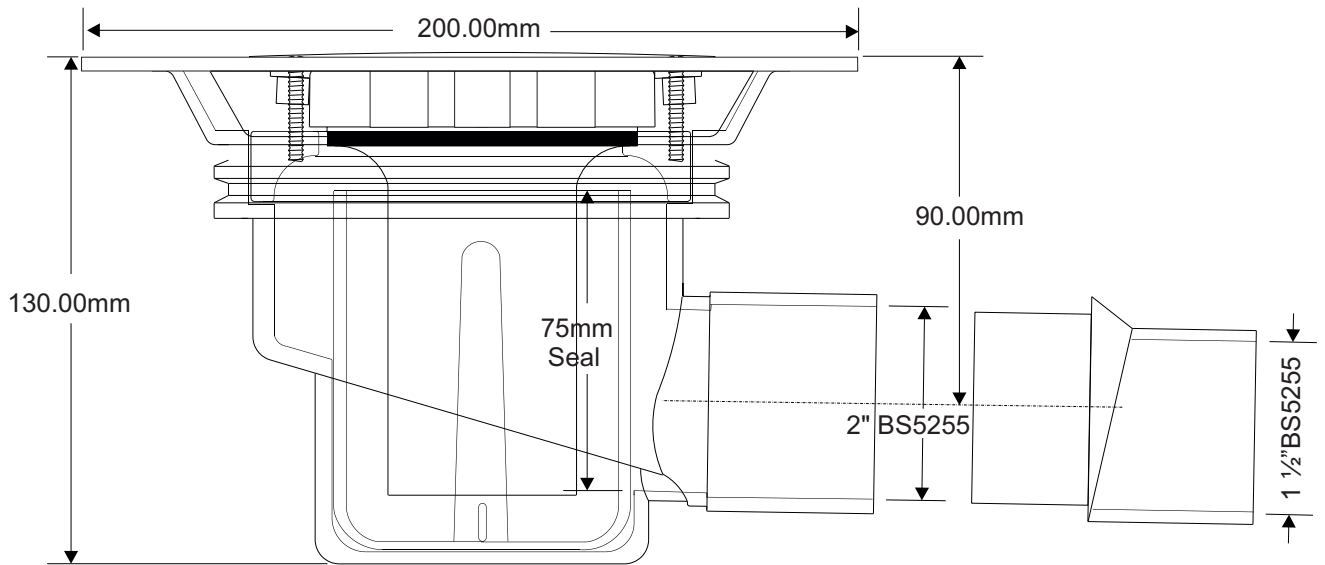

OTL TSG 1 WH / BLK / SS





OTL TSG 50 WH / BLK / SS

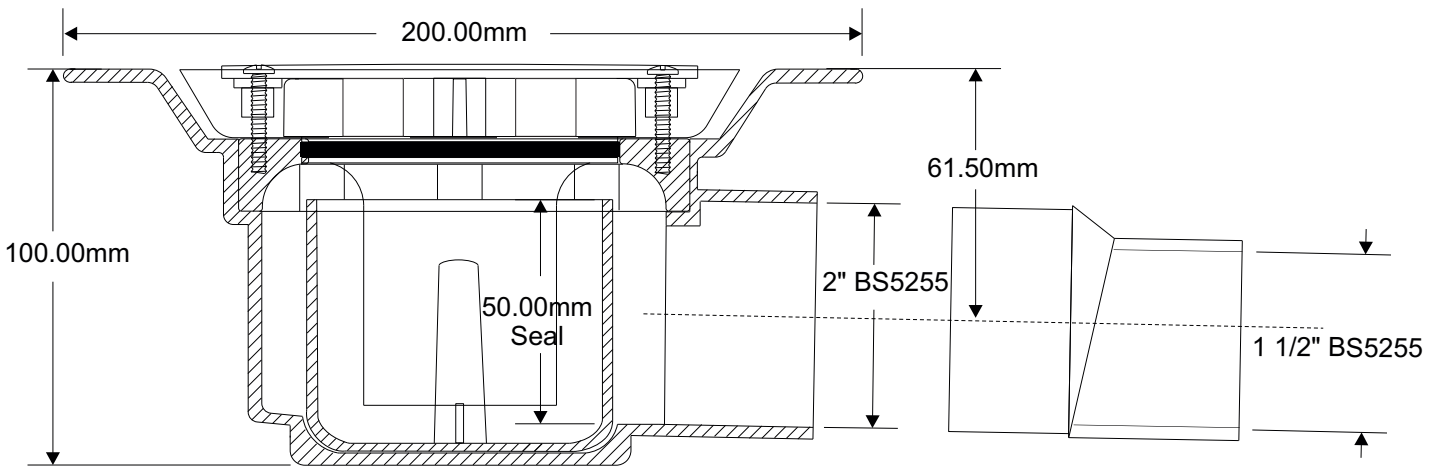



OTL TSG 2 WH / BLK / SS

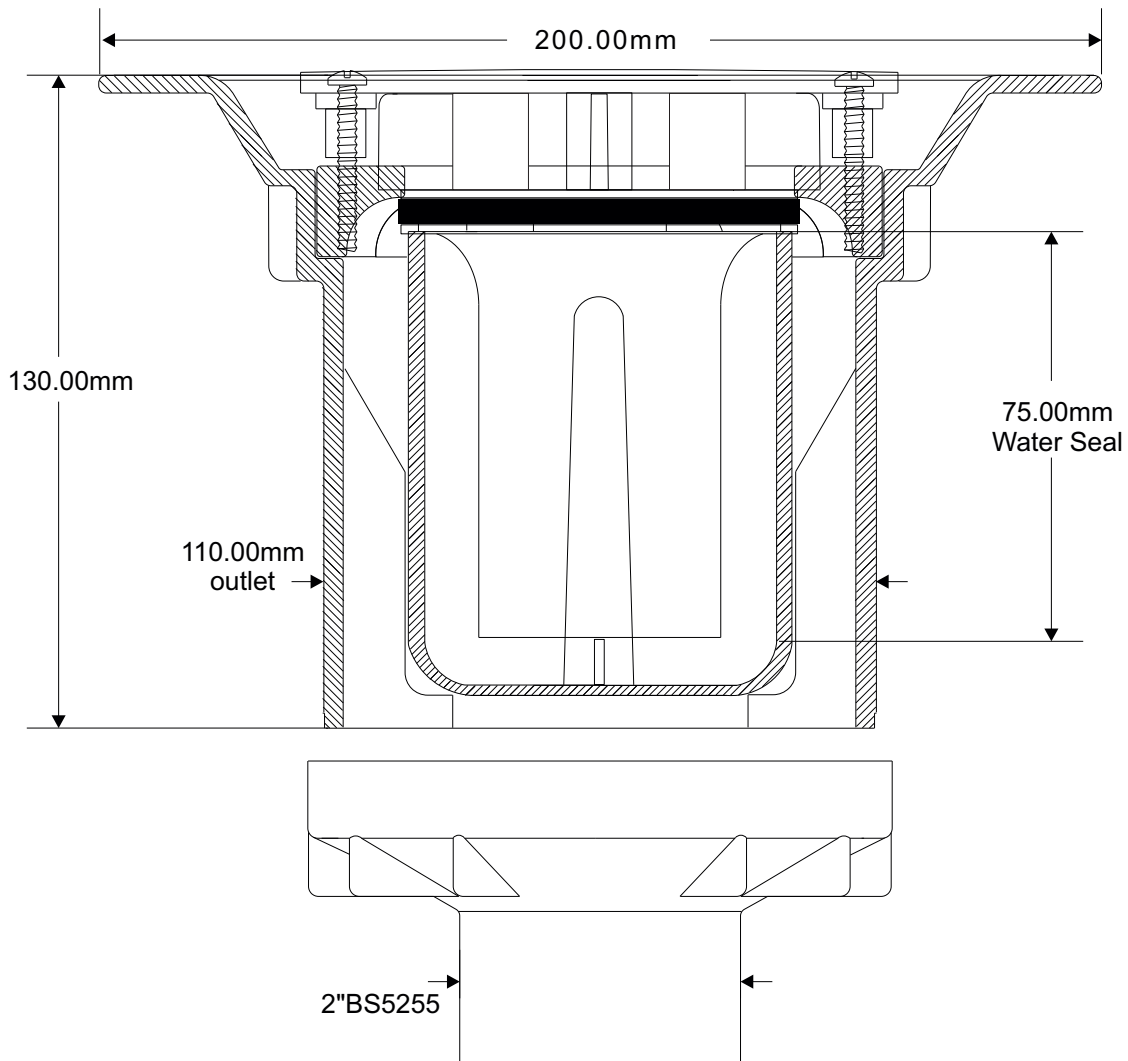



Untrapped Gully
Must be used with a pump

OTL USG 1 WH / BLK / SS

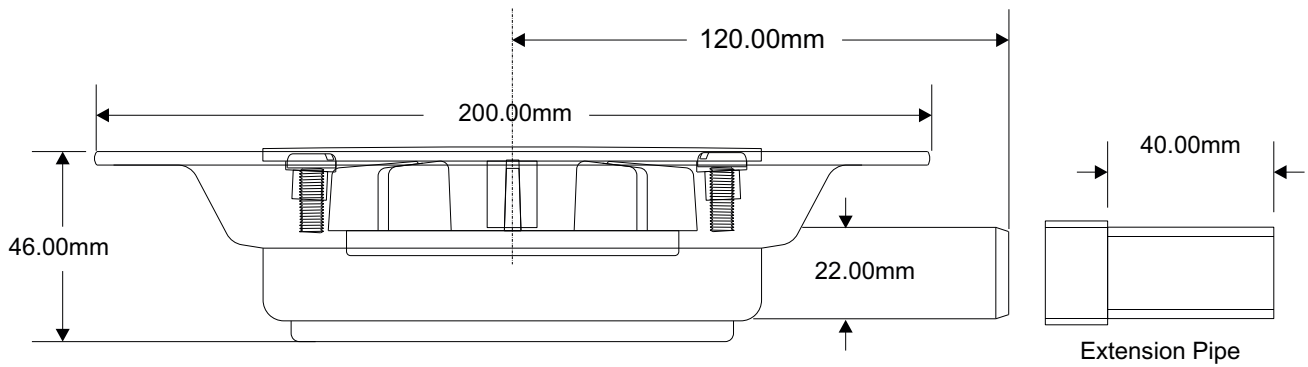

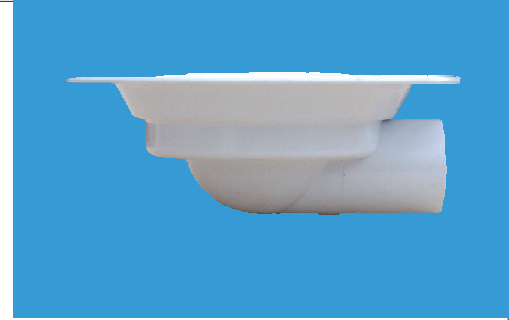

Untrapped Gully

OTL USG 3 WH / BLK / SS

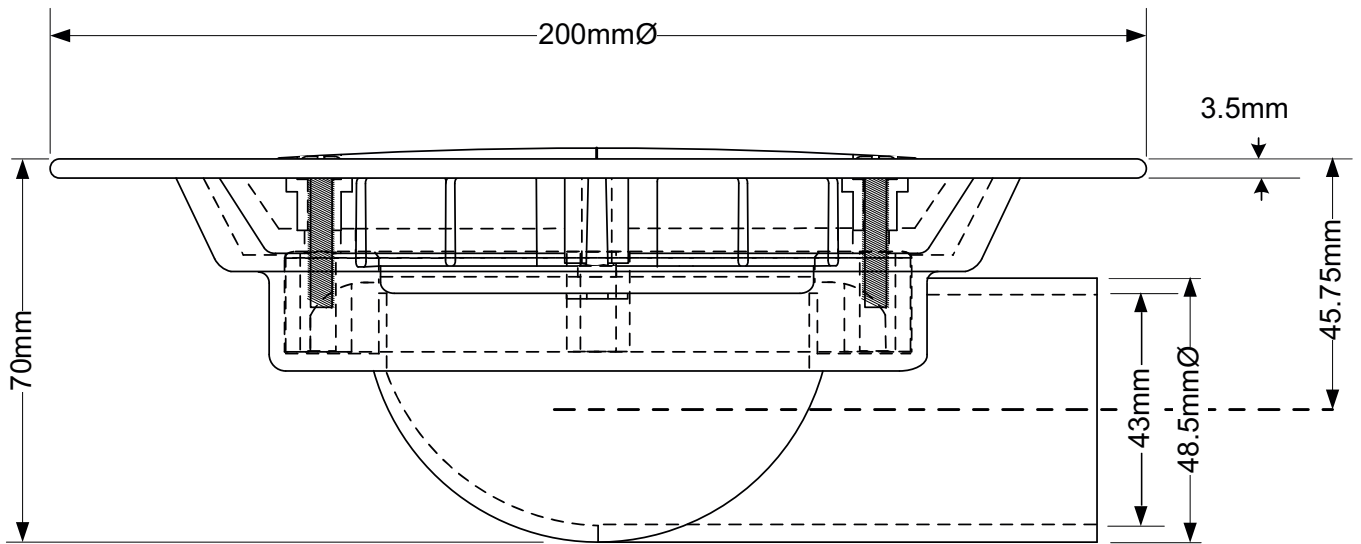

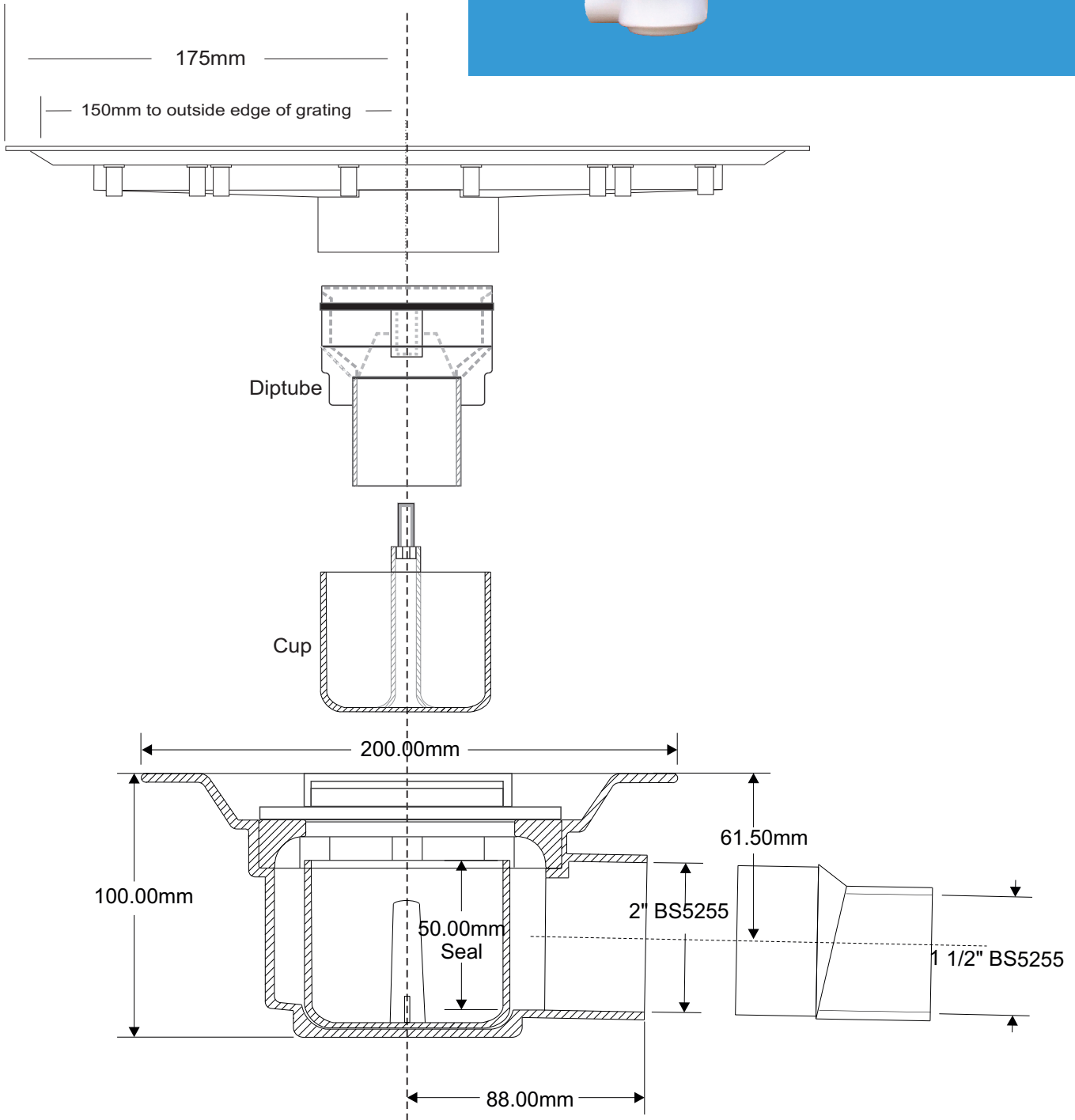

OTL Ref	Grating Length	Main Channel Length
OTL LIN 300	300mm	350mm
OTL LIN 700	700mm	750mm
OTL LIN 800	800mm	850mm
OTL LIN 900	900mm	950mm
OTL LIN 100	1000mm	1050mm

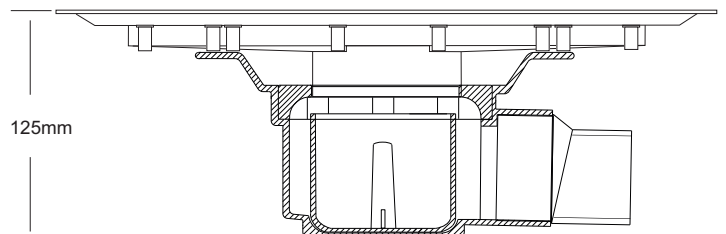

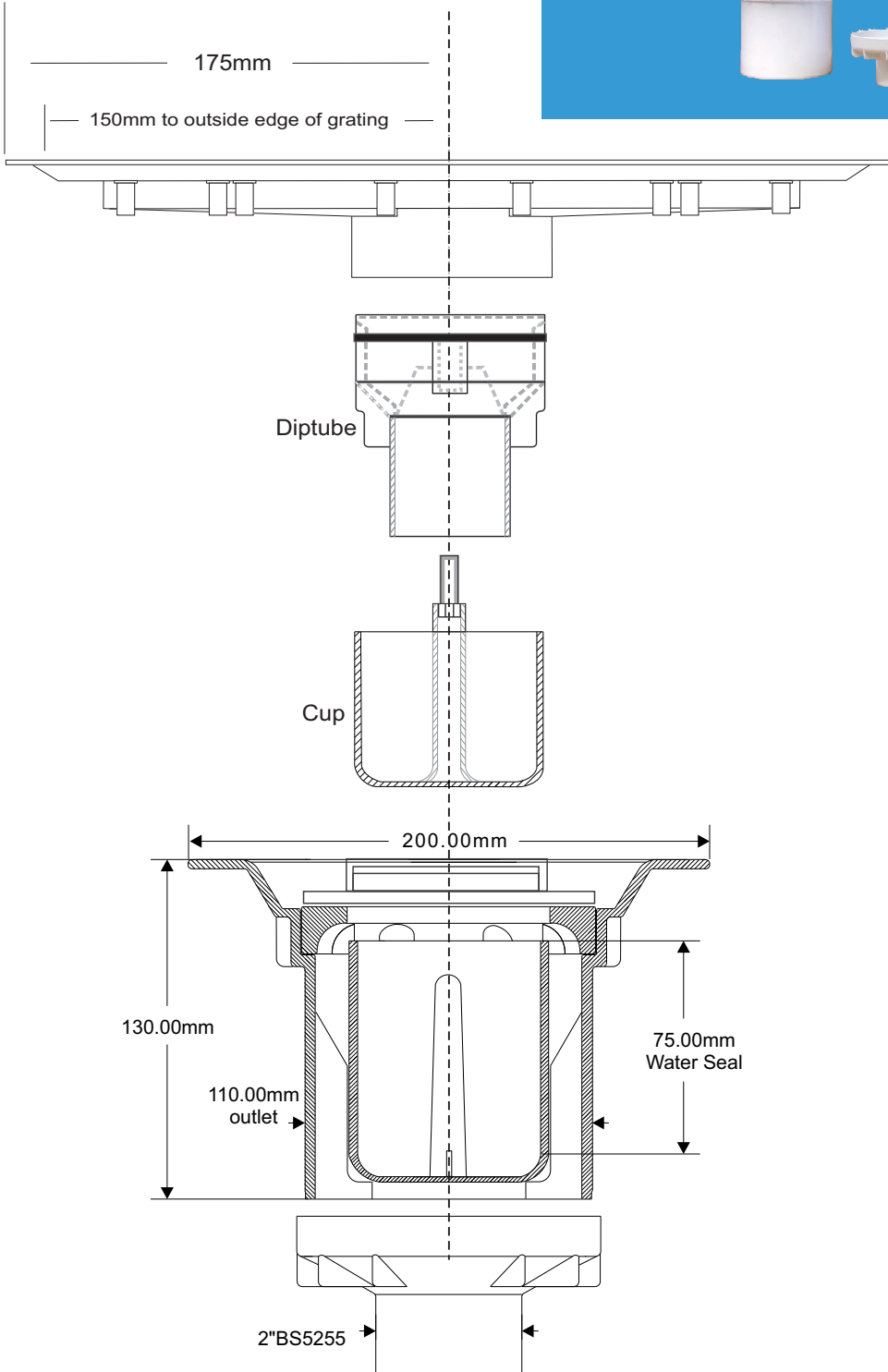

OTL Ref	Grating Length	Main Channel Length
OTL LIN 300	300mm	350mm
OTL LIN 700	700mm	750mm
OTL LIN 800	800mm	850mm
OTL LIN 900	900mm	950mm
OTL LIN 100	1000mm	1050mm

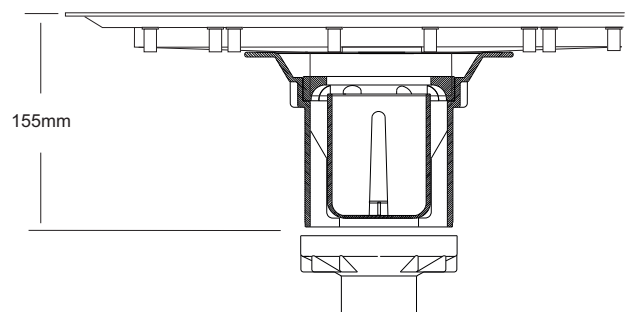

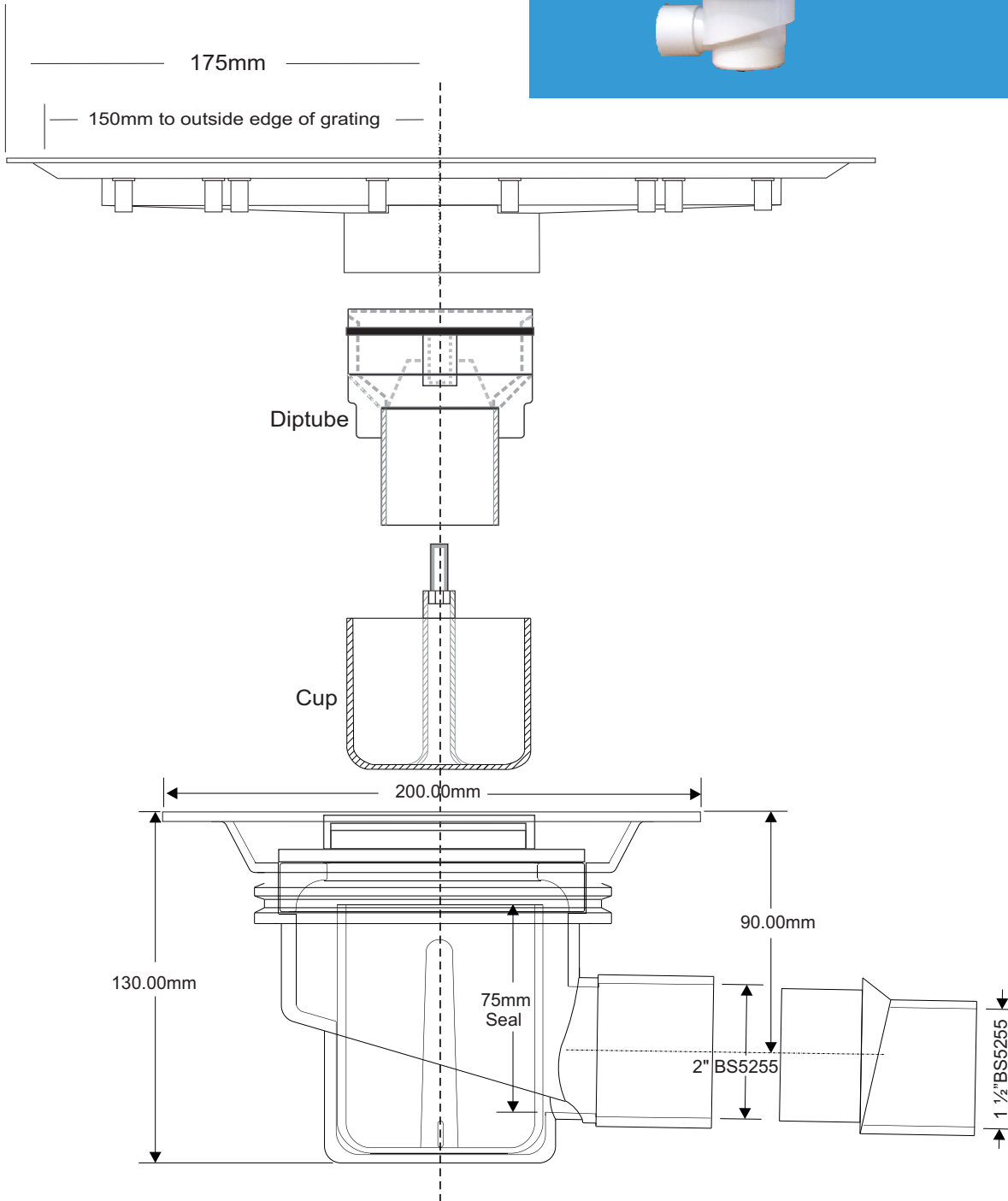

OTL Ref	Grating Length	Main Channel Length
OTL LIN 300	300mm	350mm
OTL LIN 700	700mm	750mm
OTL LIN 800	800mm	850mm
OTL LIN 900	900mm	950mm
OTL LIN 100	1000mm	1050mm

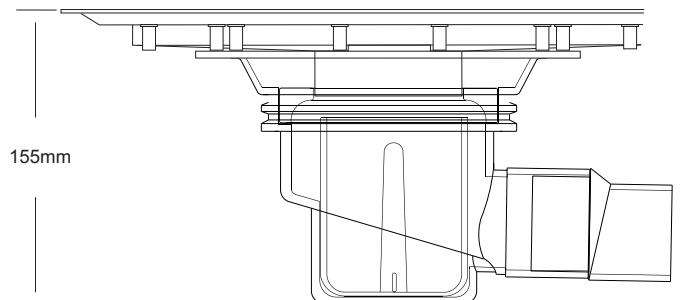

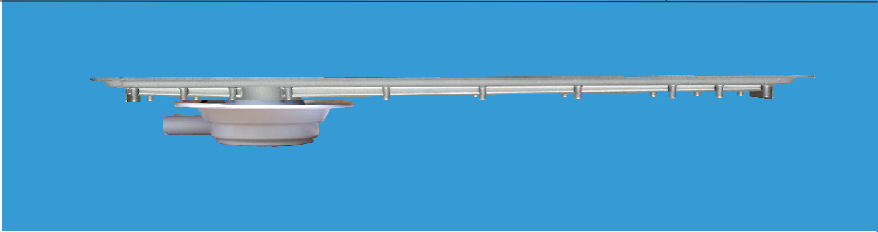

**Untrapped Gully
Must be used with a pump**

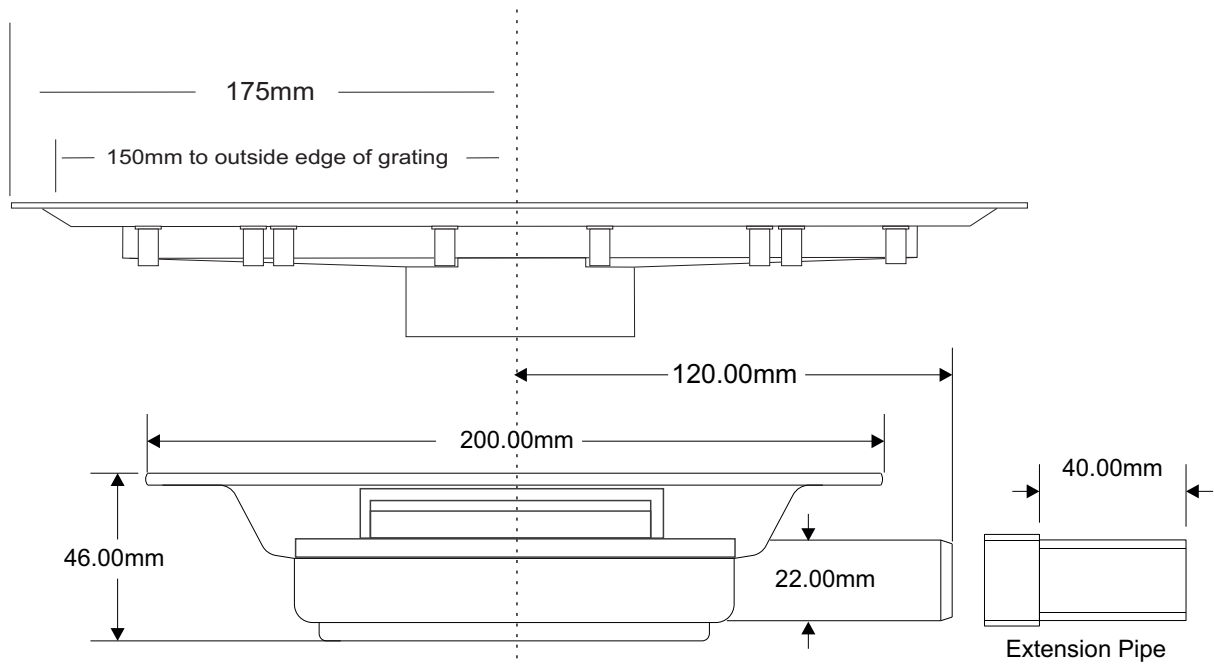

OTL Ref	Grating Length	Main Channel Length
OTL LIN 300	300mm	350mm
OTL LIN 700	700mm	750mm
OTL LIN 800	800mm	850mm
OTL LIN 900	900mm	950mm
OTL LIN 100	1000mm	1050mm

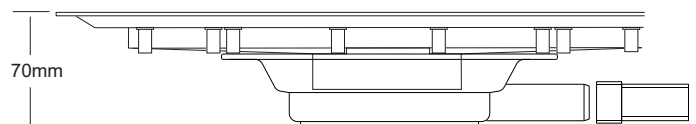

Untrapped Gully

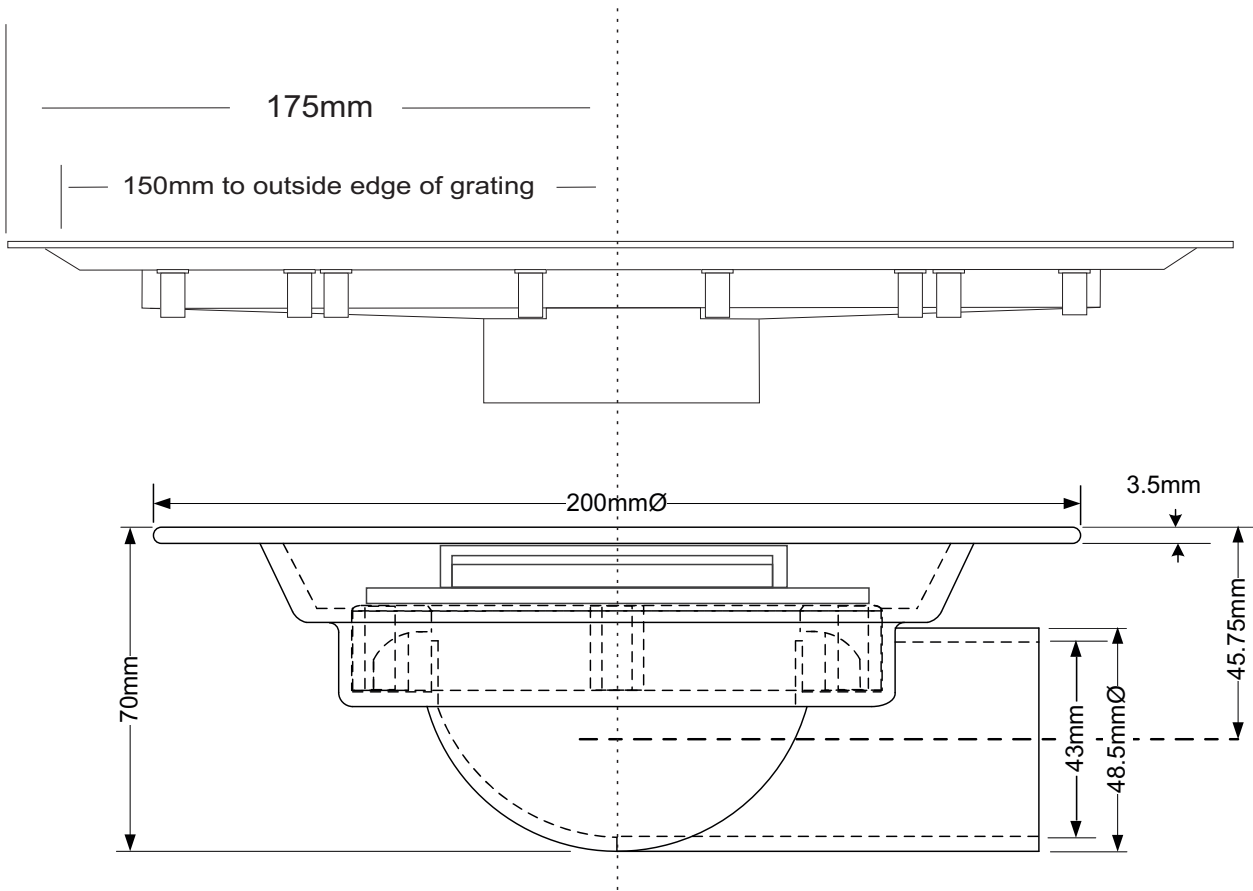
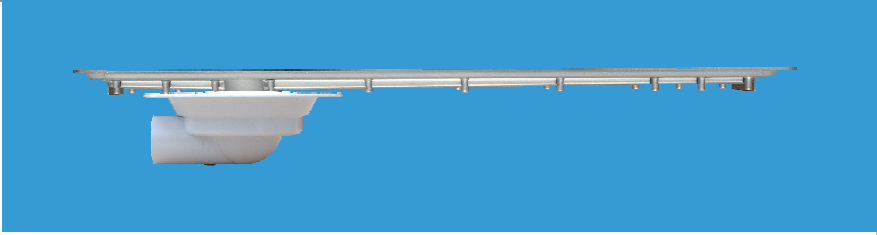

OTL Ref	Grating Length	Main Channel Length
OTL LIN 300	300mm	350mm
OTL LIN 700	700mm	750mm
OTL LIN 800	800mm	850mm
OTL LIN 900	900mm	950mm
OTL LIN 100	1000mm	1050mm

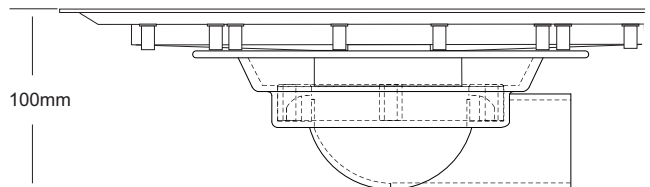

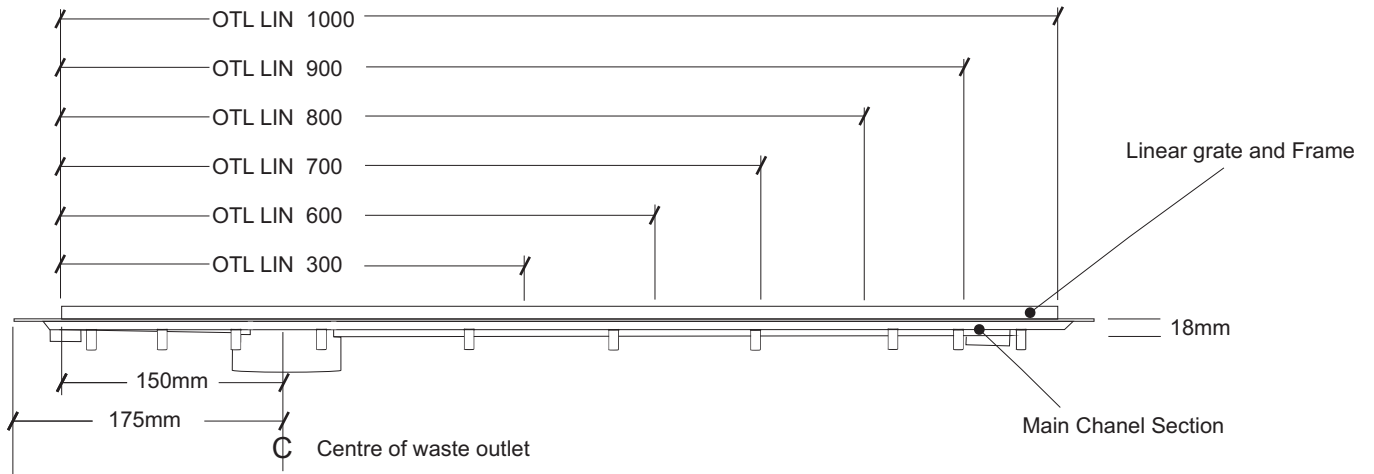

Grating Support

The Grating Support can be adjusted in height to suit any thickness of tile

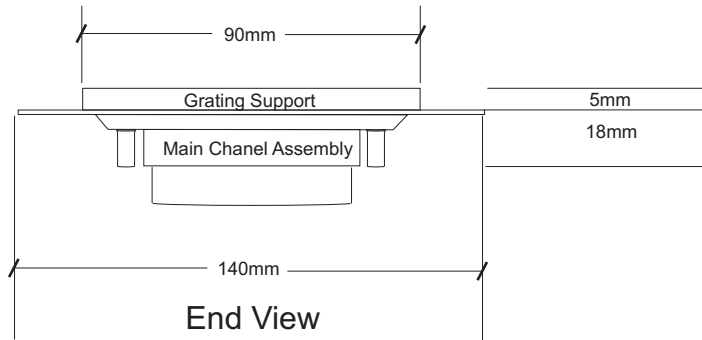

Please Note: The Main Channel Assembly is 50mm longer than the Grating Length

OTL Ref	Grating Length	Main Channel Length
OTL LIN 300	300mm	350mm
OTL LIN 600	600mm	650mm
OTL LIN 700	700mm	750mm
OTL LIN 800	800mm	850mm
OTL LIN 900	900mm	950mm
OTL LIN 100	1000mm	1050mm

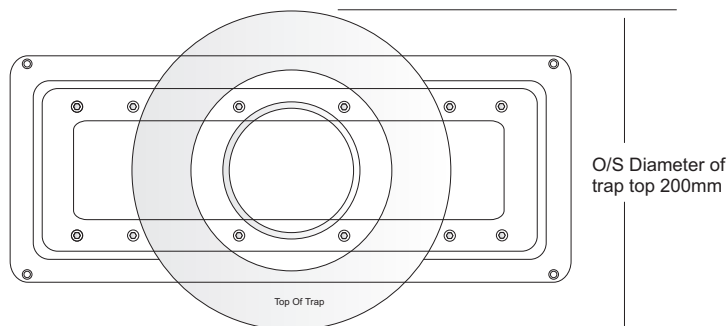

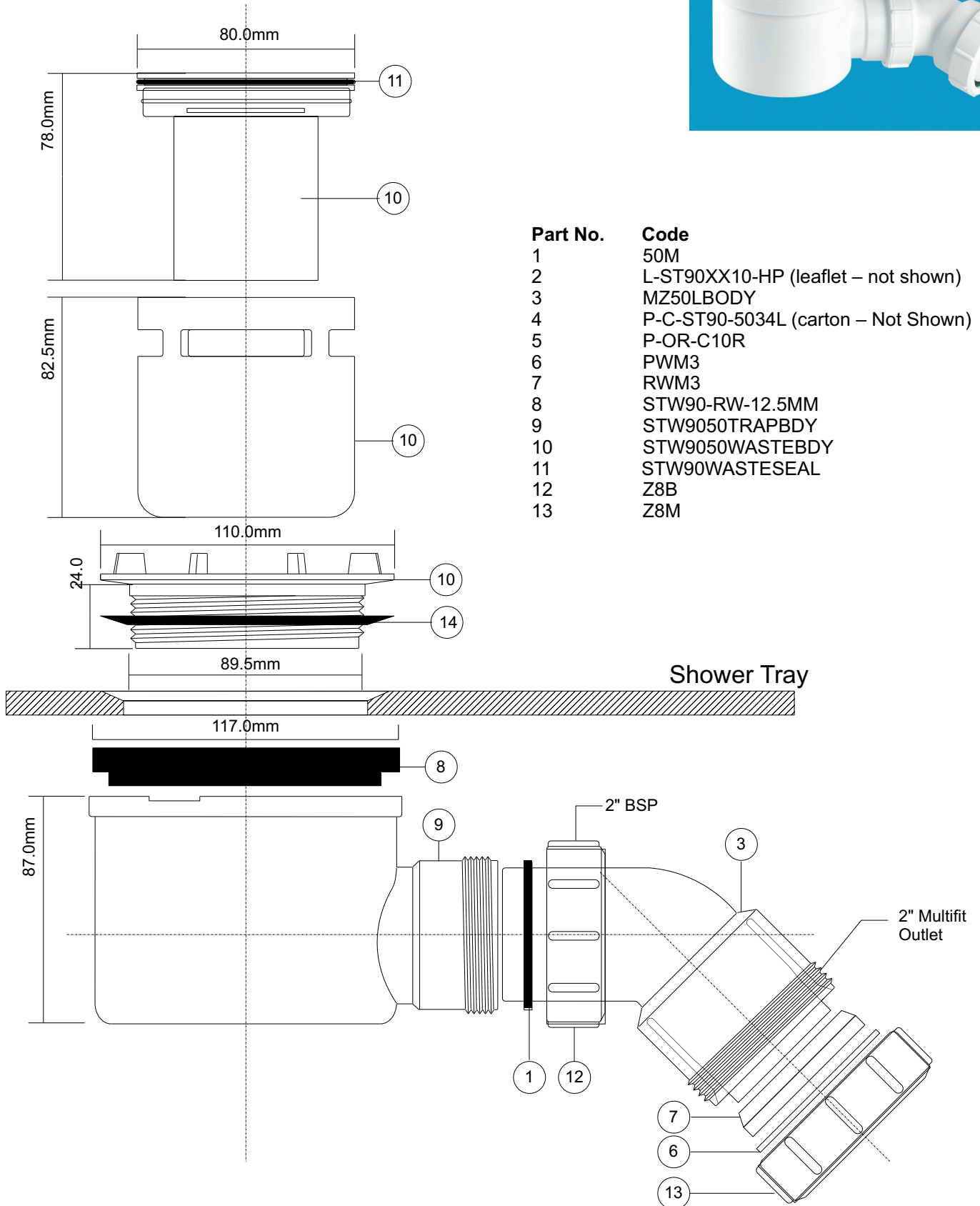

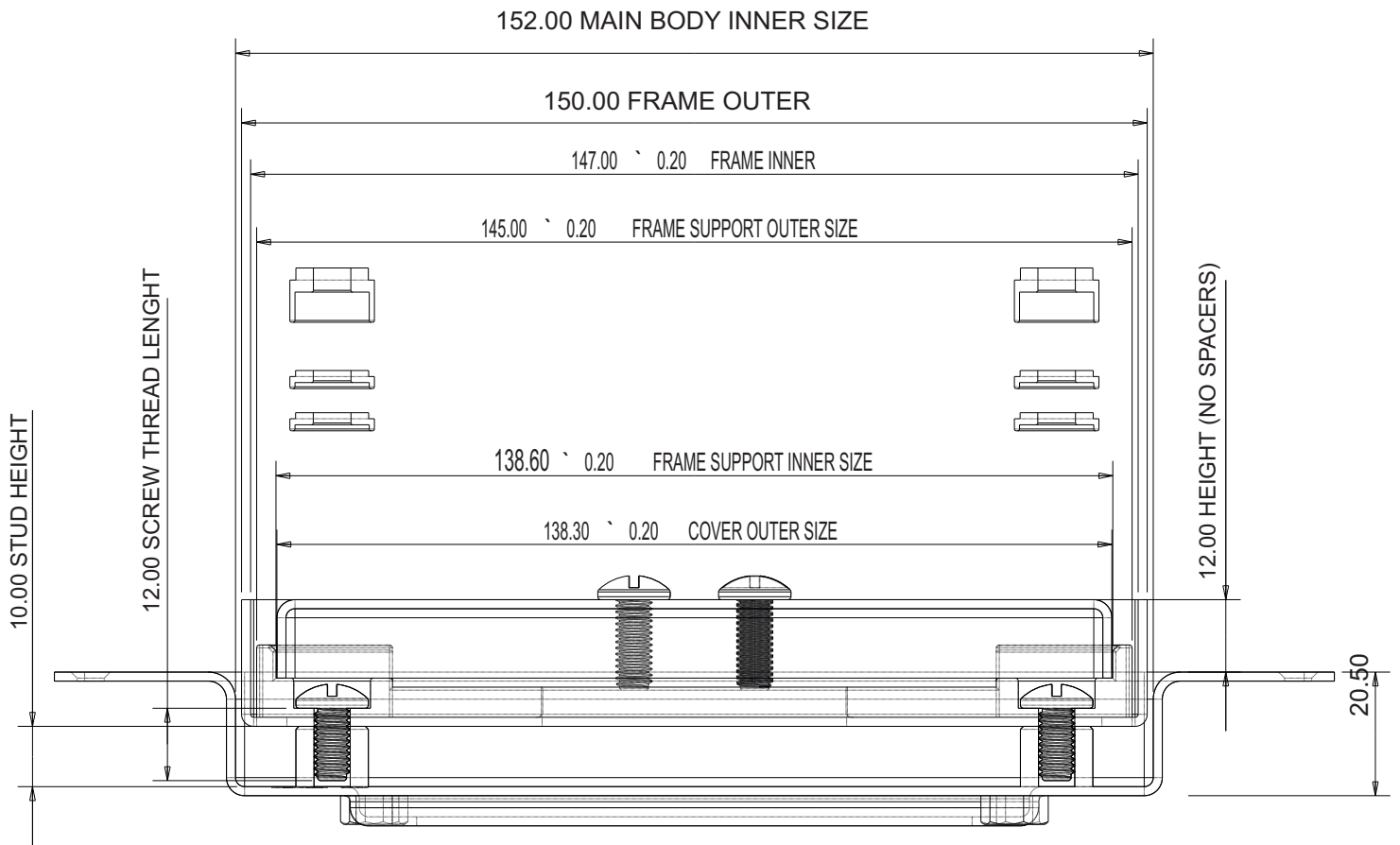
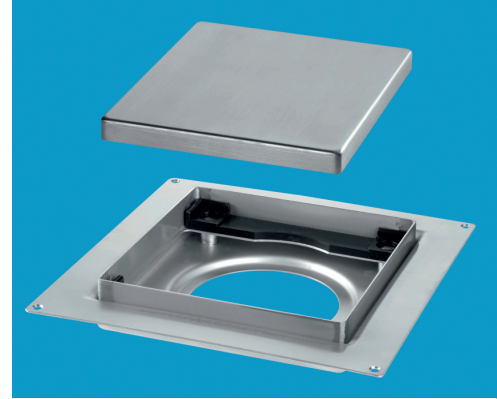

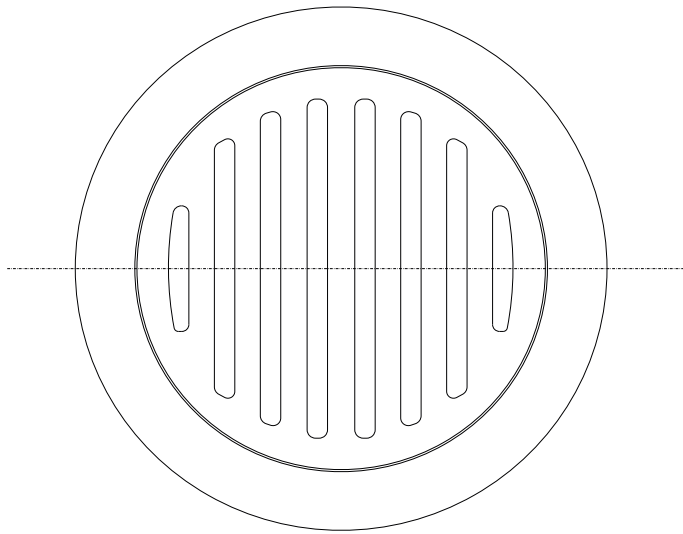

Part No.	Material
1	Stainless Steel
2	Nitrile Rubber
3	Stainless Steel
4	Nitrile Rubber
5	Polypropylene

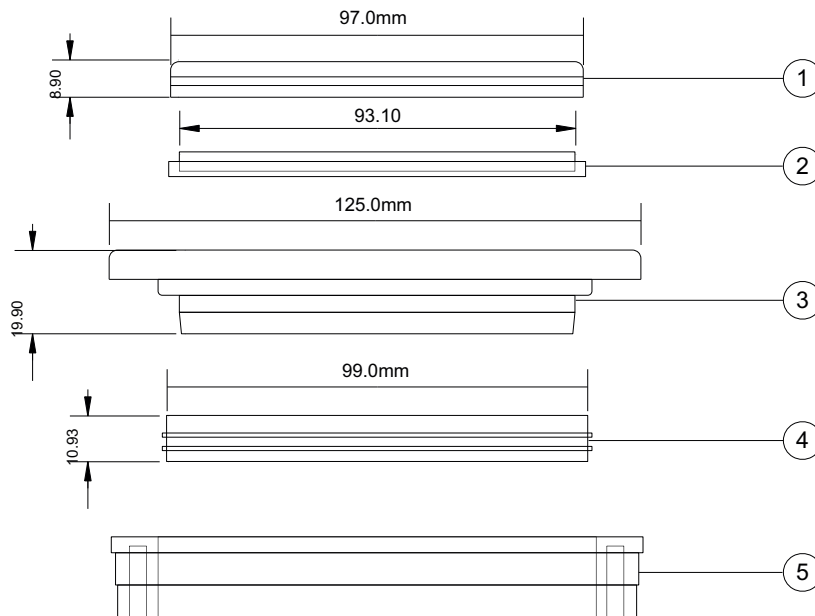

OTL TSGCG50

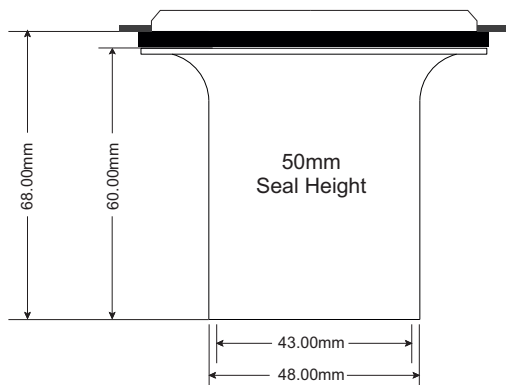

OTL TSGCG75

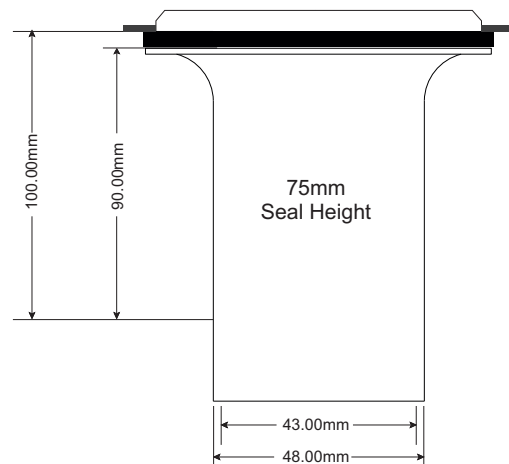

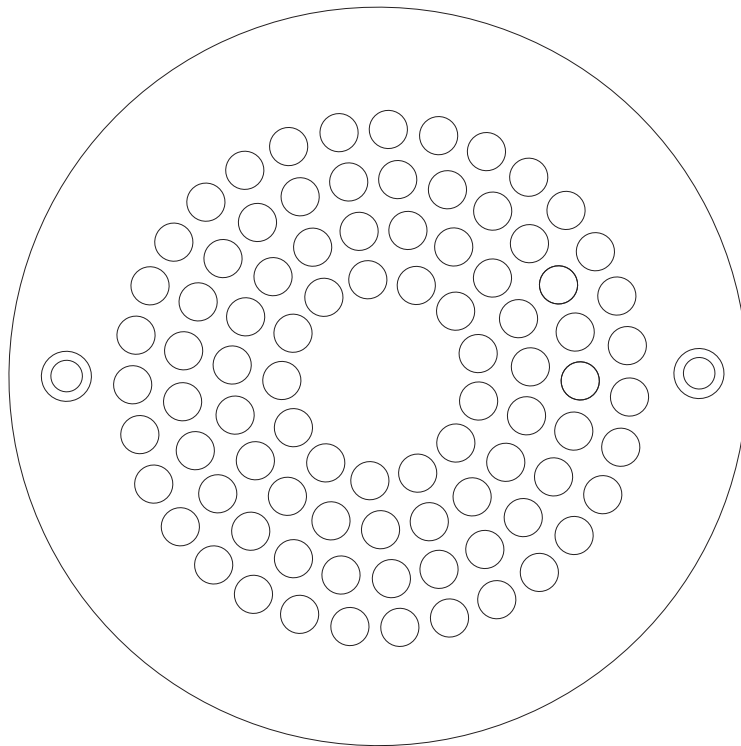

5mm 