

# CONVERTING INDUSTRIES



Advanced  
Web Solutions



# Converting: The NDC Technologies Advantage

## Measurements and controls for the coating and laminating processes

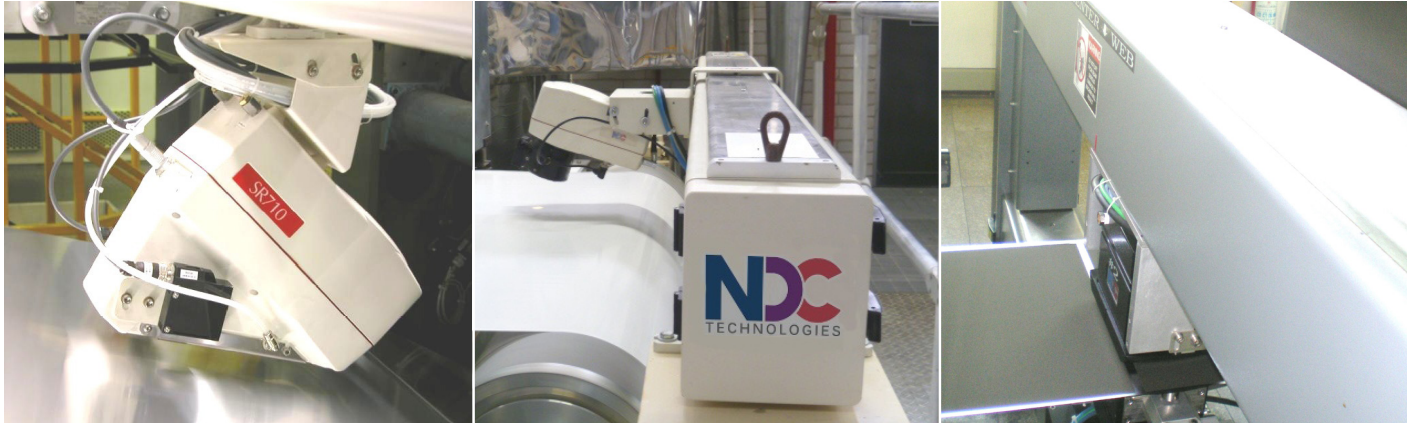

- ▶ Abrasives
- ▶ Adhesive Coating
- ▶ Coil & Foil Coating
- ▶ Extrusion Coating
- ▶ Lamination
- ▶ Paper Coating
- ▶ Specialty Coating
- ▶ Textile Coating

**The converting industry** includes a wide range of applications and processes, each with different measurement and control requirements. This includes single coater stations up through complex, multi-scanner tandem extrusion lamination lines with advanced web gauging measurements and controls.

NDC's family of web gauging systems are uniquely positioned to address the challenges of the converting industry. With nine distinct measurement technologies, three scanning frame designs and two system platforms, NDC can provide the exact web gauging configuration for each process. Add to that NDC's applications expertise and global service support and the result is optimum product quality and a fast return on investment (ROI).

# NDC's Measurement Excellence

## Measurement techniques for the converting processes

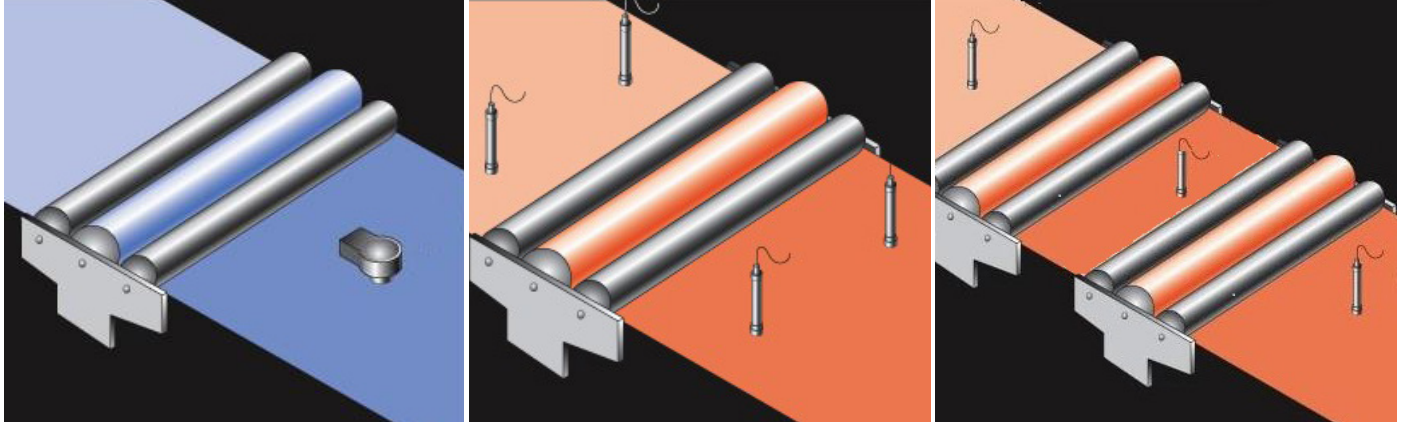

► **Direct Selective Measurement:**

A single infrared sensor can be used where coat weight measurement is required. NDC's infrared sensor measures just the coating layer directly and independently from the substrate layer with its selective measurement technology.

► **Combination Measurement:**

Two sensors are placed on a single scanner after the coater. The selective sensor measures the coating directly while the basis weight sensor measures total mass. The basis weight of the substrate is determined by subtraction.

► **Differential or Subtractive Coat Weight Measurement:**

Two sensors are used where the first sensor measures the substrate and the second sensor measures the total weight (coat + substrate). The coat weight is calculated by subtracting these two measurements.

► **"Same Spot" Measurement:**

Some substrates such as paper exhibit significant formation or weight variations. Same Spot Measurement assures that the sensors of multi-scanner systems are synchronized so that each sensor traverses precisely along the same path on the web. This eliminates any substrate variability from affecting the coat weight measurement. This feature can also ensure same-spot measurement throughout line speed transitions.

► **"True Net Coat" Measurement:**

In addition to Same Spot, NDC's differential measurement system can also employ "True Net Coat". The True Net Coat model allows for both sensors (total and base) to be calibrated against the coat response curve which enables a far more accurate net coat calculation.

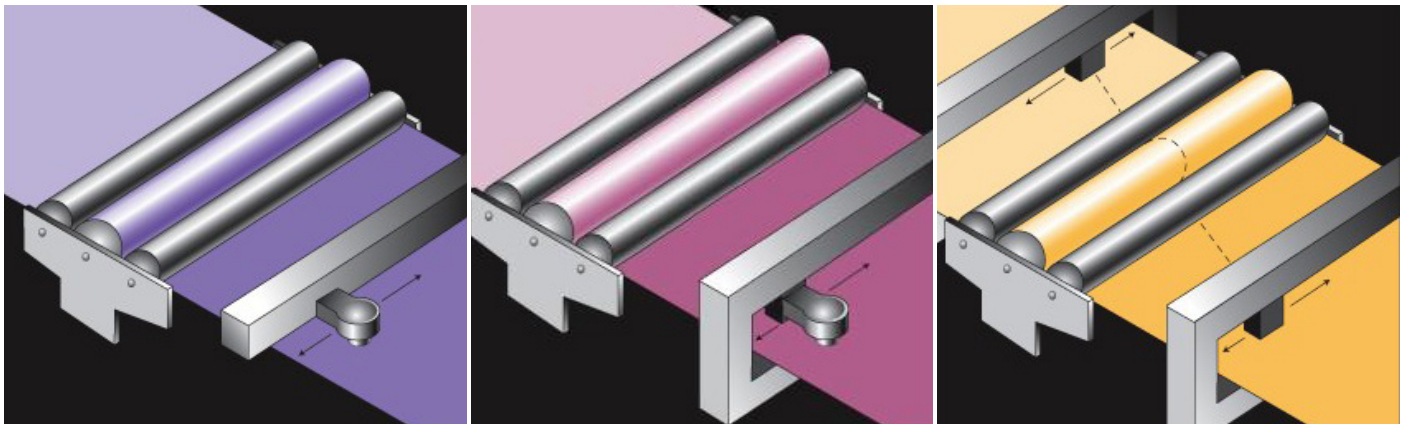

# Company overview

Combining industry-best performance and reliability with a global support structure

NDC Technologies, based in Irwindale California, develops and manufactures measurement and control equipment for a wide range of process industries. The company also manufactures in Essex, UK, Dayton, Ohio and has a Technical Center of Excellence in Loncin, Belgium with direct sales and support operations in China, Japan, Germany, France, Italy and Brazil.

Our global client base consists of some of the world's most successful companies who rely on NDC to ensure that their product performance, process yield and quality meet the stringent standards demanded by their customers.

**NDC comprises four divisions:**

**Web Solutions** service the converting, extrusion, calendering and nonwovens industries, providing real-time measurement of key product parameters such as product thickness, coating thickness & basis weight.

**Sensors** service the food, chemical, pharmaceutical, mineral, bulk materials and tobacco industries with on-line and at-line measurements system for constituents such as moisture, fat and protein content.

**Metals** service the steel and non-ferrous metals industry, delivering rugged measurements systems for key parameters such as thickness, width, flatness, edge shape and metals coatings.

**Laser and Ultrasonics** produce non-contact gauges for the on-line and off-line measurement of diameter and ovality, wall thickness and eccentricity, length and speed, and other dimensional monitoring of products in the wire and cable, fiber optics, pipe and tube, building, nonwovens, paper, plastic, and metals industries.

NDC is part of Spectris plc, the leading supplier of productivity-enhancing instrumentation and controls.



NDC is represented in over 60 countries worldwide. ISO9001:2008 [www.NDC.com](http://www.NDC.com)



**NDC Technologies Inc.**  
Tel: +1 626 960 3300  
Email: [info@ndc.com](mailto:info@ndc.com)

**NDC Technologies sa**  
Tel: +32 4 239 90 10  
Email: [sales@ndcinfraed.be](mailto:sales@ndcinfraed.be)

**NDC China**  
Tel: +86 20 2887 3860  
Email: [info@ndcinfraed.com.cn](mailto:info@ndcinfraed.com.cn)

**NDC Germany**  
Tel: +49 1801 977112  
Email: [ndcgermany@ndc.com](mailto:ndcgermany@ndc.com)

**NDC Singapore**  
Tel: +65 91994120  
Email: [apacsales@ndc.com](mailto:apacsales@ndc.com)

**NDC Technologies Ltd**  
Tel: +44 1621 852244  
Email: [enquiries@ndc.com](mailto:enquiries@ndc.com)

**NDC Beta LaserMike**  
Tel: +1 937 233 9953  
Email: [sales@betalasermike.com](mailto:sales@betalasermike.com)

**NDC Japan**  
Tel: +81 3 3255 8157  
Email: [ndcjapan@ndc.com](mailto:ndcjapan@ndc.com)

**NDC Italy**  
Tel: +39 0331 454 207  
Email: [ndcitaly@ndc.com](mailto:ndcitaly@ndc.com)

**NDC India**  
Tel: +91 9890800697  
Email: [ndcindia@ndc.com](mailto:ndcindia@ndc.com)

In line with its policy of continuous improvement, NDC reserves the right to revise or replace its products or services without prior notice. The information contained in this document may not represent the latest specification and is for indicative purposes only.

Document Number: AN-112-15514-02-2014-10  
Date of Issue: October 2014  
© NDC 2014



# Accurate, Reliable Measurement

## Application-matched sensors

that produce superior results from your process

NDC710S & FS710S



► **NDC710S Infrared**

The NDC710S backscatter sensor provides high-resolution, accurate coat weight, laminate and moisture measurement for paper and other substrates. Selective infrared technologies provide direct coat weight measurements that can discriminate up to 6 components in coatings without the need for additional scanners and sensors.

► **FS710S Infrared**

The FS710S measures moisture in both paper and board. Its forward-scatter optical configuration, combined with carefully specified filters ensures optimum sensitivity and accuracy across a wide range of product structures.

► **SR710S Infrared**

The SR710S reflectance gauge is specifically designed to accurately measure thin, clear coatings on metal foils, metalized papers and plastics. Its unique optical configuration minimizes any interference effects, while its use of mid-infrared absorption allows the thinnest of coatings, such as lube layers on can stock, to be easily and accurately measured.

► **XRB X-Ray Backscatter**

NDC's X-ray single-sided backscatter (XRB) sensor offers unsurpassed measurement range and low installation costs. It combines good measurement performance with minimal issues related to licensing costs.

XRT



► **XRT X-Ray Transmission**

NDC's X-ray transmission (XRT) sensor offers excellent measurement precision and CD resolution. Its variable energy range provides superb flexibility across a variety of applications, including high tolerance to product flutter. Like the XRB, it shares minimal issues related to licensing costs or administration.

► **GBS Gamma Backscatter**

The Gamma Backscatter sensor family (GBS) provides cost-effective measurement in a compact, single-sided form factor. The sensor combines an integrated source and detector for measuring either the thickness or weight of a product from one side of the sheet. Its compact size allows measurements to be taken from parts of the process that may be inaccessible to conventional sensors.

GBS



► **Beta Transmission**

NDC's Model 300 beta transmission sensors provide accurate, on-line measurement of product's total thickness or basis weight. These sensors feature a high-efficiency detection system and are selected with optimum source activity for each application.

SR710S



XRB

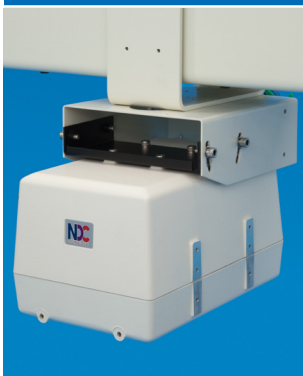

Beta



# Proven, Capable Solutions

## NDC applications for the converting industries

...the difference is experience

### Same-Spot Measurement

Precisely coordinates the sampling and data collection of substrate and coated product gauges to provide accurate, responsive coat weight measurement by directly linking scanning speed to the process line speed. Accurate measurement is maintained throughout line speed changes.

### FastStart

Fast Start provides an early indication of coat weight during start-up and product changes and is valuable for multi scanner measurement configurations. Once the process lag-time between scanners has passed, the system automatically transfers scanner timing to provide Same Spot functionality.

### Specialty Coat Weight Measurement Options

**Gap Exclusion** software measures the coat weight of 'patch coatings' and excludes measuring the uncoated machine direction and cross direction areas between each coating deposition.

**Pattern Recognition** software measures the coat weight of 'stripe coatings' and ignores the machine direction gaps between the applications.

### Explosion-Proof and Harsh-Environment Equipment Options

Certain scanners & sensors available in Class 1, Division 1, Group C & D approved designs. ATEX-approved designs are available for certain products. Contact an NDC representative for more information.

### Solvent-Based Coating Measurement

For processes with consistent solids ratio in the wet coating, a final coat weight profile determination may be made based on measurement of the wet coating, prior to drying.

#### Extrusion, Coating and Lamination for Industrial Material Applications

Single coating station

Tandem coating station (up to 3 stations)

#### Extrusion Coating and Lamination for Packaging Materials Applications

Single coating station

- Flexible packaging

Tandem coating stations (up to 4 stations)

- Liquid packaging (aseptic)

- Flexible packaging

#### Textile Coating

PUR

Latex

Silicon, stain resistant coatings

PVC

#### Coil and Metal Foil Coating

Wax, oil, chromate, polymer, lacquer on steel

Adhesive, wax, oil, lacquer on copper

Adhesive, polymer, wax, oil, lacquer on aluminum

#### Specialty Coating

Lithium ion and other types of battery coating

Dry photoresist coating

Optical films including PDP and LCD

Window and glazing films

Magnetic media (Fe<sub>2</sub>O<sub>3</sub> coating)

#### Paper Coating

NCR (carbonless) coating

Thermal coating

Adhesive coating (label stock)

PVDC coating

Silicon coating (release papers)

#### Polymer Film Coating

Adhesive labels, tapes and dermal patches

Laminating pouches and protective films

PVDC

#### Abrasives Manufacturers

Makers

Sizers

Up to 5 scanners and 6 sensors