

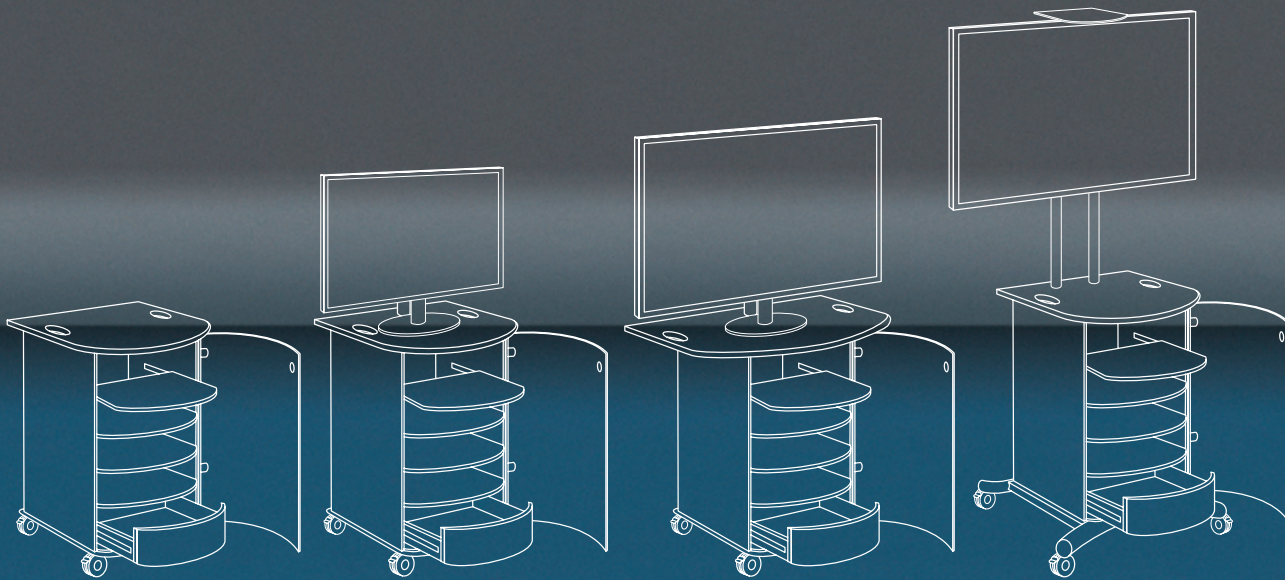

**MiTRE**<sup>®</sup>

Audio Visual  
Furniture





Utilising our many years of experience in supplying the Audio Visual and Office Products markets, we are delighted to introduce our new refreshing range of audio visual furniture which is certain to enhance a professional presentation environment.

Mitre® products feature a contemporary curved smoked glass front door and a vented rear access plates. Neutral light grey cabinet designs are complimented by a choice of three attractive coloured top and base platforms.

## A stunning new range of audio visual furniture

All Mitre® units are made to order

Standard lead time is 4-7 working days

All prices shown are Suggested Retail Prices (SRP) and include free UK mainland delivery (excluding Scottish highlands)

All prices are net excluding VAT

Full terms and conditions of sale available on request





## Multi-media Presenter

Registered Design No. 4029764

Contemporary cabinet with 3 height adjustable shelves and a sliding top shelf which makes this unit ideal for multi-media projector presentations.

See pages 4-5



## Presenter

Registered Design No. 4029765

Stylish LCD cabinet that has a mounting bracket designed to secure screens up to 50" when used in conjunction with the manufacturers stand, ideal for smaller audiences.

See pages 6-7



## Presenter XL

Registered Design No. 4029766

The XL cabinet is ideal for larger audiences as it benefits from a wider top platform that accepts screens up to 65" secured to the support bracket when used with the manufacturers stand.

See pages 8-9



## Conference

Registered Design No. 4029763

This modern Conference unit offers a professional platform for conferences and meetings, whilst also being ideal for use in break out and reception areas.

See pages 10-11

# MITRE®

## Multi-media

Registered Design No. 4029764

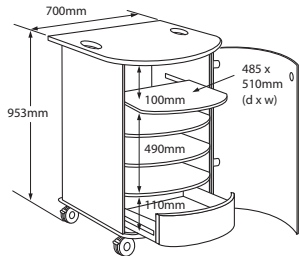

Lockable front and rear access offers a secure space to house all your multi-media and projection equipment.

Top platform measures a generous 700mm in width with in-built contoured handles for ease of manoeuvrability.

A practical sliding draw is positioned at the base of the unit providing an ideal space for housing accessories such as remote controls, DVD's or cabling.

Optional 19" rack mount accessory available with 23 hole pitch positions and fixings.



### Graphite

Product Code SRP  
VIP90G £783



### Aqua

Product Code SRP  
VIP90B £783



### Ruby

Product Code SRP  
VIP90R £783



### 19" rack mount

Product Code SRP  
VIP103 £59



### Cabinet features

Light grey cabinets with graphite grey, ruby red or aqua blue top and base.

5mm curved smoked lockable tempered safety glass doors

Heavy duty steel lockable access plate to rear, measuring 450 x 160mm (h x w) is vented to assist with temperature control

Locks for front and rear access are keyed alike

4 height adjustable shelves, sliding top shelf and a practical sliding draw at base

Durable 100mm Tente® twin wheeled, precision ball bearing castors, 2 locking

Maximum spread load capacity recommended at 150kgs



Locking rear easy access plate



Optional 19" rack mounting kit  
Registered Design No. 4029762



# MITRE® Presenter

Registered Design No. 4029765

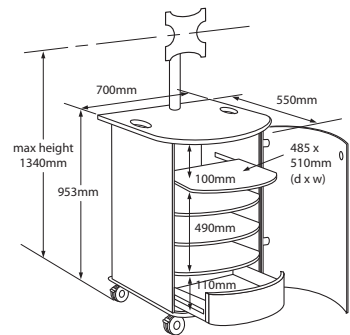

The Mitre® Presenter features an additional rear support bracket which is designed to secure screens up to 50° allowing it to be manoeuvred securely from room to room.

Generous 700mm wide top platform with in-built contoured handles for ease of manoeuvrability.

The cabinet houses 4 shelves, 3 height adjustable and 1 sliding to hold your multi-media equipment and a draw providing storage for accessories, such as remote controls, DVD's or cabling.

Optional 19" rack mount available with 23 hole positions and fixings.

### VESA support bracket

The support bracket is height adjustable between 220-500mm and also acts as a theft deterrent.

Robust steel bracket supports VESA hole configurations of 75 x 75mm, 100 x 100mm, 200 x 100mm, 200 x 200mm .

Additional attachment plates are supplied to secure sets with larger VESA patterns up to 400 x 400mm.

Recommended maximum set weight of 45kgs.



### Graphite

Product Code  
VIP91G

SRP  
£912

### Aqua

Product Code  
VIP91B

SRP  
£912

### Ruby

Product Code  
VIP91R

SRP  
£912

### 19" rack mount

Product Code  
VIP103

SRP  
£59



### Cabinet features

Light grey cabinets with graphite grey, ruby red or aqua blue top and base.

5mm curved smoked lockable tempered safety glass doors

Heavy duty steel lockable access plate to rear, measuring 450 x 160mm (h x w) is vented to assist with temperature control

Locks for front and rear access are keyed alike

4 height adjustable shelves, sliding top shelf and a practical sliding draw at base

Durable 100mm Tente® twin wheeled, precision ball bearing castors, 2 locking

Maximum spread load capacity recommended at 150kgs



Infra-red compatible glass door



Locking rear easy access plate



# MITRE® Presenter XL

Registered Design No. 4029766

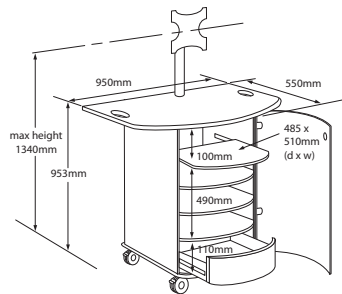

The 950mm wide XL top platform has in-built contoured handles and is spacious enough to take larger screens up to 65".

The cabinet houses 4 shelves, 3 height adjustable and 1 sliding to hold your multi-media equipment and a draw providing storage for accessories, such as remote controls, DVD's or cabling.

Optional 19" rack mount available with 23 hole positions and fixings.

### VESA support bracket

The support bracket is height adjustable between 220-500mm and also acts as a theft deterrent.

Robust steel bracket supports VESA hole configurations of 75 x 75mm, 100 x 100mm, 200 x 100mm, 200 x 200mm .

Additional attachment plates are supplied to secure sets with larger VESA patterns up to 400 x 400mm.

Recommended maximum set weight of 45kgs.



### Graphite

Product Code SRP  
VIP92G £932



### Aqua

Product Code SRP  
VIP92B £932



### Ruby

Product Code SRP  
VIP92R £932



### 19" rack mount

Product Code SRP  
VIP103 £59



### Cabinet features

Light grey cabinets with graphite grey, ruby red or aqua blue top and base.

5mm curved smoked lockable tempered safety glass doors

Heavy duty steel lockable access plate to rear, measuring 450 x 160mm (h x w) is vented to assist with temperature control

Locks for front and rear access are keyed alike

4 height adjustable shelves, sliding top shelf and a practical sliding draw at base

Durable 100mm Tente® twin wheeled, precision ball bearing castors, 2 locking

Maximum spread load capacity recommended at 150kgs



Infra-red compatible glass door



Locking rear easy access plate



# MITRE<sup>®</sup> Conference

Registered Design No. 4029763

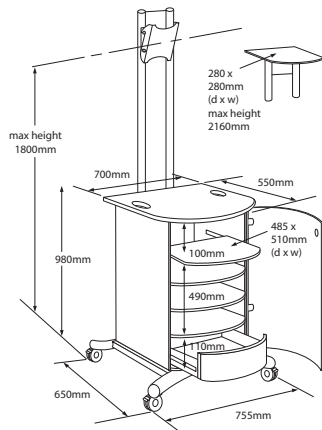

The cabinet of the Mitre<sup>®</sup> Conference is built into a sturdy steel stand, designed to secure screens up to 65" diagonal.

To the rear of the LCD column a full length vented cover allows easy access for cable installation.

An optional height adjustable video conference shelf that can be secured above the LCD screen to convert this module in to a truly professional video conferencing tool.

Optional 19" rack mount available with 23 hole positions and fixings.

### VESA support bracket

The height adjustable VESA compatible bracket allows for increments of 40mm up to a maximum of 800mm from the top of the cabinet to the centre of the bracket.

The bracket allows the set to tilt up to a 15° angle for optimal positioning.

Robust steel bracket supports VESA hole configurations of 75 x 75mm, 100 x 100mm, 200 x 100mm, 200 x 200mm .

Additional attachment plates are supplied to secure sets with larger VESA patterns up to 400 x 400mm.

Recommended maximum set weight of 45kgs.



### Graphite

Product Code SRP  
VIP93G £1160



### Aqua

Product Code SRP  
VIP93B £1160



### Ruby

Product Code SRP  
VIP93R £1160



### 19" rack mount

Product Code SRP  
VIP103 £59



### Video conferencing camera shelf

Product Code SRP  
VIP102 £125



### Cabinet features

Light grey cabinets with graphite grey, ruby red or aqua blue top and base.

5mm curved smoked lockable tempered safety glass doors

Full height, heavy duty steel access plate to rear which is vented to assist with temperature control

4 height adjustable shelves, sliding top shelf and a practical sliding draw at base

Durable 100mm Tente<sup>®</sup> twin wheeled, precision ball bearing castors, 2 locking

Maximum spread load capacity recommended at 150kgs



Easy cable access - with removable cover plate



VESA plate with tilt facility

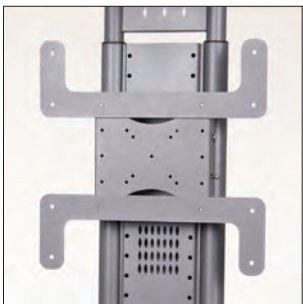

Large configuration VESA bracket included



Available from



**Metroplan Limited**

Lake District Business Park

Mint Bridge Road

Kendal, Cumbria

LA9 6NH, UK

**[info@metroplan.co.uk](mailto:info@metroplan.co.uk)**

**[www.metroplan.co.uk](http://www.metroplan.co.uk)**

For reseller pricing please contact

**[marketing@metroplan.co.uk](mailto:marketing@metroplan.co.uk)**

MAVC14