

// **New: Standard safety light grille**



High-Speed Doors

For optimised material flow and improved efficiency





Hörmann high-speed doors		4
Spiral door		6
HS 7030 PU	With PU insulating panels	8
Flexible high-speed doors		10
V 2715 SEL R	With tubular drive	12
V 5015 SEL	With SoftEdge and anti-crash	13
V 5030 SEL	With SoftEdge and anti-crash	14
V 6030 SEL	With SoftEdge and anti-crash	15
V 6020 TRL	Fully transparent	16
V 10008	Large door	17
Flexible high-speed door for special applications		
V 3015 RW	Rescue routes	19
Iso Speed Cold	Fast energy-saving door	20
V 4015 ISO L	Fresh and cold logistics	21
V 2515 FOOD L	Food industry	22
V 2012	Supermarket door	23
V 1401 ATEX	Explosion-proof	24
V 3015 CLEAN	Clean rooms	25
V 3009	Conveyor systems	26
H 3530	Horizontal door	27
Equipment, accessories		
	Standard equipment	28
	Controls	29
	Accessories	30
	Technical Data	33
	Programme overview	39



Texts for invitation of tenders and product drawings

With the Hörmann architects' programme, you can quickly and conveniently create individual texts for invitations of tenders in both GAEB and Word. Our product drawings are available in CAD format.

The architects' programme and further information on Hörmann products can be found on the Internet at www.hoermann.com.

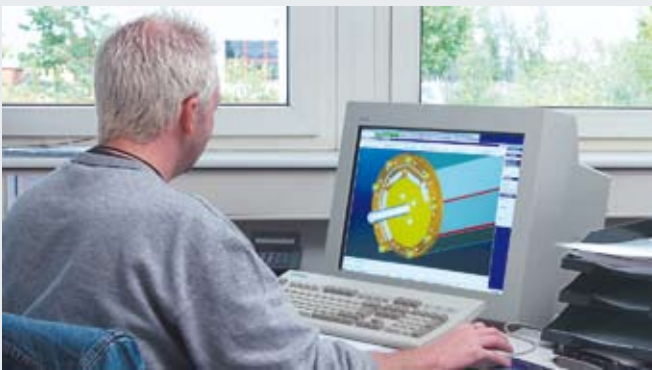

High-speed progress

Without on-going development and improvements by our highly-qualified technicians as well as comprehensive knowledge of all the market requirements, efficient high-speed door designs of a recognised high standard would not be possible.

The new spiral door HS 7030 PU is the best example of this.



Precise production

Innovative production processes that have been matched perfectly with each other are a guarantee for steadily increasing product quality. An example: The modern hot air welding system that enables a precise and automated welding of the door curtains.

Hörmann high-speed doors

Much more than simply fast



Hörmann high-speed doors are used both inside and as exterior doors to optimise the flow of traffic, improve room conditions and save energy. The Hörmann programme includes vertically and horizontally opening transparent doors with flexible curtains, as well as insulated spiral doors. Thanks to standard equipment with an FU frequency converter control and safety light grille, all Hörmann high-speed doors are exceptionally long-lasting and easy to service.

Our high standards ensure you high security from the development stage through production and quality assurance up to professional fitting.



Certified safety
Hörmann high-speed doors are manufactured in line with stringent European standards and are certified as well.



It goes without saying that spare parts for doors, operators and controls are original Hörmann parts that come with a guaranteed availability of 10 years.



Competent advice

Experienced specialists within our customer-oriented sales organisation accompany you from the planning stage, through technical clarification up to the final building inspection. Complete working documentation is not only available in printed form but is always accessible and up-to-date at www.hoermann.com.



Efficient service

Our extensive service network means that we are never far away. This is a major advantage in terms of inspections, maintenance and repairs.

The fast spiral door HS 7030 PU //NEW

External door with PU insulating panels for high thermal insulation



The spiral door HS 7030 PU is characterised by an elegant Micrograin surface finish with hot-galvanized, double-skinned steel sections providing excellent thermal insulation, fast opening speeds thanks to non-contact roll-up technology and a standard safety light grille.

Innovative technology and design in every detail



Non-contact roll-up technology

The sections are guided in a spiral bracket for especially fast opening speeds and precise door travel. Thanks to non-contact roll-up technology, there is no wear on the door sections, which helps the door to keep its exclusive appearance for a long time. In addition, the standard frequency converter control takes stress off the entire door mechanism, thus extending the service life of the door.

Uniformly foamed steel sections

Hot-galvanized, double-skinned sections with PU rigid foam infill provide for particularly high thermal insulation with a U_D value of $1.95 \text{ W}/(\text{m}^2\text{K})^*$. Doors are supplied as standard in White aluminium (RAL 9006). The exterior is characterised by the fine Micrograin lines, on the interior the sections are Stucco-textured.



External view with Micrograin surface



External view of glazing

Optional glazing

26-mm-thick DURATEC double glazing guarantees maximum scratch resistance and excellent thermal insulation values. An aluminium rail construction in natural finish E6/EV1 divides the glazing using stabilising intermediate spacers. DURATEC triple glazing is also available on request for even better thermal insulation.

Non-contact safety

The safety light grille integrated in the frame monitors the closing zone of the door up to a height of 2500 mm. This does away with the need for additional installations on the door (e.g. closing edge safety device, photocell). Profit from this high level of safety with a high-speed door that is exceptionally easy to fit and service.



* For 25 m^2 door surface

Spiral door HS 7030 PU //NEW

For inside and outside





Speed with a top design

The powerful spiral door 7030 PU with foamed sections and Micrograin surface, making it the epitome of modern industrial design. The combination with the powerful 3-phase frequency converter control (FU) enables opening speeds of up to 2.5 m/sec. The sections are securely guided in the spiral bracket without contacting each other.



** With the exception of pearl-effect, fluorescent and metallic colours. Dark colours should not be used for doors that are exposed to the sun, as possible section deflection may restrict the door's function.

External door/internal door	HS 7030 PU
Size range	
Max. width (LDB)	6500 mm
Max. height (LDH)	6000 mm
Speed	
With standard FU control AS 500 FU E	
Max. opening speed	2.5 m/sec.
Max. closing speed	0.5 m/sec.
Emergency opening/emergency closing	
Hand chain with spring compensation support	
Door leaf	
Material	Steel sandwich construction, PU-foamed Optionally with DURATEC glazing
Depth	42 mm
Section height	225 mm
Hinge connections from approx. 3500 mm door width	
Resistance to wind load (EN 12424)	
Class 4 ~ 130 km/h	
Acoustic insulation (EN 717-1)	
R = 22 dB	
Thermal insulation (EN 13241)	
For 25 m ² door size	U _D = 1.95 W/(m ² K)
Door leaf colours**	
Available in over 200 colours based on RAL.	

Flexible high-speed doors

For inside and outside



Flexible high-speed doors from Hörmann have been designed for safe, efficient and lasting operation. A standard light grille does away with the need for additional installations, such as a closing edge safety device, making the door particularly easy to fit and service.



// NEW
Non-contact safety

The standard safety light grille (IP 67) monitors the closing zone of the door up to a height of 2500 mm. A closing edge safety device is not required. Fitting in the frame also reduces the risk of collision damage. These advantages are what makes Hörmann high-speed doors especially easy to service and fit.

Impulses for a longer service life and increased efficiency

At Hörmann, you receive all high-speed doors with a frequency converter control (FU) as standard – for fast, safe and low-wear door travel. High opening and closing speeds help you to optimise your operations and reduce heat losses and draughts at the workplace. In addition, it relieves the entire door mechanism through the smooth starting and braking action which considerably extends the service life of the door.



No downtimes resulting from a crash thanks to the SoftEdge bottom profile

The innovative SoftEdge door technology prevents damages and resulting downtimes of the door system. Extensive repairs, such as those with rigid bottom profiles, do not become necessary. SoftEdge ensures trouble-free operation and production processes.



// NEW
Radio crash switch (patent pending)

The radio crash switch is concealed in the SoftEdge bottom profile. If the bottom profile is pushed out of the side guides by a crash, the radio crash switch transmits a signal to the control and **the door is stopped immediately**. Thanks to this technology, the door can be operated for up to 3 years without the need for maintenance, regardless of the number of door cycles.

SoftEdge bottom profile with integrated radio crash switch

V 2715 SEL R

Internal door with SoftEdge and tubular drive



For logistics areas and supermarkets

Storage shelves often do not permit a gearbox that protrudes on the side. Here, the high-speed door V 2715 SEL R with the tubular drive integrated in the door shaft is an optimum solution.

Fully equipped

The fast and quiet running of the door due to the standard frequency converter (FU) control, the safety light grille and the increased personal safety that results from the vertically flexible SoftEdge bottom profile with manual insertion make the door a safe internal door for areas with little space.

The shaft cover that is limited to the door width is available in a galvanized version and, on request, in a powder-coated version based on RAL.

Fitted quickly and simply

To enable a quick fitting, the door shaft is already assembled with the tubular drive at the factory.



Flush shaft cover and side guide, gearbox does not protrude on sides.

Internal door	V 2715 SEL R
Size range	
Max. width (LDB)	2750 mm
Max. height (LDH)	3000 mm
Speed	
With standard FU control BK 150 FUE H	
Max. opening speed	1.5 m/sec.
Max. closing speed	0.8 m/sec.
Emergency opening	
Optional: automatic door opening via UPS in case of power failure (BS 150 FUE H UPS, 230 V)	
Curtain	
Spring steel in curtain pockets or aluminium profile	
Fabric thickness	1.5 mm
Vision panel thickness	2.0 mm
Curtain colours	
RAL 1018 Zinc yellow	
RAL 2004 Pure orange	
RAL 3002 Carmine red	
RAL 5010 Gentian blue	
RAL 7038 Agate grey	

V 5015 SEL

Internal door with SoftEdge and anti-crash



Especially economical

The inexpensive high-speed door for inside, with SoftEdge bottom profile and standard FU control for safe and gentle continual operation.

The curtain stability of the door type V 5015 SEL is achieved through proven aluminium profiles and a horizontally stable SoftEdge bottom profile at the lower edge.

Aluminium profiles

In case of repair, the inexpensive curtain stabilization allows the curtain segments to be replaced quickly and easily.



Curtain stability with aluminium profiles

Internal door	V 5015 SEL
Size range	
Max. width (LDB)	5000 mm
Max. height (LDH)	5000 mm
Speed	
With standard FU control BK 150 FUE H	
Max. opening speed	1.5 m/sec.
Max. closing speed	0.8 m/sec.
Emergency opening	
Crank handle	
Optional: automatic door opening via UPS in case of power failure (BS 150 FUE H UPS, 230 V)	
Emergency hand chain	
Curtain	
With aluminium profile	
Fabric thickness	1.5 mm
Vision panel thickness	2.0 mm
Curtain colours	
RAL 1018 Zinc yellow	
RAL 2004 Pure orange	
RAL 3002 Carmine red	
RAL 5010 Gentian blue	
RAL 7038 Agate grey	

V 5030 SEL

Internal door with SoftEdge and anti-crash



Quiet and fast

In areas with a low noise level, a door should cause little noise, too, and work quickly and reliably even with strong draughts.

This is why the V 5030 SEL door type is equipped with spring steel wind locks that provide the necessary curtain stability.

The speed of up to 3 m/sec. is achieved through the optional Hörmann AS 500 FU E control.

Spring steel wind lock

Integrated in a curtain pocket, with lateral twin rollers, ensures quiet door travel and allows for higher wind loads.

You can also optionally obtain the V 5030 SEL with aluminium bottom profile for wind class 1 (DIN EN 12424).



Spring steel wind lock

Internal door	V 5030 SEL
Size range	
Max. width (LDB)	5000 mm
Max. height (LDH)	5000 mm
Speed	
With standard FU control BK 150 FUE H	
Max. opening speed	2.0 m/sec.
Max. closing speed	0.8 m/sec.
Optional control AS 500 FU E	
Max. opening speed	3.0 m/sec.
Max. closing speed	0.8 m/sec.
Emergency opening	
Crank handle	
Optional: automatic door opening via UPS in case of power failure (BS 150 FUE H UPS, 230 V)	
Emergency hand chain	
Curtain	
Spring steel wind lock with side rollers	
Fabric thickness	1.5 mm
Vision panel thickness	2.0 mm
Resistance to wind load (EN 12424)	
With aluminium bottom profile	Class 1 ~ 88 km/h
Curtain colours	
RAL 1018 Zinc yellow	
RAL 2004 Pure orange	
RAL 3002 Carmine red	
RAL 5010 Gentian blue	
RAL 7038 Agate grey	

V 6030 SEL

Internal and external door with SoftEdge and anti-crash



For highly-frequented transport routes, with crash-protection

External doors are driven into, e.g. by forklifts, more frequently than internal doors. This is where crash-protection pays off because it significantly reduces downtimes and repair costs.

And the high speeds at which the door opens and closes also save on energy costs.

Spring steel wind lock in curtain pocket

The lateral twin rollers ensure quiet door travel and allow reliable stops. Even wind loads of up to 80 km/h do not pose problems thanks to the spring steel wind protectors.

You can also optionally obtain the V 6030 SEL with aluminium bottom profile.



Spring steel wind lock



SoftEdge bottom profile with integrated radio crash spring switch

External door	V 6030 SEL
---------------	------------

Size range	
Max. width (LDB)	5000 mm
Max. height (LDH)	6000 mm

Speed	
With standard FU control BK 150 FUE H	
Max. opening speed	2.0 m/sec.
Max. closing speed	0.8 m/sec.
Optional control AS 500 FU E	
Max. opening speed	3.0 m/sec.
Max. closing speed	0.8 m/sec.

Emergency opening
Crank handle
Optional: automatic door opening via UPS in case of power failure (BS 150 FUE H UPS, 230 V)
Counter weights with back-up battery, Emergency hand chain

Curtain	
Spring steel wind lock with lateral twin rollers and tensioning system	
Fabric thickness	1.5 mm
Vision panel thickness	2.0 mm

Resistance to wind load (EN 12424)
Class 2 ~ 100 km/h

Curtain colours
RAL 1018 Zinc yellow, RAL 2004 Pure orange
RAL 3002 Carmine red, RAL 5010 Gentian blue
RAL 7038 Agate grey

V 6020 TRL

Internal and external door, transparent curtain



Fully transparent for more light

The fully transparent high-speed door V 6020 TRL is suitable for high ingress of light as an external door but also for an improved view in internal areas.

The 4-mm-thick transparent curtain lets light into the room resulting in a pleasantly bright workplace.

If used as an external door, we recommend the heavy, partially transparent version.

See what's coming at you

The routes of transport are made safer as a result of the free field of vision, also from far away. Fully transparent curtains are available for door sizes of up to 25 m²; from 25 m² only fabric curtains, with or without a vision field.

Wind lock

In addition to the tensioning system fitted as standard, spring steel wind locks ensure the necessary curtain stability.



Transparent for more incidence of light and a free field of vision



Aluminium bottom profile for outside use

External door	V 6020 TRL
Size range	
Max. width (LDB)	6000 mm
Max. height (LDH)	7000 mm
Speed	
With standard FU control BK 150 FUE H (door size up to max. 3500 x 3500 mm)	
Max. opening speed	1.5 m/sec.
Max. closing speed	0.5 m/sec.
Optional control AS 500 FU E	
Max. opening speed	2.0 m/sec.
Max. closing speed	0.5 m/sec.
Emergency opening	
Crank handle	
Optional: automatic door opening via UPS in case of power failure (BS 150 FUE H UPS, 230 V) (door size up to max. 3500 x 3500 mm)	
Emergency hand chain	
Curtain	
Fully transparent curtain thickness	4.0 mm
Fabric thickness	2.4 mm (from 25 m ² door size)
Resistance to wind load (EN 12424)	
Class 2 ~ 100 km/h	
Wind lock strip colours	
RAL 1018 Zinc yellow	
RAL 2004 Pure orange (optional curtain colour)	
RAL 3002 Carmine red	
RAL 5010 Gentian blue (optional curtain colour)	
RAL 7038 Agate grey (optional curtain colour)	

V 10008

Large door for outside use



For oversized openings

Double lashing straps and especially wide side guides ensure safe door travel even with a high door curtain weight. The standard FU control and double closing edges on the bottom profile ensure that the closing force is maintained and provide the door with its required safety.

Spring steel wind lock in curtain pocket

The lateral twin rollers ensure quiet door travel and allow higher wind loads. The number of wind protectors is determined by the door size, load requirements and the installation situation.



Spring steel wind lock



Especially wide side guide

External door	V 10008
Size range	
Max. width (LDB)	10000 mm
Max. height (LDH)	6250 mm
Speed	
With standard FU control AS 500 FU E (door width up to 6000 mm)	
Max. opening speed	1.5 m/sec.
Max. closing speed	0.5 m/sec.
(door width from 6000 mm)	
Max. opening speed	0.8 m/sec.
Max. closing speed	0.4 m/sec.
Emergency opening	
Emergency hand chain	
Curtain	
Fabric thickness	1.5 mm
Vision panel thickness	2.0 mm
Resistance to wind load (EN 12424)	
(door width up to 6000 mm)	Class 3 ~ 115 km/h
Wind lock	
Spring steel with lateral twin rollers	
Curtain colours	
RAL 1018 Zinc yellow	
RAL 2004 Pure orange	
RAL 3002 Carmine red	
RAL 5010 Gentian blue	
RAL 7038 Agate grey	

High-speed doors for special applications



V 3015 RW

Internal door with SoftEdge for rescue routes



The internal door for rescue routes with decisive advantages

Thanks to a SoftEdge profile with anti-crash system, these high-speed doors are especially safe and economical. People are better protected and damage and downtimes are avoided.

Approved for use in rescue routes

With certified qualification, these high-speed doors can be integrated into rescue route planning.

A type-tested door must undergo an initial inspection by a specialist.

Standard equipment

Radars detector for advanced protection in the escape direction, emergency open button.



Radars detector in escape direction as standard



Internal door	V 3015 RW
Size range	
Max. width (LDB)	3000 mm
Max. height (LDH)	3000 mm
Speed	
With standard FU control BK 150 FUE H	
Max. opening speed	1.5 m/sec.
Max. closing speed	0.8 m/sec.
Anti-crash system	
With re-feed on both sides	
Emergency opening	
Counter weight with operating current brake	
Curtain	
Aluminium profile	
Fabric thickness	1.5 mm
Vision panel thickness	2.0 mm
Curtain colours	
RAL 1018 Zinc yellow	
RAL 2004 Pure orange	
RAL 3002 Carmine red	
RAL 5010 Gentian blue	
RAL 7038 Agate grey	

Iso Speed Cold

Fast, energy-saving door as a cold store and deep freeze door



Fast, airtight and extremely efficient

Thanks to its heated panels and special seals for the building structure and floor, the Iso Speed Cold is the optimum solution for all areas with high temperature differences. Used as a high-speed door in cold-storage areas or to save energy in production and distribution areas, the Iso Speed Cold remains impervious.

With thermal breaks

The steel sections in the Iso Speed Cold have thermal breaks separating the interior from the exterior. An excellent thermal insulation value of $U_T = 0.3 \text{ W}/(\text{m}^2\text{K})$ is attained with additional lintel and bottom seals.

Exceptionally airtight

The double-skinned door leaf is foam-filled with CFC-free polyurethane (PU) rigid foam. Thus it is especially stable and attains exceptional insulation values in conjunction with the all-round sealing frame.

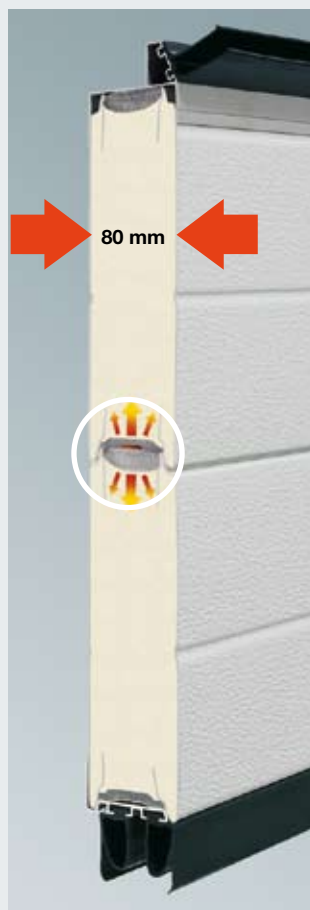

Heated panels

Internal door	Iso Speed Cold	
Size range		
	Outside (cold store)	Inside (freezer)
Max. width (LDB)	5000 mm	4000 mm
Max. height (LDH)	5000 mm	4000 mm
Speed		
With standard FU control AS 500 FU E		
Max. opening speed	2.0 m/sec.	
Max. closing speed	0.5 m/sec.	
Panel		
PU foam filling		
Thickness	80 mm	
Emergency opening		
Counter weight with pull cord		

Panel heating in diverted doors

Thermal breaks at the section transitions

V 4015 Iso L

Internal door for fresh and cold logistics



For cold and fresh foods with insulated curtain for good thermal values

The energy-saving door in internal areas for cold and fresh logistics.

A thermal insulation value of $U_T = 1.2 \text{ W}/(\text{m}^2\text{K})$ is achieved.



Wind lock



20 mm thick insulated curtain

Internal door	V 4015 Iso L
Size range	
Max. width (LDB)	4000 mm
Max. height (LDH)	4500 mm
Speed	
With standard FU control BK 150 FUE H	
Max. opening speed	1.5 m/sec.
Max. closing speed	0.5 m/sec.
Emergency opening	
Crank handle	
Optional:	
Automatic door opening via UPS in case of power failure (BS 150 FUE H UPS, 230 V)	
Curtain	
PO foam Thickness	20 mm

V 2515 Food L

Internal door for wet areas in the food industry



Easy to clean

The side guides in this special version are easy to clean. High-pressure cleaning systems and water are not a problem for the door construction, which is made entirely of stainless steel. No counter weights or springs prevent the frame from being cleaned.

Spray-water protected

The operator is completely enclosed in a splash-water protected operator cover made of V2A stainless steel (protection category IP 65).

The safety light grille complies with protection category IP 67.



The door is supplied with a UPVC seal and safety light grille in the frame as standard.



Easy to clean

Internal door	2515 Food L
Size range	
Max. width (LDB)	2500 mm
Max. height (LDH)	3000 mm
Speed	
With standard FU control BS 150 FUE H V2A	
Max. opening speed	2.0 m/sec.
Max. closing speed	0.8 m/sec.
Emergency opening	
Optional: Automatic door opening via a UPS in case of power failure (BS 150 FUE H V2A UPS, 230 V)	
Curtain	
Spring steel in curtain pockets	
Fabric thickness	1.5 mm
Vision panel thickness	2.0 mm
Curtain colours	
RAL 1018 Zinc yellow	
RAL 2004 Pure orange	
RAL 3002 Carmine red	
RAL 5010 Gentian blue	
RAL 7038 Agate grey	

V 2012

Internal door for use in supermarket



The completely equipped door

Full equipment with operator and shaft cover, a standard light grille and automatic emergency opening via a counter weight (in case of power failure) all make this flexible plastic curtain door a reliable internal door for areas with high customer frequency.

Anti-crash system with automatic start-up

With a durable, light curtain and an extremely flexible bottom part, the door is back in operation within seconds of a crash. This high level of flexibility does away with the need for a closing edge safety device.

FU control

With the standard FU control BK 150 FU, the door achieves opening speeds of up to 1.2 m/sec.

Curtain variants

Anti-static fabric curtain, as standard without vision field. On request with an approx. 750 mm high vision panel from 1300 mm above FFL at no surcharge.



350-mm-high light grille concealed in the door guide

Internal door	V 2012
Size range	
Max. width (LDB)	2500 mm
Max. height (LDH)	2500 mm
Speed	
With standard FU control BK 150 FU	
Max. opening speed	1.2 m/sec.
Max. closing speed	0.5 m/sec.
Emergency opening	
Counter weight with operating current brake	
Curtain	
Spring steel in curtain pockets	
Fabric thickness	1.5 mm
Vision panel thickness	2.0 mm
Curtain colours	
RAL 1018 Zinc yellow	
RAL 2004 Pure orange	
RAL 3002 Carmine red	
RAL 5010 Gentian blue	
RAL 7038 Agate grey	

V 1401 ATEX

Internal door for explosive areas



V 1401 ATEX

The high-speed door for explosive areas. Developed, designed and certified in line with the directives: EC Explosion Protection 94/9EC and DIN EN 13453-1.

The control cabinet must always be fitted outside the Ex area.

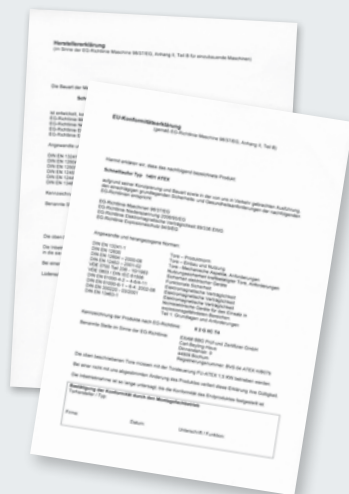

Internal door	V 1401 ATEX
Size range	
Max. width (LDB)	4000 mm
Max. height (LDH)	4000 mm
Speed	
With standard FU control BS 150 FU E	
Max. opening speed	1.4 m/sec.
Max. closing speed	0.5 m/sec.
Emergency opening	
Crank handle	
Curtain	
Aluminium profile	
Fabric thickness	1.5 mm
Vision panel thickness	2.0 mm
Curtain colours	
RAL 1018 Zinc yellow	
RAL 2004 Pure orange	
RAL 3002 Carmine red	
RAL 5010 Gentian blue	
RAL 7038 Agate grey	

V 3015 Clean

Internal door for clean rooms, transparent curtain



Special curtain for pressure differences

Air purification in clean rooms can result in a pressure difference of up to 50 Pa. The fully-transparent curtain of this clean-room door is tightly integrated in the special side guides. This minimizes air loss (leakage). This enables an optimum design for ventilation systems. A stainless steel cover on the shaft and operator, and welded-on spring steel stabilisation are further characteristics of this door.



Extremely leaktight and fully transparent



Curtain tightly integrated in the side guides

Internal door	V 3015 Clean
Size range	
Max. width (LDB)	2500 mm
Max. height (LDH)	3000 mm
Speed	
With standard FU control BS 150 FU E	
Max. opening speed	1.5 m/sec.
Max. closing speed	0.5 m/sec.
Emergency opening	
Crank handle	
Optional: automatic door opening via UPS in case of power failure (BS 150 FUE H V2A UPS, 230 V)	
Curtain	
Spring steel stabilisation welded into pockets	
Fully transparent curtain thickness	4.0 mm
Wind lock strip colours	
RAL 1018 Zinc yellow	
RAL 2004 Pure orange	
RAL 3002 Carmine red	
RAL 5010 Gentian blue	
RAL 7038 Agate grey	

V 3009

Internal door for conveyor systems



Designed for continual operation

The V 3009 is fitted between the operating sections and the storage areas within the conveyor system and is used to save energy and reduce draughts and noise. The door is designed for a high number of automated opening and closing cycles.

The door control can be integrated in existing PLC systems. A volt-free contact reports the door position (open/closed) to the control.



The door is also available with a vision panel.

Internal door	V 3009 Conveyor
Size range	
Max. width (LDB)	3000 mm
Max. height (LDH)	3000 mm
Speed	
With standard control AK E (contactor)	
Max. opening speed	0.8 m/sec.
Max. closing speed	0.8 m/sec.
With optional FU control BK 150 FUE H	
Max. opening speed	1.2 m/sec.
Max. closing speed	0.5 m/sec.
Emergency opening	
Crank handle	
Curtain	
Aluminium profile	
Fabric thickness	1.5 mm
Vision panel thickness	2.0 mm
Curtain colours	
RAL 1018 Zinc yellow	
RAL 2004 Pure orange	
RAL 3002 Carmine red	
RAL 5010 Gentian blue	
RAL 7038 Agate grey	

H 3530

Fast horizontal door



Opens quickly, crashes virtually excluded

Our quickest door for internal applications. The door leaves quickly open to the sides and immediately make the full passage height available. This guarantees fast flow of traffic and increases safety, above all for personnel traffic. Even with the high opening speed of 3 m/sec., the door is subject to minimum wear thanks to the frequency converter control which provides the door with a soft start and stop.

Further benefits: Two opening widths can be programmed for personnel and vehicles. Closing edge safety devices and photocells provide additional safety. In the event of a malfunction, the door can quickly be opened with a hand pulley or automatically during a power failure by using an operating current brake (special equipment).

The complete operator technology is always located on the right

in a space-saving manner in 3-sided cladding and only requires minimum headroom.



The stainless-steel version fulfils the hygienic requirements of the food, chemical and pharmaceutical industries.

Internal door	H 3530
Size range	
Max. width (LDB)	3500 mm
Max. height (LDH)	3500 mm
Speed	
With standard FU control BK 150 FUE H	
Max. opening speed	3.0 m/sec.
Max. closing speed	1.0 m/sec.
Emergency opening	
Springs with pull cord	
Optional:	
Springs with operating current brake	
Curtain	
Fabric thickness	1.5 mm
Vision panel thickness	2.0 mm
Wind lock strip colours	
RAL 1018 Zinc yellow	
RAL 2004 Pure orange	
RAL 3002 Carmine red	
RAL 5010 Gentian blue	
RAL 7038 Agate grey	

Intelligent operator and control technology Standard at Hörmann



Reliable thanks to innovative equipment

Hörmann high-speed doors are up to 20 times faster than conventional industrial doors. Which is why the intelligent operator and control technology is designed for reliable continuous operation. All operators and controls are equipped with plug-in terminals to allow the control circuit boards to be easily changed (control voltage 24 V DC).

Standard at Hörmann:

Frequency converter control

High performance frequency converter controls (FU). FU controls feature higher speeds and relieve the complete door mechanism which, in turn, extends the service life of the door considerably.

Door cycle counter

Operation time monitoring

Automatic timer (hold-open phase adjustable)

Error display/diagnosis via a fourfold 7-segment display

Service operation setting



FU controls



BK 150 FUE H
FU control in plastic housing IP 54,
one-phase, 230 V

Operation

Open-Stop-Close membrane push button, fourfold 7-segment display for information on door functions

Function

Automatic timer, hold-open phase adjustable up to 200 sec., safety light grille, closing edge safety device, stop reopen

Impulse generator

Push button, pull switch, mushroom button, radar presence detector, slots for induction loop detector and Radio remote control

Extension options

Main switch, traffic lights, flashing warning light, locking, intermediate stop, extension PCB E FU H, stainless steel cabinet IP 65

Wiring

Connecting lead 1~230 V, N, PE, fuse 16 A, slow-acting, Plug-in connection between door operator and control cabinet CEE plug, 3-pin with 1 m cable for on-site CEE socket, 16 A

Housing dimensions

200 × 400 × 200

Compatible door types

V 5015 SEL
V 5030 SEL (up to 2 m/s)
V 6030 SEL (up to 2 m/s)
V 6020 TRL (up to 12.25 m²)
V 2715 SEL R
V 2012
V 4015 Iso L
H 3530



AS 500 FU E
FU control in steel cabinet IP 54
3-phase, 400 V

Operation

Open-Stop-Close membrane push button, emergency-Off button, fourfold 7-segment display for information on door functions, lockable main switch

Function

Automatic timer, hold-open phase adjustable up to 200 sec., safety light grille, closing edge safety device, stop reopen

Impulse generator

Push button, pull switch, mushroom button, radar presence detector, slots for induction loop detector and Radio remote control

Extension options

traffic lights, flashing warning light, locking, intermediate stop, extension PCB R FU X, stainless steel cabinet IP 65

Wiring

Connecting lead 3~400 V, N, PE, fuse 16 A, slow-acting, Plug-in connection between door operator and control cabinet

Housing dimensions

400 × 600 × 200

Compatible door types

V 10008
V 5030 SEL (up to 3 m/s)
V 6030 SEL (up to 3 m/s)
V 6020 TRL
HS 7030 PU
Iso Speed Cold

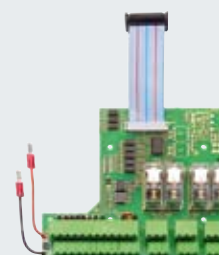

E FU H / R FU X
Extension PCB for controls:
BK 150 FUE H (E FU H)
AS 500 FU E (R FU X)

Lock controller
4 additional switch outputs
(2 × 2 volt-free)
8 additional digital inputs

Accessories

Operating and controlling options

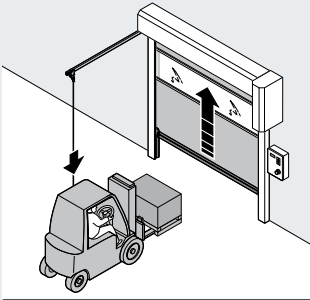

Manually operated impulse generators



Pull switch with plastic pull cord
Horizontal or vertical fitting possible,
die-cast aluminium housing IP 65,
cord length 4 m.

**To operate an efficient door system,
it is important to choose the right impulse
generator. You should therefore consult
your Hörmann specialist adviser.**

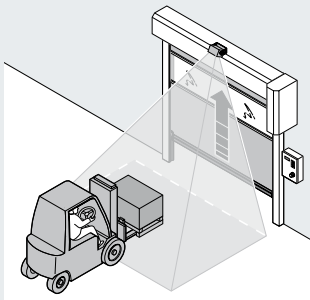

Remote controls



Comfort radar/presence detector
Radar movement and presence detection
with infrared detection.
Quick and targeted automatic door opening.
Reliable protection of the area in front of the door.
Up to max. 6 m height.
In areas with high levels of humidity and in
outside areas, only the radar function is available.
Housing: protection category IP 65

Accessories

Operating and controlling options

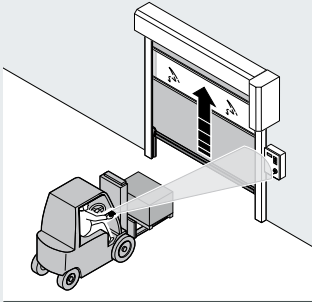

Radio remote controls



4-button hand transmitter HS 4



1-button hand transmitter HS 1



Hand transmitter HSI
For up to 999 doors, with user-friendly operation via a large display



Receiver HER 1 (1-channel)
With volt-free relay output in a separate housing without a connecting lead or as a plug-in circuit board in the control cabinet.

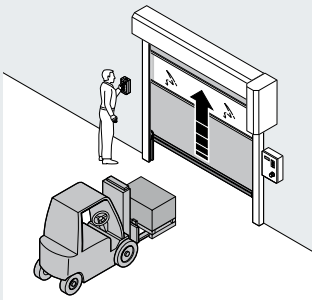

Manually operated impulse generators



Push button
2 x "Open/Close"
Plastic housing IP 65



Push button
3 x "Open/
Emergency-off/Close"
Plastic housing IP 65



Mushroom button
With large operating surface
Plastic housing IP 65



Finger-scan FL 12, FL 100
Your fingerprint is enough.
The finger-scan is available in two versions, as an FL 12 or FL 100 to store 12 or 100 fingerprints, respectively.



Radio code switch FCT 10b
Using a radio code switch FCT 10b, you are able to transmit up to 10 radio codes (868.3 MHz). No laying of cables required.
The keypad illuminates when initially pressed.

Accessories

Operating and controlling options

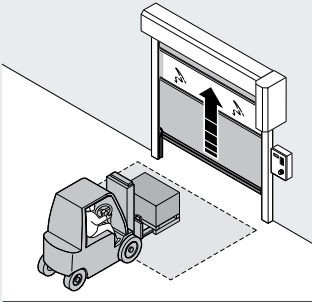

Induction loops

Induction loop detector

1 or 2-channel plug-in print.
Suitable for two separate induction loops.
Supplied without loop cable.

To operate an efficient door system, it is important to choose the right impulse generator. You should therefore consult your Hörmann specialist adviser.

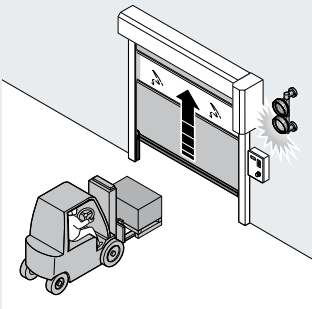

Safety equipment

Warning light Ø 150 mm

Red,
in a plastic housing,
with mounting strap,
IP 65

Warning light Ø 150 mm

Red, green,
in a plastic housing,
with fitting support,
IP 65

Rotating warning light

Red or yellow,
in a plastic housing,
IP 54

Flashing warning light

Orange,
in a plastic housing,
IP 65



Light grille

Safety equipment 1590 mm high,
beam distance 60 mm,
transmitter and receiver, IP 65
crossed with cable box M 12,
plug-in.

Spiral door

Technical Data

		HS 7030 PU	
Use	Internal door	●	
	External door	●	
Speed	Opening speed approx. m/sec.	1.5 - 2.5	
	Closing speed approx. m/sec.	0.5 - 0.8	
Safety equipment	DIN EN 13241.1	●	
Resistance to wind load	DIN EN 12424	Class 4	
Resistance to water penetration	DIN EN 12425	Class 3	
Air permeability	DIN EN 12426	-	
Transmission of heat	DIN EN 12428	1.0	
Acoustic insulation	DIN EN 52210 dB	22	
Shutter sizes	Max. width LDB	6500	
	Max. height LDH	6000	
Fitting dimensions (space requirement) (See also the Technical Manual)	Operator side (with cladding)	510 (610)	
	Bearing side (with cladding)	365 (415)	
	Lintel (with cladding)	-	
	Lintel LDH up to 5000 mm (with cladding)	885 (970)	
	Lintel LDH from 5001 to 6000 mm (with cladding)	920 (1005)	
	Control in steel cabinet (W × H × D)	400x600x200	
Door construction	Self-supporting	-	
Door leaf counterbalance		●	
Door leaf	Double-skinned section thickness	42	
	Foamed door leaf	●	
Material/surface of door leaf	Steel, RAL 9006	●	
	Wet coating in RAL to choose	○	
	Aluminium rail window, anodised aluminium E6/EV1	●	
Glazing	Double synthetic panes	●	
	Triple synthetic panes	○	
Ventilation grille	Ventilation cross section depending on size/version (min. 30%)	○	
Operator and control	Frequency converter	●	
	Connecting voltage	3-400 V, N, PE	
	Open-Stop-Close button	●	
	Main switch all-pole switch off	●	
	Fuse protection	16 A, slow-acting	
	Protection category for operator and control	IP 54	
	Emergency-Off button	○	
	Route monitoring	Safety light grille IP 67	●
		Photocell	-
		Light grille 500 mm high	-
	Door area monitoring	Radar presence detector	○
		Induction loop	○
	Hold-open phase in sec.	1-200	
	Closing edge safety device	-	
	Electronic limit switch DES	●	
Emergency opening	Emergency crank handle	-	
	Emergency hand chain	●	
	Counter weight/spring	-/●	
	FU control with UPS 230 V	-	
Volt-free contacts		○	
Impulse generator		○	
Safety devices		○	

- Standard
- Optional

Flexible high-speed doors

Technical Data

		V 2715 SEL R	V 5015 SEL	V 5030 SEL	
Use	Internal door	●	●	●	
	External door			Wind protected, optionally with aluminium bottom profile	
Speed	FU control	Opening speed approx. m/sec.	1.5	1.5	2.0 - 3.0
		Closing speed approx. m/sec.	0.8	0.8	0.8
Safety equipment	DIN EN 13241	●	●	●	
Wind load	DIN EN 12424	Class 0	Class 0	Class 0/1 with aluminium bottom profile	
Wind lock		●	●	●	
Shutter sizes	Max. width LDB	2750	5000	5000	
	Max. height LDH	3000	5000	5000	
Fitting dimensions (space requirement) (See also the Technical Manual)	Operator side	LDB + mm (with cladding)	- (205)	345 (375)	385 (425)
	Bearing side	LDB + mm (with cladding)	- (205)	175 (175)	255 (290)
	Lintel	LDH + mm	-	440	440/520 ¹⁾
		LDH + mm, straight cladding	460	490	490/570 ¹⁾
		LDH + mm cladding 30° (5°)	-	630	630/710 ¹⁾
	FU control in plastic cabinet (W × H × D)	200 × 400 × 200	200 × 400 × 200	200 × 400 × 200	
FU control in steel cabinet (W × H × D) (stainless steel 1.4301) UPS	400 × 600 × 200	400 × 600 × 200	400 × 600 × 200		
Anti-crash/crash-protection	With automatic/manual start-up	Crash-protection	Anti-crash	Anti-crash	
Door construction	Self-supporting	●	●	●	
	Fabric/transparent	1.5/2.0 mm	●	●	
	Transparent	4.0 mm	-	-	
Curtain/door leaf tension		-	-	-	
Material/surface guide	Galvanized steel	●	●	●	
	Galvanized steel, coated, in colours based on RAL	○	○	○	
	Polished stainless steel V2A	○	○	○	
Shaft/operator cover	Straight	●	○	○	
	30° chamfered (5°)	-	○	○	
Operator and control	FU control	●	●	●	
	Connecting voltage (1-phase)	1-230 V, N, PE	1-230 V, N, PE	1-230 V, N, PE	
	Connecting voltage (3-phase)	-	-	3-400 V, N, PE	
	Open-Stop-Close button	●	●	●	
	FU control, main switch all-pole switch off, 1-phase/3-phase	○/–	○/–	○/●	
	Fuse protection	16 A, slow-acting	16 A, slow-acting	16 A, slow-acting	
	Protection category	Operator, control	IP 54	IP 54	IP 54
	Emergency-Off button		○	○	○
	Route monitoring	Safety light grille IP 67	●	●	●
		Photocell	-	-	-
		Light grille 500 mm high	-	○	○
	Door area monitoring	Radar presence detector	○	○	○
		Induction loop	○	○	○
	Hold-open phase in sec.		1-200	1-200	1-200
	Closing edge safety device	With energy chain	-	-	-
Electronic limit switch DES		●	●	●	
Emergency opening	Crank handle	-	●	●	
	Emergency hand chain	-	○	○	
	Counter weight/springs	-/-	-/-	-/-	
	FU control with UPS 230 V	○	○	○	
Volt-free contacts		○	○	○	
Impulse generator		○	○	○	
Safety devices		○	○	○	

● Standard

○ Optional

1) With aluminium bottom part

Flexible high-speed doors

Technical Data

		V 6030 SEL	V 6020 TRL	V 10008	
Use	Internal door	●	●	●	
	External door	●	●	●	
Speed	FU control	Opening speed approx. m/sec.	2.0 - 3.0	1.5 - 2.0	0.8 - 1.5
		Closing speed approx. m/sec.	0.8	0.5	0.4
Safety equipment	DIN EN 13241	●	●	●	
Wind load	DIN EN 12424	Class 2	Class 2	Class 3	
Wind lock		●	●	●	
Shutter sizes	Max. width LDB	5000	6000	10000	
	Max. height LDH	6000	7000	6500	
Fitting dimensions (space requirement) (See also the Technical Manual)	Operator side	LDB + mm (with cladding)	460 (505)	420 (470)	545 (580)
	Bearing side	LDB + mm (with cladding)	335 (355)	300 (300)	390 (390)
	Lintel	LDH + mm (with curtain fixing)	540 (615)	680 (760)	- (745)
		LDH + mm, straight cladding	590	720	-
		LDH + mm cladding 30° (5°)	730	870	(840)
	FU control in plastic cabinet (W × H × D)	200 × 400 × 200	200 × 400 × 200	-	
FU control in steel cabinet (W × H × D) (Stainless steel 1.4301)	400 × 600 × 200	400 × 600 × 200	400 × 600 × 200		
Anti-crash/crash-protection	With automatic/manual start-up	Crash-protection	-	-	
Door construction	Self-supporting	●	●	-	
	Fabric/transparent	1.5/2.0 mm	-	●	
	Transparent	4.0 mm	-	-	
Curtain/door leaf tension		●	●	●	
Material/surface guide	Galvanized steel	●	●	●	
	Galvanized steel, coated, in colours based on RAL	○	○	○	
	Polished stainless steel V2A	○	○	-	
Shaft/operator cover	Straight	○	○	-	
	30° chamfered (5°)	○	○	(○)	
Operator and control	FU control	●	●	●	
	Connecting voltage (1-phase)	1-230 V, N, PE	1-230 V, N, PE	-	
	Connecting voltage (3-phase)	3-400 V, N, PE	3-400 V, N, PE	3-400 V, N, PE	
	Open-Stop-Close button	●	●	●	
	FU control, main switch all-pole switch off, 1-phase/3-phase	○/●	○/●	-/●	
	Fuse protection	16 A, slow-acting	16 A, slow-acting	16 A, slow-acting	
	Protection category	Operator, control	IP 54	IP 54	IP 54
	Emergency-Off button		○	○	○
	Route monitoring	Safety light grille IP 67	●	●	-
		Photocell	-	-	●
		Light grille	○	○	○
	Door area monitoring	Radar presence detector	○	○	○
		Induction loop	○	○	○
	Hold-open phase in sec.		1-200	1-200	1-200
	Closing edge safety device	With energy chain	-	-	●
Electronic limit switch DES		●	●	●	
Emergency opening	Crank handle	●	●	-	
	Emergency hand chain	○	○	●	
	Counter weight/springs	○/-	-/-	-/-	
	FU control with UPS 230 V	○	○	-	
Volt-free contacts		○	○	○	
Impulse generator		○	○	○	
Safety devices		○	○	○	

● Standard
○ Optional

Special doors

Technical Data

			V 3015 RW	
Use	Internal door		●	
	External door		-	
Speed	FU control	Opening speed approx. m/sec.	1.5	
		Opening speed approx. m/sec.	0.8	
Safety equipment	DIN EN 13241		●	
Wind load	DIN EN 12424		Class 0	
Wind lock			-	
Shutter sizes	Max. width LDB		3000	
	Max. height LDH		3000	
Fitting dimensions (space requirement) (See also the Technical Manual)	Operator side	LDB + mm (with cladding)	325 (355)	
	Bearing side	LDB + mm (with cladding)	300 (300)	
	Lintel	LDH + mm	440	
		LDH + mm, straight cladding	490	
		LDH + mm cladding 30° (5°)	670	
	FU control in plastic cabinet	(W × H × D)	-	
FU control in steel cabinet	(W × H × D) (Stainless steel 1.4301)	300 × 400 × 150		
Anti-crash/crash-protection	With automatic/manual start-up		Anti-crash	
Door construction	Self-supporting		●	
Curtain/door leaf	Fabric/transparent	1.5/2.0 mm	●	
	Transparent	4.0 mm	-	
Curtain/door leaf tension			-	
Material/surface guide	Galvanized steel		●	
	Galvanized steel, coated, in colours based on RAL		○	
	Polished stainless steel V2A		○	
Shaft/operator cover	Straight		○	
	30° chamfered (5°)		○	
Operator and control	WU control		-	
	FU control		●	
	Connecting voltage (1-phase)		1-230 V, N, PE	
	Connecting voltage (3-phase)		-	
	Open-Stop-Close button		●	
	FU control, main switch all-pole switch off, 1-phase/3-phase		●/-	
	Fuse protection		16 A, slow-acting	
	Protection category	Operator, control		IP 54
	Emergency-Off button			●
	Route monitoring	Safety light grille IP 67		-
		Photocell		●
		Light grille 350 mm high		-
	Door area monitoring	Radar presence detector		○
Induction loop			○	
Hold-open phase in sec.			1-200	
Closing edge safety device	With energy chain		With spiral cable	
Electronic limit switch DES			-	
Emergency opening	Crank handle		-	
	Emergency hand chain		-	
	Counter weight/springs		●/-	
FU control with UPS 230 V			-	
Volt-free contacts			-	
Impulse generator			○	
Safety devices			○	

V 2515 FOOD L	V 2012	V 1401 ATEX	V 3015 CLEAN	V 3009	H 3530
●	●	●	●	●	●
-	-	-	-	-	-
1.2	1.2	1.4	1.5	(AKE 0.8)	3.0
0.8	0.5	0.5	0.5	(AKE 0.8)	1.0
●	●	●	●	●	●
Class 0	Class 0	Class 0	Class 0	Class 0	Class 0
-	-	●	-	-	-
2500	2500	4000	2500	3000	3500
3000	2500	4000	3000	3000	3500
-(355)	-(345)	435 (475)	-(380)	310 (310)	-(355)
-(200)	-(180)	150 (150/-)	-(225)	150 (180)	-(355)
-	-	660	-	300	-
-	400	700	-	335	370
(440)	-	850	(550)	480	520
-	200 × 400 × 200	-	-	200 × 400 × 200	200 × 400 × 200
300 × 400 × 150 V2A	-	600 × 600 × 200	300 × 400 × 150	-	-
Anti-crash	●	-	-	-	-
●	●	●	●	●	-
●	●	●	-	●	●
-	-	-	●	-	-
-	-	-	-	-	●
-	●	●	●	●	●
-	○	○	○	○	○
●	-	○	○	○	○
-	●	○	-	○	●
(●)	-	○	(●)	○	○
-	-	-	-	●	-
●	●	●	●	○	●
1-230 V, N, PE	1-230 V, N, PE	1-230 V, N, PE	1-230 V, N, PE	1-230 V, N, PE	1-230 V, N, PE
-	-	-	-	-	-
●	●	●	●	●	●
●/-	-	●/-	○/-	○/-	○/-
16 A, slow-acting	16 A, slow-acting	16 A, slow-acting	16 A, slow-acting	10 A (16 A, slow-acting/FU)	16 A, slow-acting
IP 65	IP 54	IP 54	IP 54	IP 54	IP 54
○	○	○	○	○	○
●	-	-	-	-	-
-	-	●	●	●	●
-	●	-	-	-	-
○	○	○	○	○	○
○	○	○	○	○	○
1-200	1-200	1-200	1-200	1-200	1-200
-	-	●	●	●	●
●	●	-	●	●	●
-	-	-	●	●	-
-	-	-	-	-	-
-	●/-	-	-	-	-
○	-	-	○	○	○
○	-	-	○	○	-
○	-	○	○	○	○
○	-	○	○	○	○

● Standard
○ Optional

Cold store and deep freeze doors

Technical Data

			Iso Speed Cold	V 4015 ISO L	
Use	Internal door		●	●	
	External door		●	-	
Speed	FU control	Opening speed approx. m/sec.	2.0	1.5	
		Opening speed approx. m/sec.	0.5	0.5	
Safety equipment	DIN EN 13241		●	●	
Wind load	DIN EN 12424		Class 3	Class 0	
Wind lock			-	●	
Shutter sizes	Max. width LB		5000	4000	
	Max. height LDH		5000	4500	
Fitting dimensions (space requirement) (See also the Technical Manual)	Operator side	LDB + mm (with cladding)	510 (-)	325 (360)	
	Bearing side	LDB + mm (with cladding/counter weight)	375 (-/375)	295 (325/-)	
	Lintel	LDH + mm	1)	630	
		LDH + mm, straight cladding	-	-	
		LDH + mm cladding 30° (5°)	- (-)	- (720)	
	FU control in plastic cabinet	(W x H x D)	-	200 x 400 x 200	
	FU control in steel cabinet	(W x H x D) (Stainless steel 1.4301)	400 x 600 x 200	400 x 600 x 200	
Anti-crash/crash-protection	With automatic/manual start-up		-	-	
Door construction	Self-supporting		●	-	
Curtain/door leaf	Door leaf	80 mm, PU-foamed	●	-	
	Curtain	20 mm, PO foam	-	●	
Curtain/door leaf tension			-	-	
Material/surface guide	Galvanized steel		●	●	
	Galvanized steel, coated, in colours based on RAL		○	○	
	Polished stainless steel V2A		○	○	
Shaft/operator cover	Straight		-	-	
	30° chamfered (5°)		-	(○)	
Operator and control	FU control		●	●	
	Connecting voltage (1-phase)		-	1-230 V, N, PE	
	Connecting voltage (3-phase)		3-400 V, N, PE	-	
	Open-Stop-Close button		●	●	
	FU control, main switch all-pole switch off, 1-phase/3-phase		-/●	○/-	
	Fuse protection		20 A, slow-acting	16 A, slow-acting	
	Protection category	Operator, control	IP 54	IP 54	
	Emergency-Off button		○	○	
	Route monitoring	Safety light grille IP 67		-	●
		Photocell		●	-
		Light grille		○	○
	Door area monitoring	Radar presence detector		○	○
		Induction loop		○	○
	Hold-open phase in sec.		1-200	1-200	
	Closing edge safety device	With energy chain		●	-
Electronic limit switch DES			●	●	
Emergency opening	Crank handle		-	●	
	Emergency hand chain		●	-	
	Counter weight/springs		●/-	-/-	
	FU control with UPS 230 V		-	○	
Volt-free contacts			○	○	
Impulse generator			○	○	
Safety devices			○	○	

● Standard

○ Optional

1) Track application N: LDH + 950 mm, track application V: LDH x 2 + 800 mm

Everything from a single source: for your building projects.

As a construction component specialist, Hörmann gives you the power to plan perfectly whatever your needs. Carefully-matched construction project solutions offer you the very best highly-functional products for every area.



1 Sectional doors



2 Rolling shutters and rolling grilles



3 Steel and aluminium folding doors



4 High-speed doors

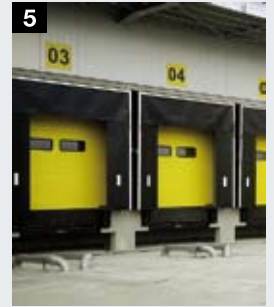

5 Loading technology



6 Fire sliding doors



7 Multi-function doors and reinforced internal doors



8 Fire and smoke-protection box frame parts



9 Visibility window



10 Service

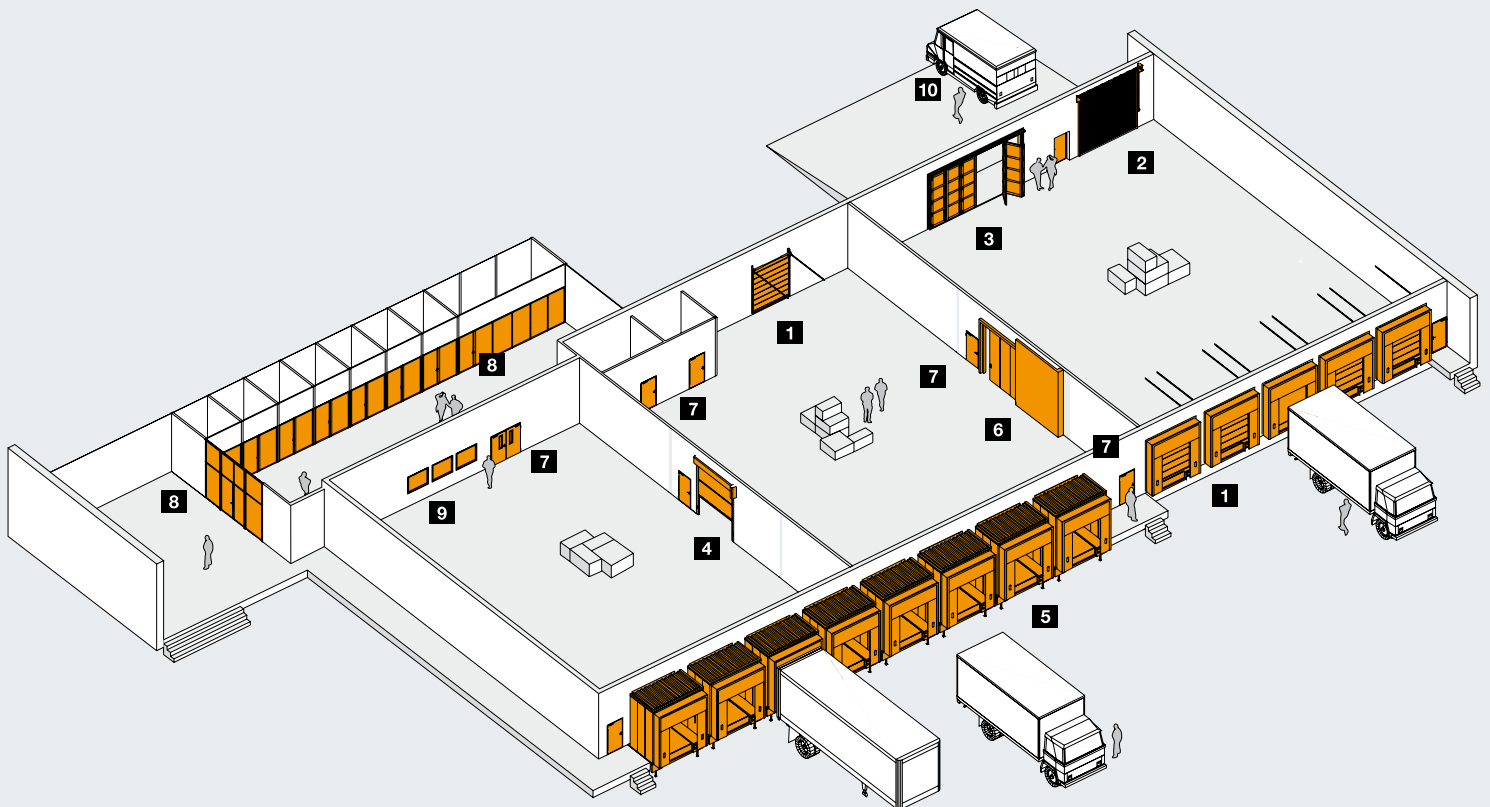

Hörmann: Quality without Compromise



Hörmann KG Amshausen



Hörmann KG Antriebstechnik



Hörmann KG Brandis



Hörmann KG Brockhagen



Hörmann KG Dissen



Hörmann KG Eckelhausen



Hörmann KG Freisen



Hörmann KG Ichtershhausen



Hörmann KG Werne



Hörmann Genk NV, Belgium



Hörmann Alkmaar B.V., Netherlands



Hörmann Legnica Sp. z o.o., Poland



Hörmann Beijing, China



Hörmann Tianjin, China



Hörmann LLC, Montgomery IL, USA



Hörmann Flexon, Leetsdale PA, USA

Hörmann is the only manufacturer worldwide that offers you a complete range of all major building products from one source. We manufacture in highly-specialised factories using the latest production technologies. The close-meshed network of sales and service companies throughout Europe, and activities in the USA and China, make Hörmann your strong partner for first-class building products, offering “Quality without Compromise”.

GARAGE DOORS
OPERATORS
INDUSTRIAL DOORS
LOADING EQUIPMENT
HINGED DOORS
DOOR FRAMES