

// **NEW: ThermoFrame for improved thermal insulation**



Sectional Garage Doors

More convenience and security every day







Hörmann quality features	4
Benefits of the door type	6
Automatic sectional doors -	8
Only from Hörmann	10
Modernisation	12
Single and double-skinned steel doors	14
Design steel doors	24
Doors for on-site design	26
Timber doors	28
Design timber doors	30
Overview of all door styles	32
Glazings	35
Colours	36
Surfaces	38
Handles, locks	40
Side doors	42
Wicket doors	44
Garage door operators	46
Operator accessories	48
Safety features	52
Performance characteristics	54
Door sizes, fitting data	56
Programme overview	62

For more information on sectional garage doors and other high-quality Hörmann products, go to: **www.hoermann.com**.

Some of the doors shown are equipped with optional extras and do not always correspond to our standard models.

The colours and surface finishes shown are subject to the limitations of the printing process and cannot be regarded as binding.

All rights reserved. No part of this brochure may be reproduced without prior permission. Subject to changes.

Photos: Hörmann, K. Ortmeyer

“A good reputation must be earned.”

August Hörmann, Founder, 1886–1944



One name, one promise

Hörmann is brand quality you can trust

In line with the founder's philosophy, the Hörmann brand today is a true promise of quality. This family-owned company has over 75 years of experience in door construction and, with sales of approx. 15 million doors, is the market leader and no. 1 in Europe. This makes a Hörmann sectional door a reassuring purchase.

**Everything from a single source,
with uncompromising quality**

Made in Germany

All doors and operator components are developed and manufactured by Hörmann. Our highly qualified employees work intensively on new products, continual further developments and improvement to detail. Patents and unique products on the market are the result of this. Endurance tests under real conditions ensure mature series products with Hörmann quality.

Certified brand quality

At Hörmann, doors and operators are perfectly matched to each other and are approved and certified by independent established institutions for your safety. They are produced in accordance with the quality management system DIN ISO 9001 and fulfil all the requirements of European standard EN 13241-1. You can find out more on safety on pages 52-53.

Be environmentally aware

Hörmann uses environmentally-friendly processes for the colour coating of the doors. A high-tech regenerative exhaust air decontamination system substantially reduces energy requirements.

Long-term performance

Thanks to excellent technical solutions and uncompromising quality assurance, you receive a 10-year warranty on all sectional doors and 5 years on all Hörmann operators.



* The complete warranty conditions can be found under: www.hoermann.com



Space-saving

Sectional doors open vertically upwards and are suspended under the ceiling to save space. This constructional principle means you can make full use of the space inside and in front of the garage for parking.



Benefit from Numerous Advantages

Sectional doors fit anywhere and save space

There are many details that set a sectional door apart. All in all, you will enjoy the practical advantages every day: You can conveniently drive into your garage and have more space inside and in front of the garage. Treat yourself to this comfort and convenience.

Variable when fitting

The shape of the garage door opening is not of prime importance. Whether square, angled, with segmental or full centred arch – A Hörmann sectional door always fits.



Wider passage

- 1 With older up-and-over doors, driving in and out is often a matter of millimetres.
- 2 Sectional doors with a passage width extended by up to 14 cm also make it much easier to park modern, larger vehicles and SUVs.



Sealed all-round

- 3 Flexible and weather-resistant seals on all four sides of Hörmann's sectional doors keep out the wind and rain.

Additional intermediate seals

- 4 Double-skinned doors have additional high-grade intermediate seals between the individual door sections.



Bottom seal

- 5 Thanks to its large-sized profile lip, the bottom seal can easily accommodate slight irregularities in the floor.

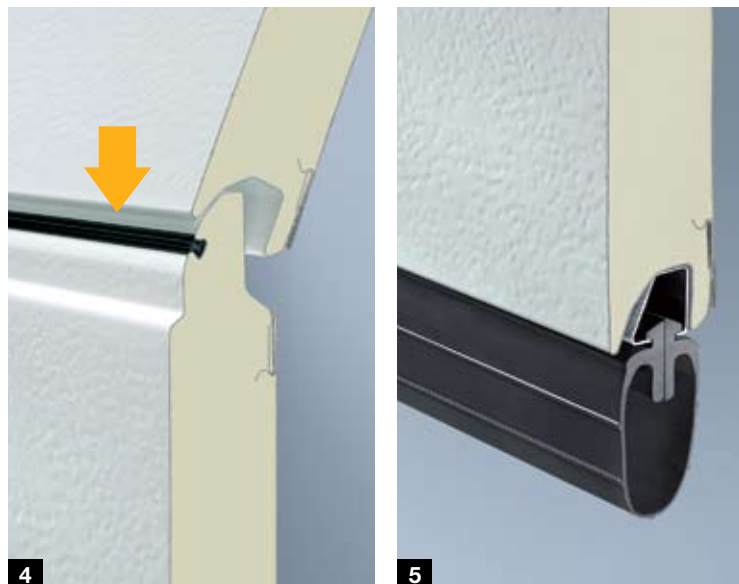



Hörmann automatic sectional doors have been tested and certified by TÜV in accordance with the TTZ directive “Break-in resistance for garage doors”. Doors with wicket doors and doors with glazing are an exception.

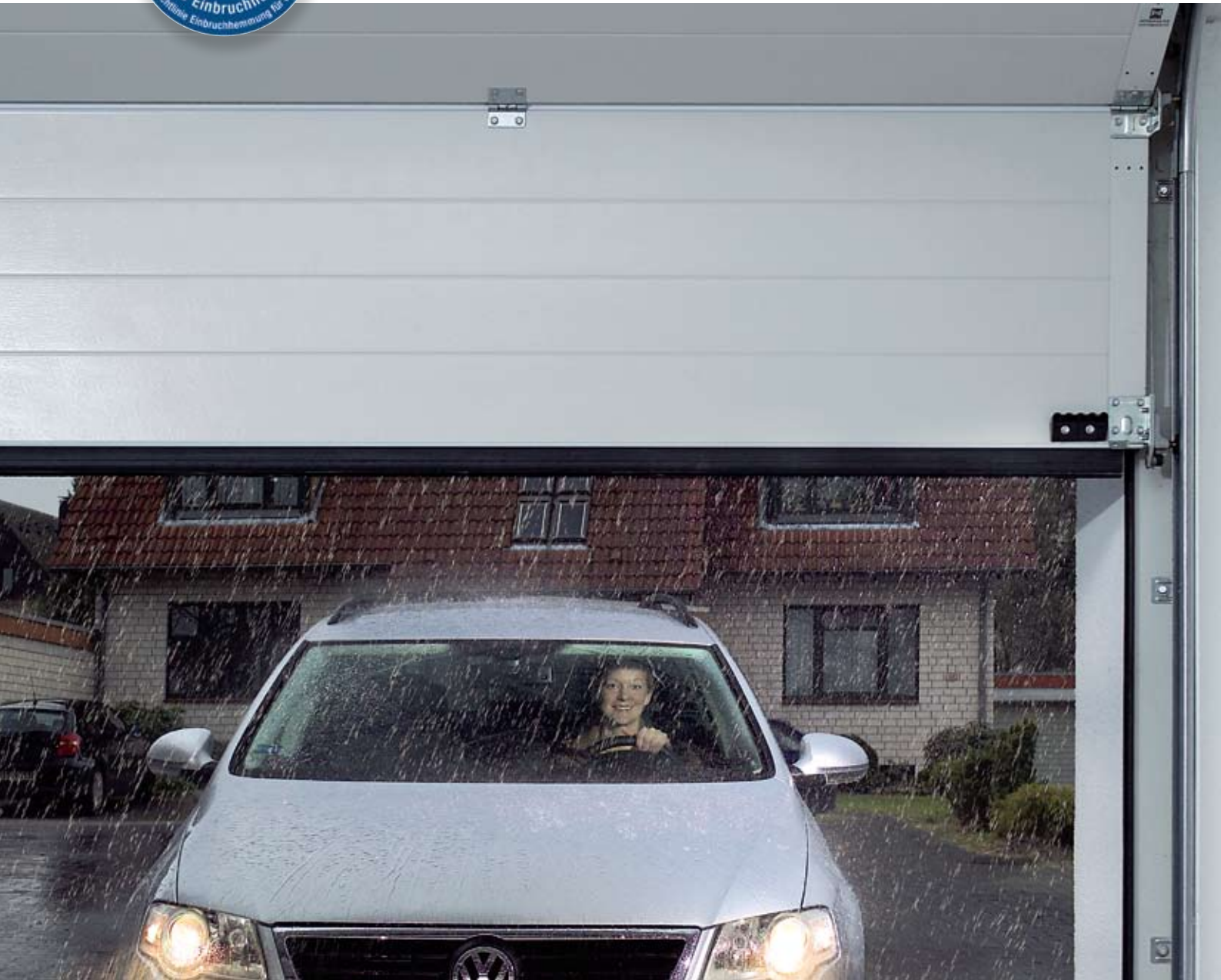

Automatically More Convenience

With garage doors and operators from Hörmann

You will feel it the first time you drive after dark or in nasty weather into your garage without having to get out and open the door: The decision for more convenience and safety was exactly right. Experience this and many other advantages, such as the automatic door latching only offered by Hörmann.

Fast, maintenance-free and automatically safe



Comforting security

Uninvited guests barely stand a chance with Hörmann's automatic sectional doors. Once the garage door has been closed, the door security kit automatically engages in the guide boom's stop, locking it immediately and making the door burglar-resistant. This door latching functions purely mechanically and, in contrast to competitor operators, continues to secure the door even when the power fails.



Also take a look at the video at:

www.hormann.co.uk



Into your garage faster

The up to 50% faster opening speed of Hörmann sectional doors in conjunction with SupraMatic garage door operators lowers the risk of accidents on busy streets and decreases stress. Compare the opening speed of a SupraMatic operator with common operators.



Also take a look at the video at:

www.hormann.co.uk



Individual, convenient operation

To ensure that you can easily and conveniently operate your automatic sectional door at any time, Hörmann also offers high-quality mobile and stationary accessories for all types of fitting situations: micro hand transmitters, code switches, finger-scans and even special solutions such as emergency batteries. See pages 48 - 51.



The design hand transmitter HSD 2 is set apart by its high-quality metal housing and an exclusive appearance. Winner of the **reddot design award**, it is sure to become the highlight of your key ring.



Constant Improvement for Your Home

The market leader has the innovations

With 75 years of experience in door production, Hörmann always strives to offer better products. This is where development and production departments come into play: They continually work to optimise the appearance, longevity and safety of the doors. Benefit from this expertise and from innovations exclusively by Hörmann.

Precise divisions

Hörmann garage doors are distinguished by equal-height sections with precisely aligned ribbing. If required, we can also provide you with convenient side doors with the same alignment. Further proof of the high production quality of Hörmann building products.



A harmonious overall appearance

The harmonious overall impression of a door is the result of many small details. This includes, for example, Hörmann's side frames with white Woodgrain to match the sectional doors as standard. Coloured doors or doors with Silkgrain or Decograin surface finishes come with frame coverings (as an optional extra) that match the surface and colour of the door leaf. Hörmann fascia panels also always match the door. This ensures that everything fits together.



Weather-resistant long-term protection

A non-brittle, 4 cm plastic frame shoe offers long-term protection against corrosion even with waterlogging, unmatched by competitor solutions. The frame shoe completely covers the frame in the area susceptible to rust – only this offers true long-term protection. Together with the door's bottom seal, the frame shoe makes a bottom edge that is visually appealing, as well. The frame shoe is not included as standard in LPU 40 XXL doors and aluminium sectional doors for on-site design.



Patent pending

With thermal break between the frame and the building structure.

A well insulated garage door is always recommended when the garage and the home are directly connected. To further improve the already high insulation values, especially of its LPU sectional doors, Hörmann has developed the ThermoFrame frame connection, a plastic profile that can be simply fitted together with the door frame. This creates a thermal break between the frame and the brickwork, improving the insulation by 15%. The optional ThermoFrame frame connection is available for all Hörmann sectional doors. See page 55 for more details.



ThermoFrame // NEW – Patent pending

* For an LPU sectional garage door with a door surface of 10 m².



Time to Modernise!

Standard sizes are the ideal solution

Many buildings exhibit the charm of days long ago. But modern garage doors provide extra convenience and security, whilst looking more attractive. At some point it is simply time to modernise your garage door. The best partner for this: Hörmann and its inexpensive standard sizes, especially for modernisation purposes.

Anyone renovating with Hörmann sees the benefits immediately

Modernise with inexpensive and quickly available standard sizes

Hörmann has many standard sizes that are exactly adapted to the up-and-over door to be replaced. These standard sizes will truly save you money and get you using your new automatic sectional door faster. Most of Hörmann's modernisation sizes are available directly from stock. And for the very rare case where a special size is needed, Hörmann can, of course, supply you with it at an attractive price.

Special anchors ease fitting

The special anchor is the solution for problematic fitting situations. Its flexible design compensates for e.g. irregularities in walls, makes it easier to fit the door in the opening thanks to a side fitting feature, and reduces the risk of cracks in the brickwork.

Matching, harmonious appearance

Visible gaps between the frame and opening can be easily covered with an optional retrofit fascia, doing away with the need for additional bricklaying and plastering work. The frame coverings come in the same colours and surface finishes as the door leaf.

Individual modernisation solutions

Hörmann can provide you with an attractive and proper solution for any fitting situation. For further information see the "Modernisation solutions for sectional doors" brochure under www.hormann.co.uk or just ask your Hörmann dealer.

Fast dismantling and fitting on the same day

Thanks to its easy-to-fit design, a Hörmann sectional door can be installed quickly.



Your Hörmann service partner can make modernisation easier than you think: From personal consultation to proper disassembly and environmentally-friendly disposal of your old door, as well as correctly dimensioned fitting.





Your taste is individual

Just like Hörmann's sectional doors

You want a door that fits with your exact specifications? Then Hörmann is the right place for you. Take your time to choose: the surface finish, colour and to have it with or without thermal insulation. Everything is possible. Of course, your Hörmann partner would be pleased to assist you personally.

Convenience and design It's your choice

Three panel thicknesses, one high level of quality

Hörmann's steel sectional doors come in three panel thicknesses, so one is certain to fit your individual requirements.

Single-skinned LTE doors are our least expensive version and are ideal for free-standing garages that do not need any thermal insulation.

Double-skinned EPU doors provide excellent thermal insulation and are the right choice if your garage adjoins the house or affords access to it.

Double-skinned LPU doors offer the best-possible insulation. Particularly recommended if you also use your garage as a hobby room or would like to lower your energy costs. Moreover, the 42 mm thick sections give the door greater stability and make for quiet operation.

Weather-resistant, lasting protection through hot-galvanized material with a high-quality polyester primer coating.



LTE 40
Single-skinned

EPU 40
Double-skinned
42/20 mm thick

LPU 40
Double-skinned
42 mm thick

Three attractive surface finishes with many colour options

For steel doors you have a choice of three attractive, weather-proof surface finishes: Woodgrain, Silkgrain or Micrograin.

The surfaces are perfectly protected against rust. Rain runs off and the grey haze brought about when the door is exposed to the environment is largely prevented.



Hörmann steel sectional doors and side doors with Woodgrain, Silkgrain and Micrograin surface finishes are available as standard in inexpensive Traffic white, in 15 equally-priced preferred colours as well as in about 200 colours based on RAL.

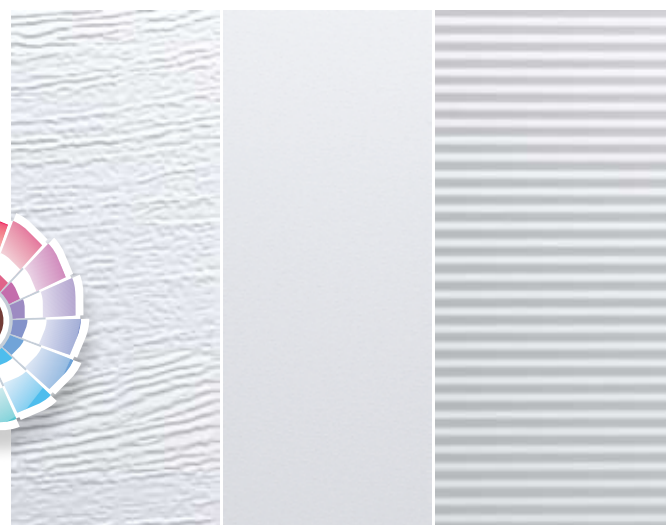

Woodgrain

Silkgrain

Micrograin

Six decor surfaces for a harmonious door design

The Decograin surface is available in five timber decor variants: Light Oak, Golden Oak, Dark Oak, Night Oak, Rosewood and the elegant Titan Metallic. This decor surface in dark anthracite is a very good match for Hörmann entrance doors that come in the colour CH 703.

The interiors of the doors are generally finished in Grey white (RAL 9002).

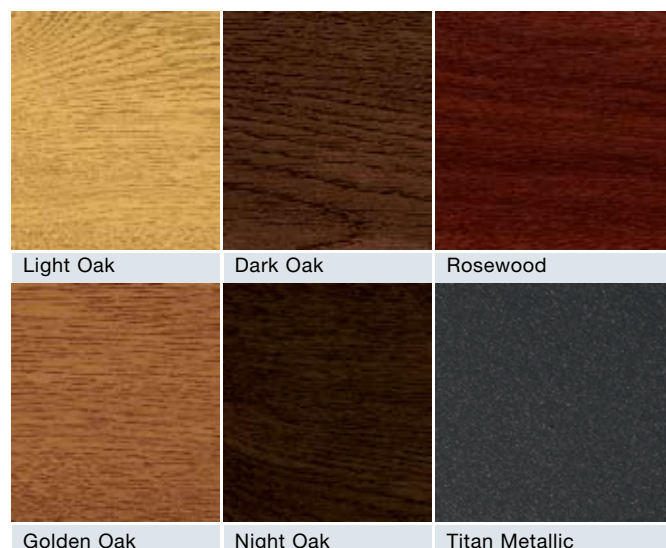

Light Oak

Dark Oak

Rosewood

Golden Oak

Night Oak

Titan Metallic



A Timeless Appearance

Slim ribbing

Slim, horizontal ribbing is the classic design for garage doors. Hörmann provides you with this S-ribbing in a premium quality, the visible proof of this being a uniform ribbed appearance. In contrast to the competition, the spacing between the ribbing is always uniform in Hörmann doors.

Single and double-skinned steel doors

LTE 40

LPU 40

S-ribbed



LTE 40
Single-skinned



LPU 40
Double-skinned door leaf
42 mm thick

Surface finishes and door sizes
(max. widths and heights in mm)



Woodgrain
Width 5000
Height 3000



Woodgrain
Width 5500
Height 3000

LPU 40 XXL up to max. 6500 mm width and 2250 mm height, see sizes and fitting details from page 56.
More information on surface finishes and colours from page 36.

LPU 40 sectional garage doors with ribbing are also available in extended standard widths of up to 6500 mm, at a maximum height of 2250 mm.



A homogeneous overall appearance thanks to precise, high-quality manufacturing with barely visible transitions between the sections. It pays to compare!



Tip

In addition to matching side doors, Hörmann also offers high-quality aluminium entrance doors that match many of the garage door designs. One example: the new surface Titan Metallic, similar to the entrance door colour CH 703.



Straightforward and Convincing

Medium ribbing

M-ribbing offers a matchless multitude of door types. Their clear lines make them particularly ideal for modern architecture.

Different colours and surface finishes help to emphasise the overall impression of your home.

Single and double-skinned steel doors

LTE 40

EPU 40/LPU 40

M-ribbed



LTE 40
Single-skinned

EPU 40
Double-skinned Door leaf
42/20 mm thick

LPU 40
Double-skinned door leaf
42 mm thick

Surface finishes and door sizes (max. widths and heights in mm)



Woodgrain
Width 3000
Height 3000



Woodgrain
Width 5000
Height 3000



Woodgrain
Width 5500
Height 3000



Silkgrain
Width 5500
Height 3000

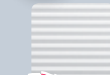

Micrograin
// NEW
Width 5500
Height 3000



Decograin
Width 5500
Height 3000

LPU 40 XXL up to max. 6500 mm width and 2250 mm height, see sizes and fitting details from page 56. More information on surface finishes and colours from page 36.

The Decograin surfaces with timber decor combine the advantages of a steel door with a natural timber look.



The high-grade surfaces are particularly easy to clean. Simply wash down with water and everything soon looks spick and span again.

Tip ✓ Whether you choose unobtrusive white or one of the many colour options, the new Micrograin surface, with its delicately lined profile, complements the clear look of L-ribbed doors.

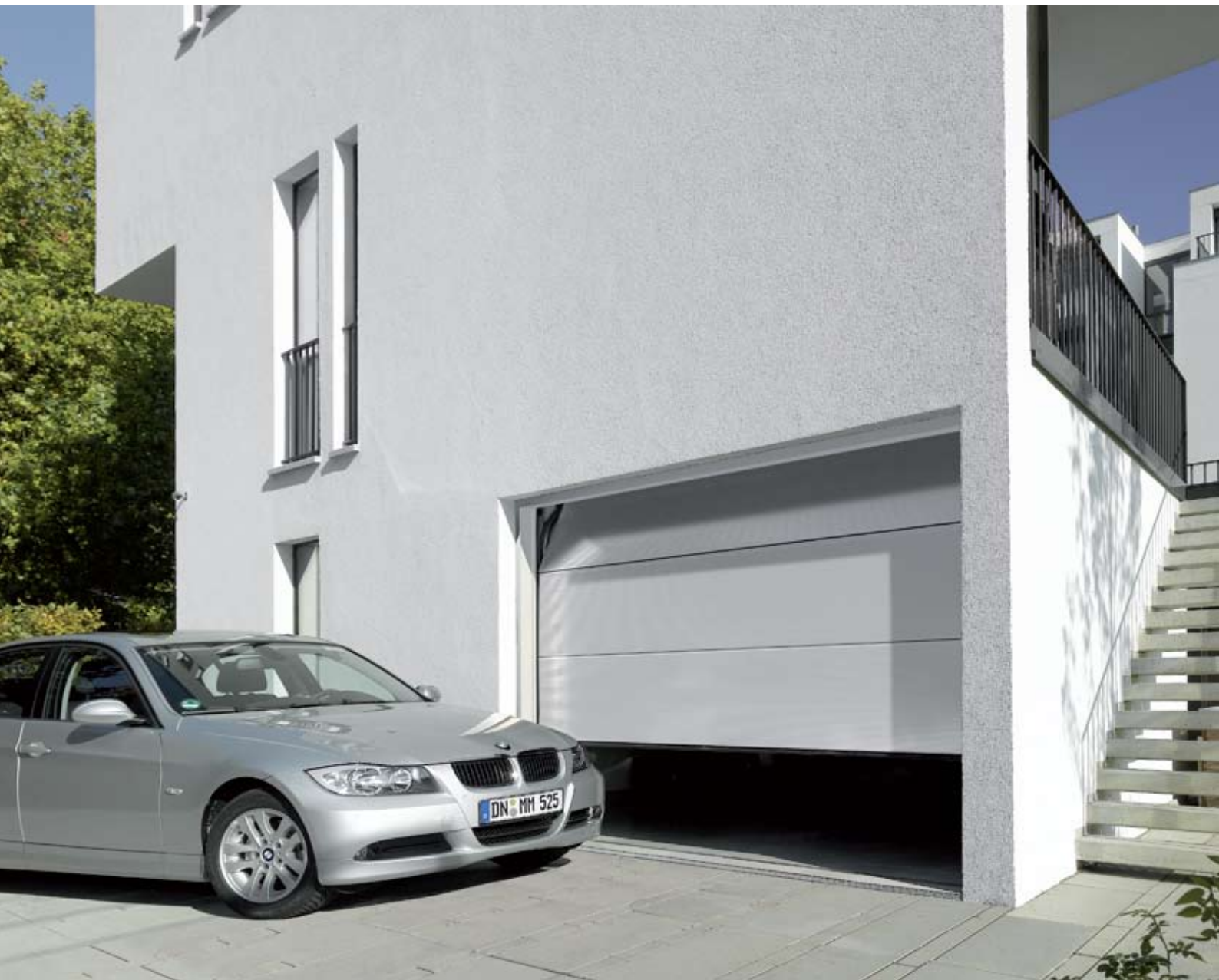

Perfect Elegance

Large ribbing

A special door for a special home. L-ribbing emphasises the unique elegance of unusual architecture. Of course, it also includes all of the convenience and security features of a Hörmann sectional door.

Double-skinned steel doors

LPU 40



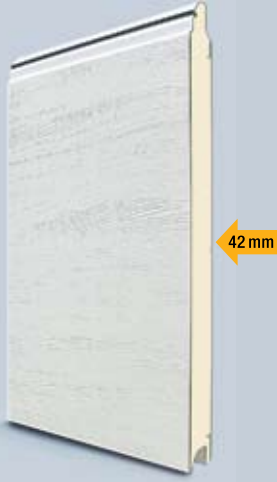

L-ribbed

LPU 40 sectional garage doors with ribbing are also available in extended standard widths of up to 6500 mm, at a maximum height of 2250 mm.



LPU 40
Double-skinned door leaf
42 mm thick

Surface finishes and door sizes (max. widths and heights in mm)

	Woodgrain Width 5500 Height 3000
	Silkgrain Width 5500 Height 3000
	Micrograin Width 5500 Height 3000
	Decograin Titan Metallic Width 5500 Height 3000

LPU 40 XXL up to max. 6500 mm width and 2250 mm height, see sizes and fitting details from page 56. More information on surface finishes and colours from page 36.



Distinct lines and colour for pleasing aesthetics, the Hörmann automatic sectional door for added convenience.



With its delicately lined profile, the new Micrograin surface complements the elegance of modern architecture.

Tip  Modernisation is extremely easy with Hörmann and less expensive than you think. After all, Hörmann offers many inexpensive modernisation sizes to replace your old garage door. This saves time and money.



Everything Is Possible

Narrow panelling

There is a panel design to fit almost any building style. Hörmann's S-panel offers many surface finishes and colour options. You are guaranteed to find the right door that suits your home perfectly.

Single and double-skinned steel doors

LTE 40

EPU 40/LPU 40

S-panelled

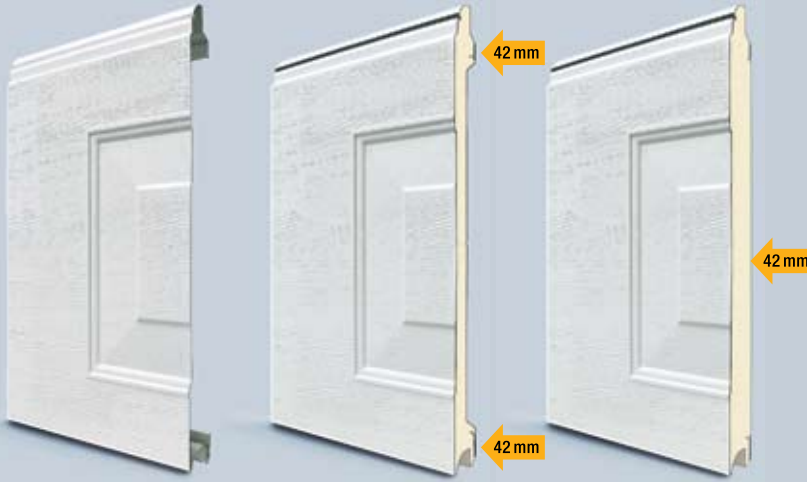

LTE 40
Single-skinned

EPU 40
Double-skinned
door leaf 42/20 mm thick

LPU 40
Double-skinned
door leaf 42 mm thick

Surface finishes and door sizes
(max. widths and heights in mm)



Woodgrain
Width 3000
Height 3000



Woodgrain
Width 5000
Height 3000



Woodgrain
Width 5500
Height 3000



Decograin
Width 5500
Height 3000

More information on surface finishes and colours from page 36.

The Sunrise Design glazing lends your garage door that personal touch. For more information on glazing, see page 35.



In the timber designs, the embossed texture of the UV-resistant Decograin surface on the exterior of the steel panels has all the detailed characteristics of timber.

Design garage doors to compliment your taste

Design and convenience are the hallmarks of these garage doors.



Stylish door combinations

Design steel doors

Stainless steel or glass design elements can be found everywhere in today's modern architecture. Hörmann offers high-quality design doors with a convincing appearance for this style, along with matching entrance doors.

Double-skinned steel doors

LPU 40

Design

L-ribbed



LPU 40
Double-skinned
door leaf 42 mm thick

Surface finishes and door sizes
(max. widths and heights in mm)



Silkgrain
Width 5500
Height 3000

More information on surface finishes and colours from page 36.

Harmonious aligned appearance

A perfectly matched appearance from Hörmann: garage door and entrance door ribbing is harmoniously aligned.



Matched with the architecture of your home: design sectional door style 457 and Hörmann entrance door system style 188 TP.

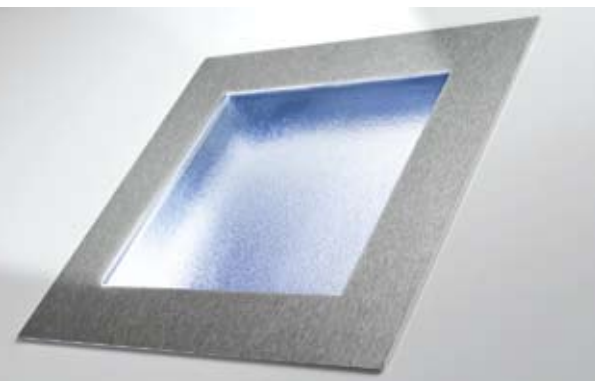

The styles 461, 462 and 469 extend the range of the design steel doors by incorporating high-quality glazing elements.

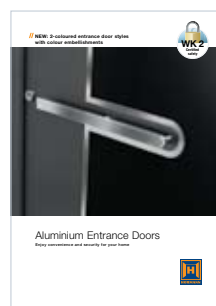

All design doors can be found in the overview on page 33, design entrance doors can be found in **Hörmann's Entrance Doors** catalogue, as well as on the Internet under www.hormann.co.uk.

Tip  With the new aluminium sectional door, your garage door is seamlessly integrated into the overall design of your home.



Do It Your Way

Sectional garage doors for exclusive facade designs

With the aluminium sectional door, you can consistently maintain your personal architectural style. The design concept unites the facade and the door, ensuring a harmonious, clear form. This sectional door optimally meets even the most exclusive demands.

Aluminium sectional door for on-site design

You provide the idea – we advise you

Our high-quality aluminium sectional door is as versatile as today's facade covering options. The door can be clad in timber, metal, ceramic, plastic and many additional materials, according to your wishes and requirements.

Individuality needs good planning, too.

During the planning phase, many points must be clarified and coordinated: cladding thickness (max. 46 mm), weight of the cladding per m², the gap dimension between the elements (min. 20 mm) that must be maintained and the available door section heights. This is why each door/facade combination must be individually planned.

We would be glad to advise you!



The door basis for facade cladding is a Hörmann industrial sectional door ALR 40, an aluminium frame construction with panel infill. Industrial doors are especially stable and designed for reliable long-term function.

Once it is installed and cladded, the garage door is an integral part of the continuous facade.

Note: The track application for the door is based on track application L for XXL sectional doors. For more information on tracks, see page 59.



Tip Add comfort and convenience to your beautiful timber garage door by equipping it with a precisely matched garage door operator. We recommend the powerful Hörmann SupraMatic P.



Natural Charm

Solid timber doors

Many people simply must have timber. Hörmann can help you with this: Solid timber doors with ribbing or panels emphasise the flair of a natural lifestyle. Every one of these doors comes with all of Hörmann's usual comfort and security features.

Doors with solid timber infill

LTH 40

S, M, L-ribbed

V-panelled



LTH 40
S, M and L-ribbed

LTH 40
V-panelled

Nordic Pine

Nordic Pine is a light-coloured softwood with predominantly straight graining. Heart shakes, individual resin pockets, spiral graining and the yellowish brown "knots" are natural characteristics of the wood.

Hemlock

Hemlock is a greyish white to light-greyish brown softwood with predominantly straight grain, brown mineral stripes along the grain and with bark pockets.

Timber types and door sizes
(max. widths and heights in mm)

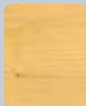

Width 5000
Height 3000



Width 5000
Height 3000



Width 5000
Height 3000



Width 5000
Height 3000



If you wish to site-paint your Hemlock panelled door in light colours, we supply it pre-treated with a wood preservative and primed white at no extra cost.

Hörmann solid timber doors are pre-treated at the factory to protect them against insect and fungal attack. To protect it from weathering and retain its beautiful appearance, please treat the timber with a wood preservative.

On request you can receive style 405 (shown below) with double-leaf door fittings and decorative handles for on-site mounting. There are two versions to choose from: exclusive fittings or standard fittings.



Individual Flair

Design timber doors

Hörmann's solid timber doors also come with numerous design elements. High-quality materials such as natural stone, fittings for a hinged door look, and decorative handles all ensure an exquisite ambience. For a practical and perfect match, try an identical side door.

Doors with solid timber infill

On request, each garage door can be supplied with a matching side door (shown above). Where garages do not have a second access door, we recommend equipping them with an emergency release lock, see page 41.

LTH 40



LTH 40
Individual styles
Nordic Pine



LTH 40
Individual styles
Hemlock

Timber types and door sizes
(max. widths and heights in mm)



Width 5000
Height 3000



Width 5000
Height 3000

You will find an overview of all the design timber garage door styles on page 34.



Design your own door.

For example, displaying your initials, house number or your favourite motif. A simple drawing as a template is enough. A computer-aided precision mill exactly transfers your draft to the wooden door panels. The result is your very own customised garage door in a unique design.

Of course, you can receive a side door with a matching appearance to your individually designed garage door.



An example of individual milling: Modern, straight-forward and matching the architecture.

An overview of the steel styles

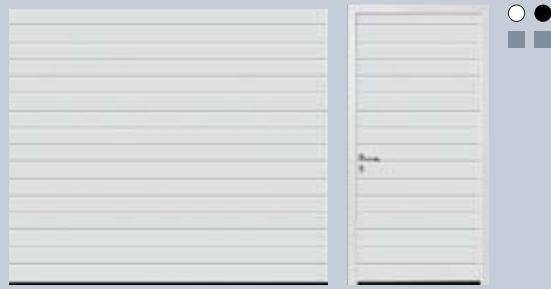

S-ribbed

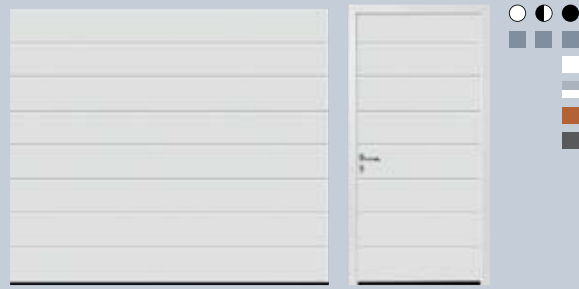

M-ribbed

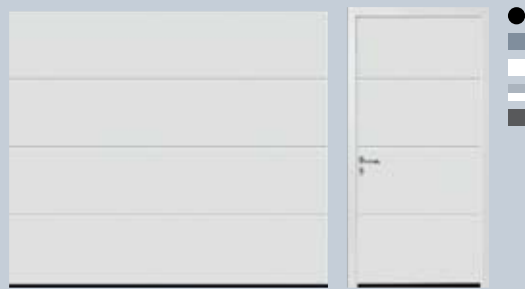

L-ribbed

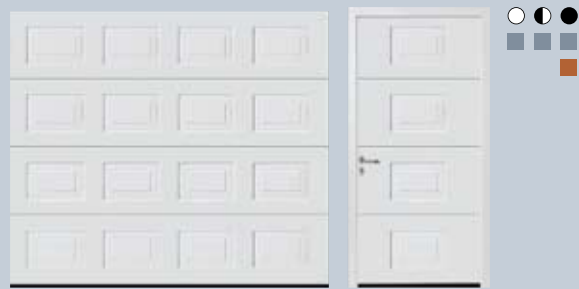

Panel

Door leaf thicknesses

- LTE, single-skinned
- EPU, double-skinned 42/20 mm
- LPU, double-skinned 42 mm

Surface finishes

- Woodgrain
- Silkgrain
- Micrograin
- Decograin (timber design)
- Decograin Titan Metallic



More about the many colour options of double-skinned doors on pages 36-37.

Glazing elements

- These design variants for steel doors come with high-quality glazing elements in stainless steel frames. For a detailed illustration, see page 25.

An overview of the steel design styles



Style 450

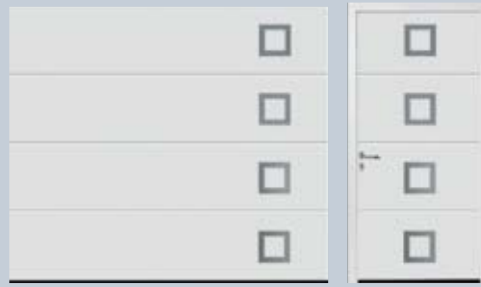

Style 451, style 461 (not shown)

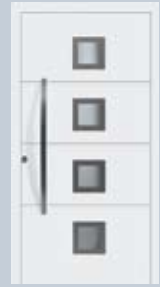

Entrance door style 173 TP



Style 452, style 462 (not shown)



Style 454, centre arrangement



Entrance door style 693 TP

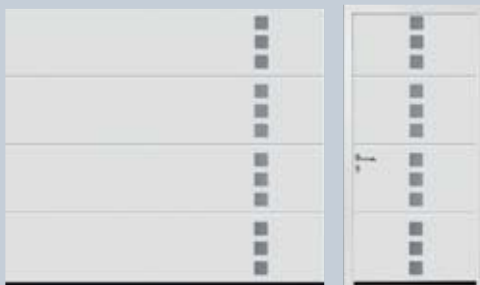

Style 456

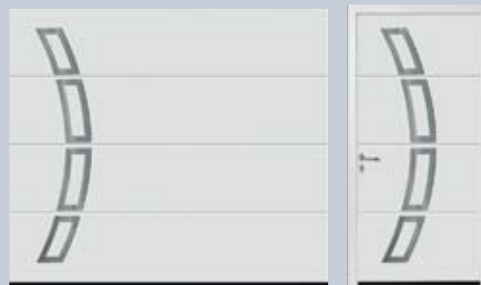

Style 457, left arrangement, mirrored style



Entrance door style 188 TP



Style 458

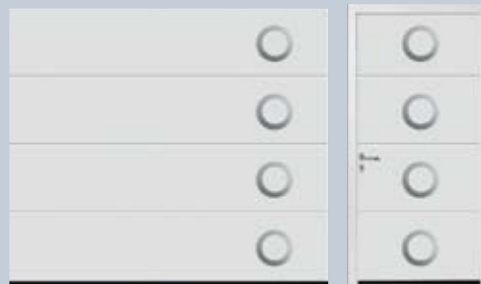

Style 459, style 469 (not shown)

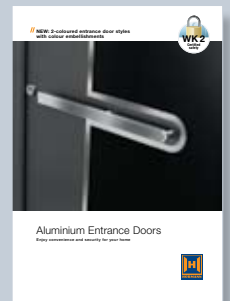

Get inspired. Hörmann's specialised brochure on aluminium entrance doors includes many attractive designs.

Style elements for steel design doors can be arranged on the left and right or in the centre. Mirrored versions are also possible.

An overview of the solid timber styles

The solid timber styles are available in the wood types Nordic Pine (illustrated) and Hemlock.



S-ribbed



M-ribbed



L-ribbed



V-panelled

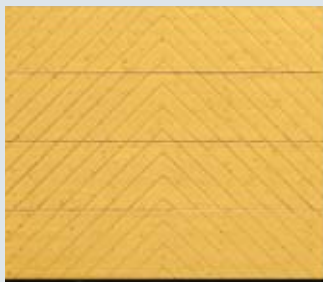

Style 401



Style 405



Style 404, with natural stone



Tropical-green



Multicolour-red



Balmoral-rosso



Style 403

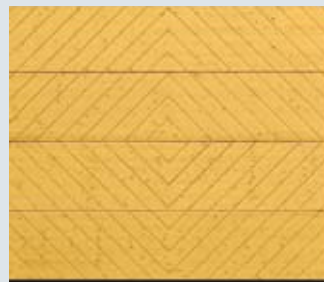

Style 402



Style 403, with natural stone

In styles 403 and 404, natural stone is used as an attractive design feature. Variations in colour and structure are a natural characteristic.



Style 404

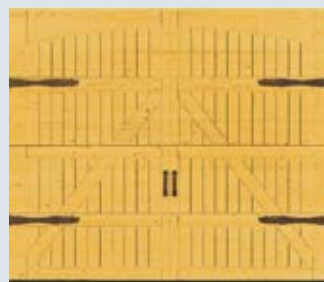

Style 405, with optional double-leaf door fittings for on-site mounting

The colours and surface finishes illustrated are subject to the limitations of the printing process and cannot be regarded as binding. Please consult with your local Hörmann specialised dealer.

Glazing adds a special touch

Incorporate glazing to give your garage an individual look, matched to the windows, entrance door and the architectural style of your home.



Glazing for ribbed styles

Classic glazing

Overall frame dimension 620 × 270 mm (M0, M2) and 1004 × 270 mm (L0)



Glazing type D

Overall frame dimension 680 × 210 mm



For all garage door types and side doors with ribbed appearance, in the Woodgrain and Decograin surface finishes. Glazing frame: black or white plastic, on request in colour of door. Glazing: Depending on the door type as single or double synthetic panes, clear or crystal-structure. Clear view: 602 × 132 mm.

Aluminium frames



For all garage door types and side doors with ribbed appearance, in the Woodgrain and Decograin surface finishes. Glazing frame made of anodised aluminium profiles in accordance with DIN 17611, surface anodised in natural colour E6/C0 (formerly E6/EV1), or in door colour on request. Available as standard profile (NF) or thermal break profile (WF). Single or double synthetic panes, clear or crystal-structure and expanded mesh.

Classic and Sunrise glazing for panelled and ribbed styles

Classic glazing

Overall frame dimension 395 × 270 mm

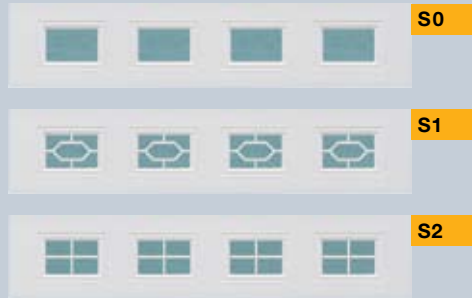

Presentation of the classic glazing shown on the left using the example of a 2500 mm wide door.

Sunrise glazing

Overall frame dimension 395 × 270 mm



The style S10 is also available as Double S50 (2 × S10). Width same as style S60.

Classic and Sunrise styles

Glazing frame and decorative rails: Plastic, standard colour white, on request in garage door colour. With Decograin garage doors the frame is supplied in a paint finish to coordinate with the colour of the door.

Glazing: Depending on the door type as single or double synthetic panes, clear or crystal structure.

Glazing for timber styles with V panelling

V-panel glazing

Overall frame dimension depending on the panel or door size

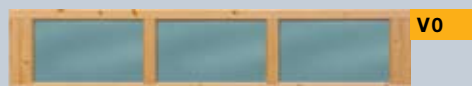

Note:

Glazings not possible in the two bottom door sections.

The surfaces are perfectly protected against rust. Rain runs off without leaving any streaky marks thanks to the use of hot galvanised material and a high-quality polyester primer-coating* on both sides. A grey haze from air pollution is largely prevented.



A Question of Taste

Colours and surface finishes to choose

Regardless of the colour you select – classic white or one of the many preferred colours, you can always choose between three surface finishes: Woodgrain, Silkgrain and Micrograin.

Woodgrain surface finish

On this robust surface with an authentic sawn timber look, minor scratches can be repaired without leaving any visible sign of damage.



Traffic white

RAL 9016

Silkgrain surface finish

This silky-smooth, elegant surface particularly fits well with modern architecture.



Micrograin surface

This surface features a wave profile that is embossed into smooth steel, producing attractive light and shadow effects.







In competitively-priced Traffic white as standard





The single and double-skinned steel doors are supplied as standard in Traffic white.





15 equally-priced preferred colours

Double-skinned garage doors and side doors are additionally available in 15 inexpensive preferred colours and in around 200 colours from the RAL colour chart.



	White aluminium	RAL 9006
	Terra brown	RAL 8028
	Clay brown	RAL 8003
	Ochre brown	RAL 8001
	Window grey	RAL 7040

	Light grey	RAL 7035
	Stone grey	RAL 7030
	Anthracite grey	RAL 7016
	Fir green	RAL 6009
	Moss green	RAL 6005

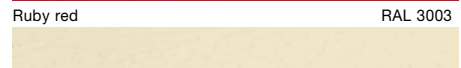
	Pigeon blue	RAL 5014
	Steel blue	RAL 5011
	Sapphire blue	RAL 5003
	Ruby red	RAL 3003
	Light ivory	RAL 1015

White and coloured doors are generally supplied in Grey white (RAL 9002) on the inside of the door.

* For more information, please see the fitting instructions under www.hormann.co.uk.

**With the exception of pearl-effect, fluorescent and metallic colours. Dark colours should not be used for double-skinned steel doors that are exposed to the sun, as possible section deflection may restrict the door's function.

The colours and surfaces shown are subject to the limitations of the printing process and cannot be regarded as binding. Please consult with your local Hörmann specialised dealer.



With its unique embossed graining, the UV-resistant synthetic foil coating on the outside of the steel sections conveys the authentic character of timber. The special surface protection on Decograin® doors preserves the appearance of the door over a long time.



Six charming styles

Decograin surfaces

Detailed, natural timber look or Titan Metallic elegance, combined with all the advantages of a steel door: The Decograin surface offers a charming appearance in six modern decors.

Decograin Light Oak
Light, warm oak design



Decograin Dark Oak
Walnut-coloured oak design



Decograin Rosewood
Mahogany-coloured timber design



Decograin Golden Oak
Medium-brown, golden yellow oak design

Decograin Night Oak
Dark, intense oak design

Decograin Titan Metallic
Anthracite with a metallic effect

Decograin steel doors are generally supplied in Grey white (RAL 9002) on the inside of the door.

The colours and surface finishes shown are subject to the limitations of the printing process and cannot be regarded as binding. Please seek the expert advice of your Hörmann specialist dealer.

The door handle not only needs to look good,
it needs to give a good grip too.



Completely Under Control

Whether manually operated or automatic, Hörmann sectional doors open safely and easily

With these handles, developed by designers and safety experts, you hold a quality in your hand that, in this form, no other manufacturer can match. Select the handle of your choice from seven shapely variants to match your door and entrance and add it to your door order. Your Hörmann specialist dealer will be more than happy to fit it for you.

**A beautiful handle places special accents
Select the handle of your choice**



Black plastic



Cast aluminium, white (similar to RAL 9016)



Silver cast aluminium



Brass cast aluminium



Brushed stainless steel



Polished stainless steel



Brown cast aluminium

The flush-fitting cylinder can also be mastered with other locks in your home.

Safer and more burglar-proof with automatic and manually operated Hörmann sectional garage doors.



For garages without a second access door, we offer you the following options to open your automatic garage door from the outside in an emergency (e.g. in the event of a power failure).

For automatic sectional doors where no handle is desired, we recommend an emergency release lock (top illustration) with round cylinder (cannot be mastered with other locks in your home).

Or choose one of the seven handles shown, including lock (can be integrated in the master key system).



Manually operated sectional doors are more burglar-proof thanks to latch locking

In this lock (top illustration), a sturdy automatic latching spring disc grips round a solid steel bolt to securely retain the door. Intruders don't stand a chance!

Tip  The double-skinned infill of the side doors is PU-foamed and available in the surface finishes Woodgrain, Silkgrain, Micrograin or Decograin, matching the garage doors.



Not a Side Line

The side door to match your garage door

A side door matching the appearance of the garage door simply makes your home look harmonious. This is why Hörmann offers matching side doors for all its garage doors. The perfect complement to a Hörmann sectional door.

A matching side door for every garage door

Block frame

Corner frame



We supply steel side doors in three different versions.

**Profile type 1
(narrow surround) with
aluminium block frame**

Depending on the height of the door, variable handle position between 898 and 1268 mm from FFL. Recommended for fitting behind the opening, opening inwards.

**Profile type 2
(broad surround) with
aluminium block frame**

Lever height set at 1050 mm from FFL. For fitting behind or in the opening, opening inwards or outwards. For panelled side doors, fitting behind the opening only.

**Profile type 3
(narrow surround) with
aluminium corner frame**

Depending on the height of the garage door, variable handle position between 898 and 1268 mm from FFL, for fitting in front of the opening. The corner frame is also available with profile types 1 and 2, for fitting behind the opening.

Door leaf frame and fascia frame on side doors are made of weather-proof aluminium extrusions (depth: 60 mm) with all-round seals.

Surface finishes for steel doors

Woodgrain, Silkgrain, Micrograin, Decograin



Types of timber

Nordic Pine, Hemlock



Lever handle set

As standard with plastic lever handles on both sides or on request with lever/knob handle set. Available in all material versions, matching the garage door. See page 41.

3-point security locking

Optional equipment for profile type 2 with latch, bolt, 2 locking hooks and security rose escutcheon class 2 according to DIN V EN V 1627-1630.

Hörmann side doors are supplied ready-to-fit with profile cylinder mortise lock, round handle/lever handle set with oval roses and on models with block frame with 3-way adjustable hinges.



Decograin side doors with block frames or corner frames come with identical surfaces for the frame, subframe and door to create a harmonious impression.

Tip  A wicket door gives you easy access to everything in the garage: gardening equipment, bicycles, wheelbarrows ...



Convenient for Day-to-Day Use

The wicket door with trip-free threshold

Sometimes it's the small things that make the greatest difference: For example, if you want to fetch your bike without having to open the garage door, you'll soon realise the convenience of a wicket door with a trip-free threshold. Unique and only from Hörmann!

A wicket door with trip-free threshold offers unhindered access to the garage. Available for garage doors up to 4000 mm wide.



The panel divisions may not be matching for panelled doors with and without wicket doors with the same width.



On request, Decograin wicket doors can be supplied with the frame painted to match the colour of the decorative finish.



Hörmann wicket door with flat stainless steel threshold, 10 mm at centre and 5 mm at the corners. It reduces the risk of tripping up and it's easier to wheel things through.

The aluminium door frame is anodised as standard in a natural finish and is also available in the door colour.

It goes without saying that there is no risk of trapped fingers – neither in the area of the wicket door frame nor over the entire door leaf – thanks to Hörmann's patented finger trap protection. The top garage door section, also in the wicket door area, comes with a continuous lintel seal.

Fittings: overhead door closer, mortice lock with profile cylinder, lever handle set (offset/flat) with oval rose escutcheons.

A version with hold-open device is also available on request. This makes passage e.g. with a bicycle even easier, also for children.

Note: To further increase the safety of your door with wicket door and trip-free threshold, we recommend using the optional leading photocell VL2.



Manually-operated garage doors incorporating a wicket door do not have an outside handle. They are locked from the inside.



Wicket doors generally open outwards.

When a garage door is planned with a wicket door, accurate measuring and proper fitting by your Hörmann specialist dealer are extremely important!



Up to 50% faster opening speed
with the SupraMatic operator



Reliable, Safe and Maintenance-Free

ProMatic and SupraMatic – Hörmann's high-quality garage door operators

Hörmann's boom-guided operator technology is a patented system with numerous advantages: Your garage door will run reliably and quietly, and not require any maintenance. A break-in-resistant, automatic door latching also protects you from unwanted visitors.

Operator variants

ProMatic operators



The good-value starter model as an introduction to Hörmann's premium quality.
Opening speed: max. 14 cm/s.

ProMatic

For doors up to 5000 mm wide (max. 10 m² door leaf surface)
Pull and push force: 500 N
Peak force: 650 N

ProMatic P

For doors up to 5500 mm wide
Pull and push force: 600 N
Peak force: 750 N

ProMatic Akku

For garages not connected to the mains supply and doors up to 3000 mm wide (max. 8 m² door leaf surface)
Pull and push force: 350 N
Peak force: 400 N



An optional solar module recharges the battery.

SupraMatic operators

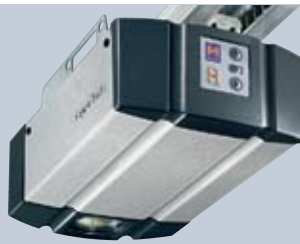

The supra-fast operator with an array of additional functions.
Opening speed: max. 22 cm/s.

- Halogen lighting can be switched on/off separately
- Additional opening height for a well-ventilated garage

SupraMatic E

For doors up to 5500 mm wide
Pull and push force: 650 N
Peak force: 800 N

SupraMatic P incl. photocell

For doors up to 5500 mm wide, heavy timber doors and doors with wicket doors
Pull and push force: 750 N
Peak force: 1000 N

SupraMatic H

For collective and underground garages. Your Hörmann dealer would be pleased to assist you.

SupraMatic HD

For LPU 40 XXL doors,
Pull and push force: 1000 N
Peak force: 1200 N

Proven operator technology

- 868.3 MHz radio frequency with stable range
- 4-button mini hand transmitter with security code from more than 1 trillion options
- Integral receiver
- Automatic locking provides effective protection against forced opening
- On encountering an obstruction, a reliable automatic cut-out stops the door immediately
- A "soft" start and "soft" stop minimises wear and tear on both the door and operator
- Patented toothed belt is maintenance-free
- Emergency release from inside
- Easy to install – everything is precisely prepared

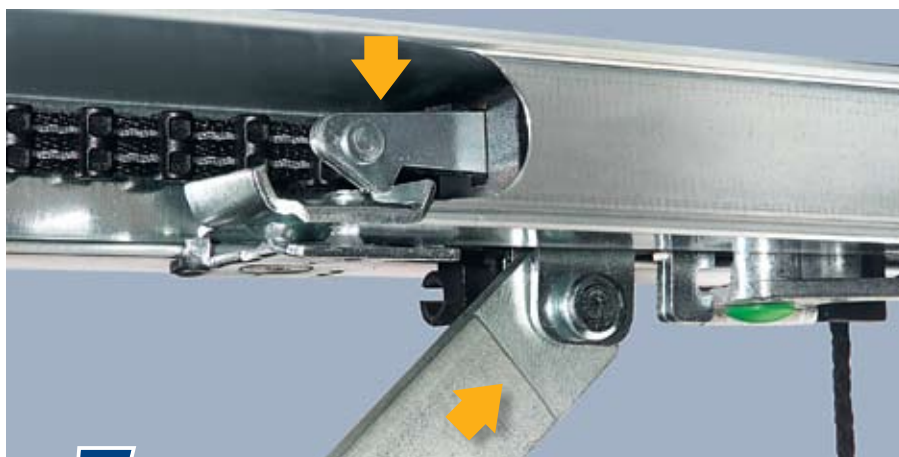

Only from Hörmann

Automatic door locking

The door automatically locks on closing, making it impossible to lever it open. This unique automatic latching system is a mechanical device and therefore remains fully functional even in the event of a power failure.



Also take a look at the video at: www.hormann.co.uk.

* The complete warranty conditions can be found under: www.hoermann.com.

The design hand transmitter HSD 2 is set apart by its high-quality metal housing and an exclusive appearance that has received the **reddot design award**. The highlight on your key ring.



reddot design award



Award-Winning Accessories

Portable and handy

Hörmann's intelligent accessories include everything you need to open and close your door. For your key ring, for your car and, above all, for your personal mobile convenience.

Mobile convenient accessories



With Hörmann, everything fits together. Using the same hand transmitter you use to operate your garage door, you can also open an entrance gate that is equipped with a Hörmann operator.



Mini hand transmitter HSM 4 for four functions



Micro hand transmitter HSE 2 for two functions, incl. key ring



Hand transmitter HSP 4 with button lock-out, for four functions, incl. key ring



Hand transmitter HS 4, for four functions



Hand transmitter HS 1, for one function



HSD 2-A aluminium look, for two functions



HSD 2-C glossy chrome, for two functions



Always on hand in your car – inconspicuously located in the cigarette lighter. The inexpensive alternative to a remote control system integrated in the car.



Hand transmitter HSZ 1 for one function



Hand transmitter HSZ 2 for two functions

Ask your specialist dealer about the radio set HF 22, which includes an HSZ 2 and receiver HET 2 (also suitable for other makes and operators without 868.3 MHz radio frequency).

With proven Hörmann technology

- Protection against unauthorised use with a trillion possible radio codes
- Stable range thanks to 868.3 MHz frequency
- Homelink-compatible (version 7)
- Impact-resistant due to a permanently fixed antenna
- Simple transmission of coding between hand transmitters



Tip  Families with children particularly appreciate extra safety. A photocell installed in the garage opening immediately stops the door before it encounters an obstruction. An extra bit of protection for a minimal cost.



High-Tech for Safety

Reliable accessories for your home

Hörmann continually works to develop intelligent and individual solutions for your day-to-day convenience. You can rely on high-tech concepts such as the finger-scan that enables you to open your door using your fingerprint.

Stationary convenience and security accessories

Radio code switch with illuminated buttons

Hörmann radio code switches are available in two versions. They are easy to install because you do not need to lay any cables. The combination code you enter is transmitted by radio.

The inexpensive FCT 3b with three functions has a hinged panel for protection.

The convenient FCT 10b with ten functions features a weather-resistant keypad.

Code switch with illuminated buttons

With the CTR 1b (for one function), you simply enter your personal code. The CTR 3b has three functions.

Code switches

CTR 1d/CTR 3d (matching the FCT 3b) with a protective cover, without illuminated keypad, for one/three functions.

CTV 1/CTV 3

(not shown) with a keypad protected against vandalism, identical function as the CTR 1b/CTR 3b.

Transponder key switch

Simply hold the coded transponder key approx. 2 cm in front of the reader to activate any function. Two keys are included, further keys are available on request. The convenient TTR 100 can recognise up to 100 keys, and the TTR 1000 up to 1000 keys.

Finger-scan Radio finger-scan

Your fingerprint is all you need to safely and conveniently open your garage door. The second function can be used to .g. operate an additional garage door, an entrance gate or the entrance door. The finger-scan is available in two versions, as an FL 12 or FL 100 to store 12 or 100 fingerprints, respectively.

Also available as the radio finger-scan FFL 12 for up to 12 individual fingerprints.



Radio code switch
FCT 3b with
protective cover



Radio code switch
FCT 10b



Code switch
CTR 1b/3b



Transponder key
switch
TTR 100/1000



Finger-scan
FL 12/FL 100



Radio finger-scan
FFL 12



Key switch

For recessed or surface mounting in two versions, each with three keys.

ESU, ESA

STUP, STAP

Internal push button with illuminated button

With the IT 1b, you open your door via the illuminated button. The IT 3b for SupraMatic operators additionally offers separate control of the operator light and the possibility of switching the operator off permanently, for instance when you are away on holiday.



IT 1b



IT 3b

Radio internal push button

With the FIT 2, you can actuate two operators or operator functions. Operation is via impulse buttons or connected key switches (optional extra), which can be switched off at the FIT 2 unit, for instance, during holiday times.



FIT 2

Photocell

A photocell is simply a must with automatic doors. They are quickly fitted and substantially increase safety at an affordable price.



EL 101



Technically mature

Operating comfort with the highest security

The safety of the garage door users has always been top priority for Hörmann. And Hörmann sets the standards for this with its innovative solutions. This has been proven time and time again through numerous Hörmann patents. And this provides you and your family with safety during daily use.

Safety features according to EN 13241-1



Tension spring technology with spring-in-spring system

Hörmann sectional doors with double tension springs and double cables per side safeguard the door leaf against crashing to the floor. Thanks to the patented spring-in-spring system, broken springs are prevented from flying out and causing injuries.

Sectional doors up to 3000 mm wide and 2625 mm high include the proven tension spring technology as standard.

Hörmann patent



Torsion spring technology with integrated spring safety device

Hörmann sectional doors incorporate galvanised torsion springs on both sides featuring a patented spring safety device. In the event of a spring breaking, they arrest the door immediately, thereby preventing the door leaf from crashing to the floor. Larger sectional doors and doors with integral wicket door or garage doors with solid timber infill feature torsion spring technology.

Hörmann patent



Secure guidance of the door in safety tracks

Adjustable, patented track rollers, sturdy roller holders and safety tracks ensure that there is no danger of the door "derailing". The door sections are safely parked under the ceiling.

Hörmann patent



Finger trap protection on the inside, outside and on the hinges

The unique form of the door sections eliminates trap points, both between the sections and on the hinges. This reliable finger trap protection is only offered by Hörmann.

Hörmann patent



Trap guard on the side frame

With Hörmann the frames are completely closed from top to bottom. There are no gaps between the door leaf and frame in which fingers could get trapped!

Anti-fall safeguard Trap protection

Hörmann sectional doors are tested and certified in accordance with the high safety requirements of European standard 13241-1, not only on their own but also in combination with operators. It would be hard to find a safer sectional door. It pays to compare!





365-day reliability

Tested and certified

Brand quality down to the smallest detail makes all the difference and ensures your safety. After all, you want to enjoy your door for a long time to come. This is why Hörmann's sectional doors fulfil the strictest standards with thoroughly convincing values.

Performance characteristics according to European standard 13241-1

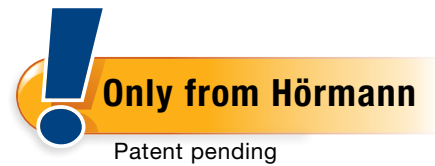

At Hörmann, the four important characteristics of thermal insulation, acoustic insulation, tightness and sealing, and wind load for garage doors are tested and certified. These are important for your choice of door over and above the mandatory safety requirements. For example: thermal and acoustic insulation for the garage, sealing against adverse weather effects and resistance to wind pressure in particularly windy regions.

Thermal insulation

Double-skinned steel doors 42/20 mm	
Section	U=1.00 W/m ² K
Door leaf	U=1.36 W/m ² K
Fitted door ¹⁾	U=1.80 W/m ² K
Double-skinned steel doors 42 mm	
Section	U=0.50 W/m ² K
Door leaf	U=0.90 W/m ² K
Fitted door ¹⁾	U=1.30 W/m ² K
Single-skinned steel doors	
Door leaf	U=6.00 W/m ² K
Fitted door ¹⁾	U=6.40 W/m ² K
Doors with solid timber infill	
Door leaf	U=2.50 W/m ² K
Fitted door ¹⁾	U=2.90 W/m ² K

Acoustic insulation

Single-skinned steel doors	R=approx. 20 dB
Double-skinned steel doors 42/20 mm	R=approx. 21 dB
Double-skinned steel doors 42 mm	R=approx. 22 dB

Sealing

Air	Single-skinned steel doors	Class 0 ²⁾
	Double-skinned steel doors ribbed (not L-ribbed)	Class 2
	Double-skinned steel doors panelled and L-ribbed	Class 3
	Doors with solid timber infill	Class 0 ²⁾
Water	Single-skinned steel doors	Class 0 ²⁾
	Double-skinned steel doors	Class 3 ³⁾
	Doors with solid timber infill	Class 0 ²⁾

Wind load

Single-skinned steel doors	Class 2
Double-skinned steel doors 42/20 mm	Class 3
Double-skinned steel doors 42 mm	Class 3
Doors with solid timber infill	Class 3

Higher wind load classes on request

¹⁾ The U-values apply to fitted doors with a door surface of 10 m² without glazing.

²⁾ Doors with ventilation slots, on request classes 2-3

³⁾ Up to 70 Pa water pressure

ThermoFrame // NEW

Improved thermal insulation for sectional doors

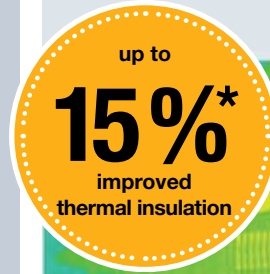

A well insulated garage door is always recommended when the garage and the home are directly connected. The ThermoFrame frame connection further improves the already high insulation values of the double-skinned Hörmann sectional garage doors, contributing to saving energy costs.

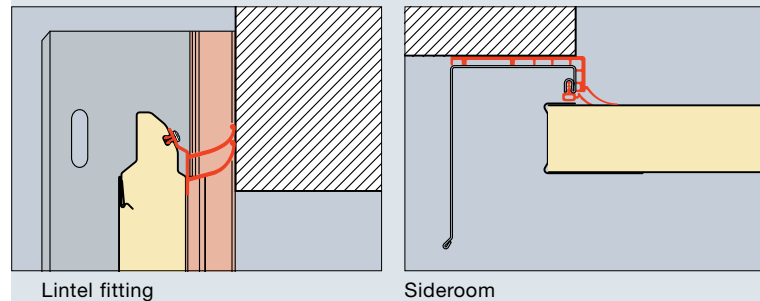

The plastic profile that can be simply fitted together with the door frame, creates an effective thermal break between the frame and the brickwork, improving the thermal insulation by up to 15%*.

In addition, extra lip seals on both sides and in the upper section of the door provide better sealing while lowering the loss of heating energy from the garage interior.

The optional ThermoFrame frame connection is optionally available for all Hörmann sectional garage doors.

* For an LPU sectional garage door with a door surface of 10 m².

Sectional Garage Doors

Dimensions and fitting data

Size range, LPU 40 XXL doors (intermediate widths and heights on request)

Door height Grid ordering size (RM)		
2250	Standard	Standard
2125	Standard	Standard
2000	Standard	Standard
	6000	6500
	Door width Ordering size (LZ)	
Inside garage dimension width (min.)	6250	6750

Door height Grid ordering size (RM)	N tracks		L tracks	
	(Min.) ceiling height	Clear passage height	(Min.) ceiling height	Clear passage height
Automatic garage doors				
2250	2640	2200	2510	2150
2125	2515	2075	2385	2025
2000	2390	1950	2260	1900
Manually operated doors				
2250	2640	2200	2550	2150
2125	2515	2075	2375	2025
2000	2390	1950	2200	1900

Track versions

Tension spring (Z)
tracks with tension spring technology
(not for LPU 40 XXL sectional doors)

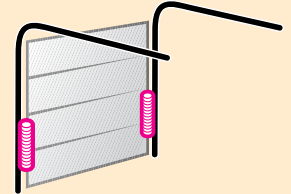

Normal (N)
tracks with torsion
spring technology

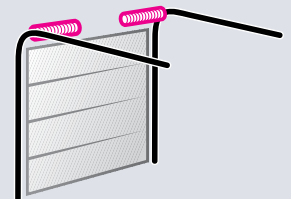

Low-headroom (L)
tracks with torsion spring technology

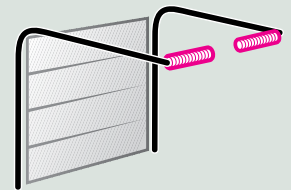

For more information on these
and further track versions consult
the technical manual or contact
your Hörmann specialist dealer.

Fitting with ThermoFrame

** When fitting with ThermoFrame and operator
Track application N + 45 mm
Door track application Z and L +30 mm

Sectional Garage Doors

Dimensions and fitting data

Track versions and fitting dimensions for all door types

Dimensions in mm

	Z tracks Doors with tension spring assembly	N tracks For doors with torsion spring assembly	L tracks For doors with torsion spring assembly
Automatic garage doors			
Overall length of operator with			
Door height up to 2125 (K-boom)	3200		3200
Door height up to 2250 (K-boom)		3200	
Door height up to 2375 (M-boom)	3450		3450
Door height up to 2500 (M-boom)		3450	
Door height up to 3000 (L-boom)	4125	4125	4125
Manually operated doors			
Required distance back	RM +510	RM +510	RM +750

Z, N and L tracks top view

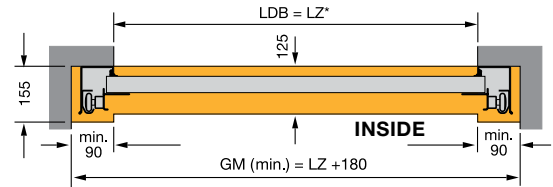

Z tracks

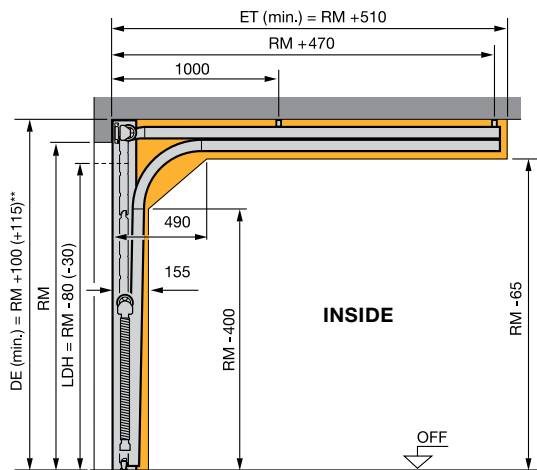

N tracks

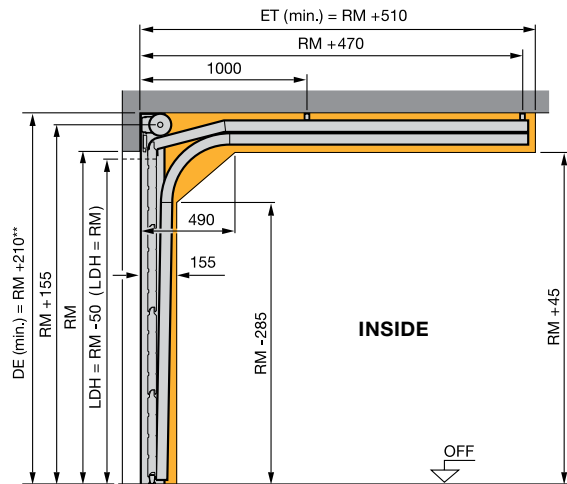

L tracks

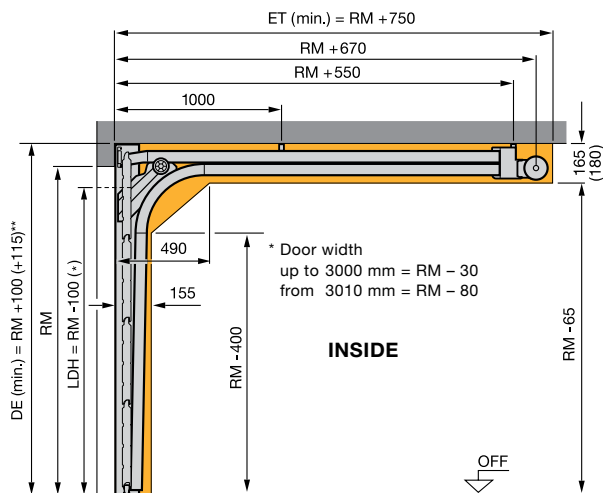

H tracks

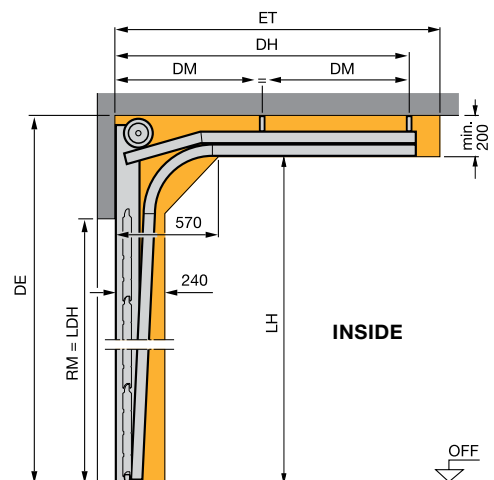

If you are interested in this track version for high-lift doors, contact your Hörmann specialist dealer.

For more information, consult the technical manual.

Dimensions in brackets are for doors with an operator.

Sectional Garage Doors

Dimensions and fitting data

Track versions and fitting dimensions for LPU 40 XXL doors			Dimensions in mm	
Automatic garage doors Overall length of operator with	N tracks For doors with torsion spring assembly	L tracks For doors with torsion spring assembly		
	Door height up to 2125 (K-boom)	3200		3450
	Door height up to 2125 (M-boom)	3450		4125
	Door height up to 2250 (M-boom)			
Door height up to 2250 (L-boom)				
Manually operated doors Required distance back	RM +440	RM +990		

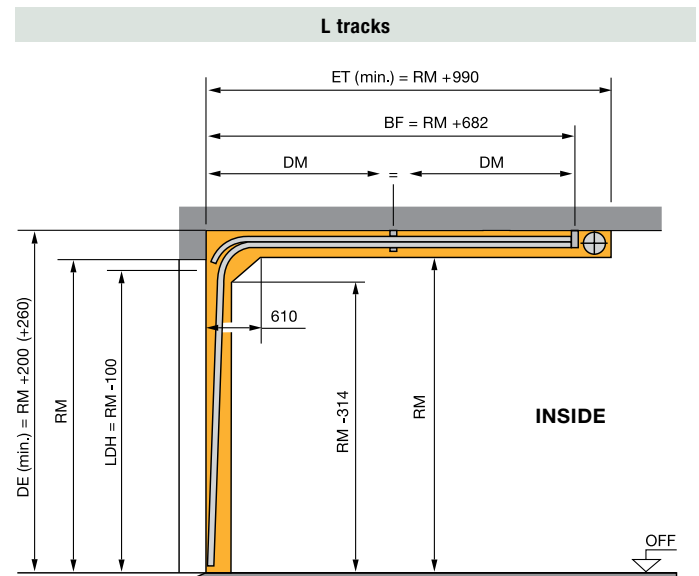
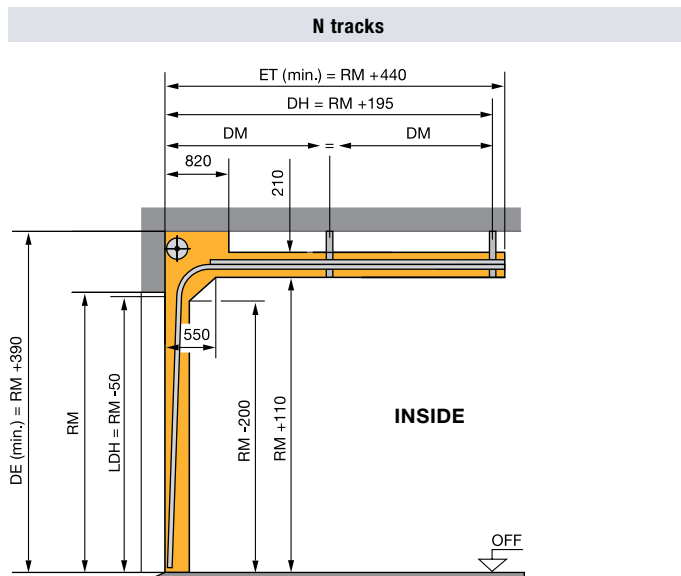

Explanation of dimensions

BF	Position of spring shaft
ET	Distance back
DE	Ceiling height
DH	Rear ceiling anchor
DM	Central ceiling anchor
GM	Inside garage dimension
LDB	Clear passage width
LDH	Clear passage height
LH	Track height
LZ	Clear frame dimensions (ordering size)
RM	Grid height (ordering size)

Please note

Before fitting a sectional door, the structural openings must be finished and the floors be laid and level. The clearance required for fitting the door must be free of supply lines, heater fans, etc.

Note: For more information, consult the technical manual.

Dimensions in brackets are for doors with an operator.

Fitting with ThermoFrame

* When fitting with ThermoFrame
 $LZ = LDB - 12 \text{ mm}$
 When fitting with ThermoFrame and frame covering
 $LDB = LZ - 15 \text{ mm}$

** When fitting with ThermoFrame and operator
 Track application N + 45 mm
 Door track application Z and L + 30 mm

Sectional Garage Doors LPU 40 with wicket door

Wicket door with trip-free threshold

Dimensions and fitting data

Size range doors with wicket doors

Dimensions in mm

Door height Grid ordering size (RM)	LPU 40, ribbed								LPU 40, panelled								Clear passage height of wicket door		
																	Ribbing	Panel and ribbing with glazing in the upper door section	
3000																	1955	1955	
2875	•	•	•	•	•	•	•	•	•	•	•	•	•	•	•	•	1871	1871	
2750																	2155	2155	
2625	•	•	•	•	•	•	•	•	•	•	•	•	•	•	•	•	2055	2055	
2500																	1955	1955	
2375																	1855	1855	
2250																	2123	2203	
2205									•	•	•	•	•	•	•		2075	2155	
2125																	1999	2079	
2080									•	•	•	•	•	•	•		1955	2035	
2000																	1875	1955	
1955									•	•	•	•	•	•	•		1827	1907	
1875																	1747	1827	
	2250	2375	2500	2750	3000	3250	3500	3750	4000	2250	2500	2750	3000	3250	3500	3750	4000		
	Door width (grid)								Door width (grid)										

Note: See the technical manual for possible glazing types and arrangements.

- Not possible for Decograin and Micrograin

N tracks

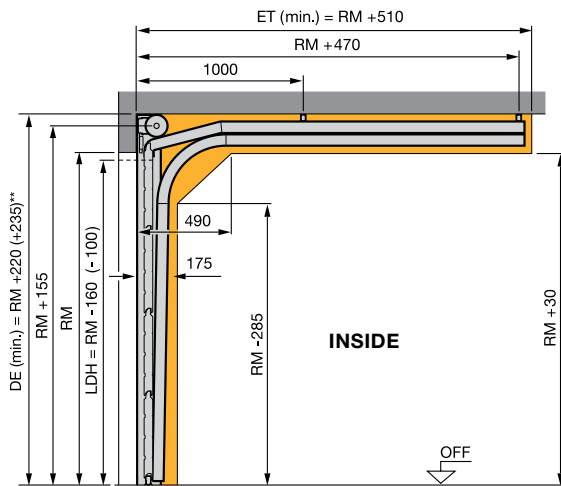

L tracks

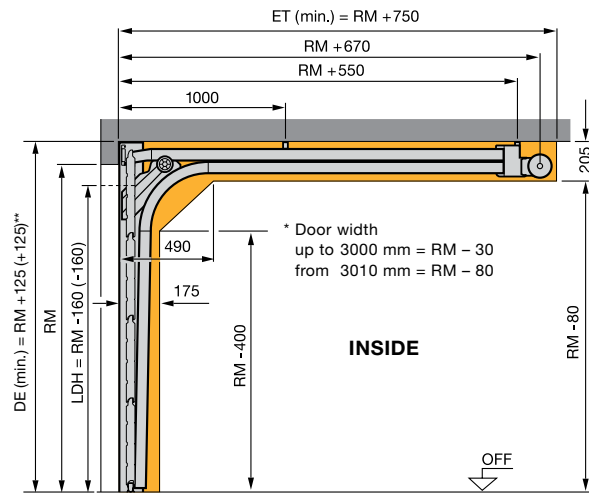

N and L tracks (top view)

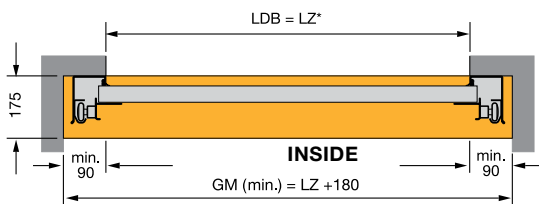

Please note

The opening height must not be less than the ordering size of the garage door (RM), otherwise the wicket door will not open.

Dimensions in brackets are for doors with an operator.

Fitting with ThermoFrame

- * When fitting with ThermoFrame
LZ = LDB - 12 mm
When fitting with ThermoFrame and frame covering
LDB = LZ - 15 mm
- ** When fitting with ThermoFrame and operator
Track application N + 20 mm
Track application L + 20 mm

Steel and Timber Side Doors

Sectional Garage Doors

Dimensions and fitting data

Standard sizes for steel side doors (special sizes on request) Dimensions in mm

Ordering size	Structural opening	Lever handle height from FFL		
		Profile type 1	Profile type 2	Profile type 3

Block frame, fitting behind the opening (ordering size = overall frame dimension)

Profile type 1 and 2, ribbed, panelled				
990 × 2058	855- 875 × 1990 -2000	955	1050	
990 × 2183	855- 875 × 2115 -2125	1010	1050	
1115 × 2058	980- 1000 × 1990 -2000	955	1050	
1115 × 2183	980- 1000 × 2115 -2125	1010	1050	

Block frame, fitting in the opening (ordering size = overall frame dimension)

Profile type 2, ribbed				
855 × 1990	875 × 2000		1050	
855 × 2115	875 × 2125		1050	
980 × 1990	1000 × 2000		1050	
980 × 2115	1000 × 2125		1050	

Corner frame, internal fitting (ordering size = nominal size)

Profile type 1, ribbed, panelled, profile type 2, ribbed				
875 × 2000		955	1050	
875 × 2125		1010	1050	
1000 × 2000		955	1050	
1000 × 2125		1010	1050	

Corner frame, external fitting (ordering size = nominal size)

Profile type 2, ribbed, profile type 3, ribbed, panelled				
875 × 2000			1050	955
875 × 2125			1050	1010
1000 × 2000			1050	955
1000 × 2125			1050	1010

Standard sizes for timber side doors (special sizes on request)

Fitting behind the opening (ordering size = overall frame dimension)

S-ribbed, V-panelled				
1005 × 2190	855- 875 × 2115 -2125		1050	
1130 × 2190	980- 1000 × 2115 -2125		1050	

With special designs				
1130 × 2190	980- 1000 × 2115 -2125		1050	

Steel side door with block frame, profile type 2, fitting behind the opening

Steel side door with block frame, profile type 2, fitting in the opening

Steel side door with aluminium corner frame, profile type 2, external fitting

Timber side door, fitting behind the opening

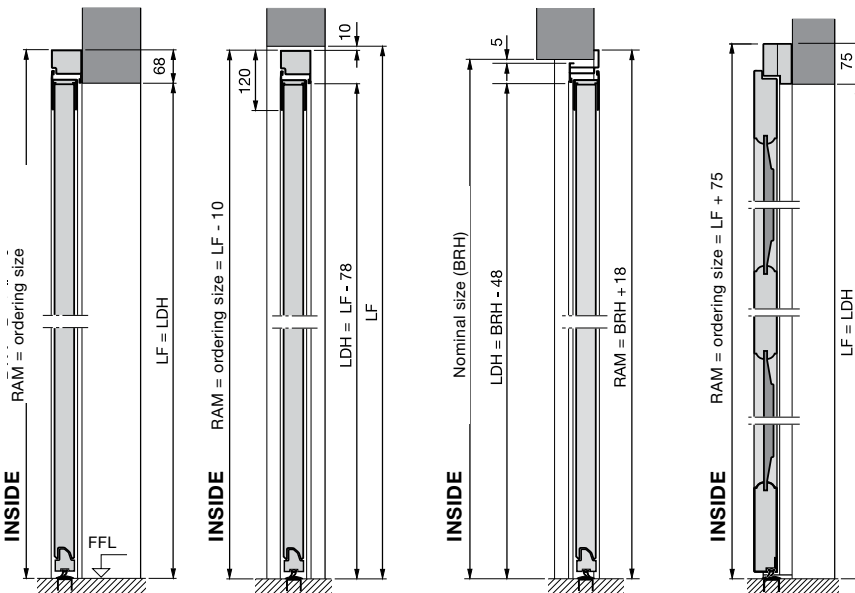

Dimensions in mm Top view

Steel side door with aluminium block frame, fitting behind the opening, example profile type 1

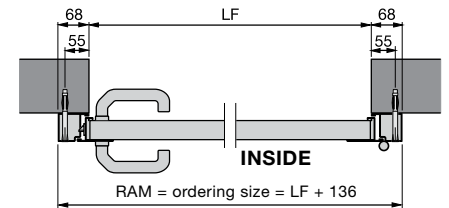

Steel side door with aluminium block frame, fitting in the opening, example profile type 2

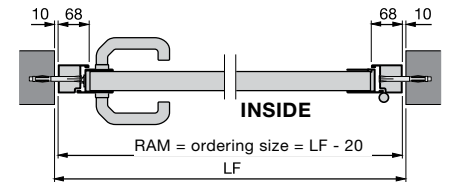

Steel side door with aluminium corner frame, external fitting, profile type 3

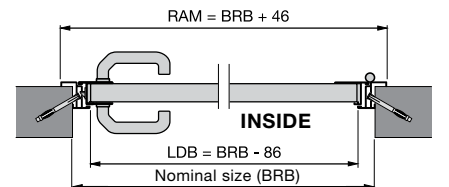

Timber side door Fitting behind the opening

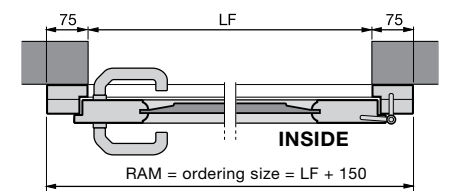

Note: For more information, consult the technical manual.



Hörmann: Quality without Compromise



Hörmann KG Amshausen, Germany



Hörmann KG Antriebstechnik, Germany



Hörmann KG Brandis, Germany



Hörmann KG Brockhagen, Germany



Hörmann KG Dissen, Germany



Hörmann KG Eckelhausen, Germany



Hörmann KG Freisen, Germany



Hörmann KG Ichtershausen, Germany



Hörmann KG Werne, Germany



Hörmann Genk NV, Belgium



Hörmann Alkmaar B.V., Netherlands



Hörmann Legnica Sp. z o.o., Poland



Hörmann Beijing, China



Hörmann Tianjin, China



Hörmann LLC, Montgomery IL, USA



Hörmann Flexon, Leetsdale PA, USA

Hörmann is the only manufacturer worldwide that offers you a complete range of all major building products from one source. We manufacture in highly-specialised factories using the latest production technologies. The close-meshed network of sales and service companies throughout Europe, and activities in the USA and China, make Hörmann your strong partner for first-class building products, offering “Quality without Compromise”.

GARAGE DOORS

OPERATORS

INDUSTRIAL DOORS

LOADING EQUIPMENT

HINGED DOORS

DOOR FRAMES



Experience real Hörmann quality

Entrance doors

Comprehensive entrance door ranges to fit almost every need and requirement.



Canopies

The practical complement to your preferred entrance door.

Steel doors

Fitting in a flash: sturdy doors for your entire home, from the basement to the roof.



Frames

Choose from our comprehensive range of products for new construction, expansion, and modernisation.

Garage doors

Match your personal architectural style: up-and-over or sectional doors made of steel, timber or grp.



Door operators

Enjoy the convenience: Hörmann operators for garage doors and entrance gates.