

6229 Industrial Footswitch

herga

Technology Ltd

For IPX7 single pole switching

- Low profile, rear hinged switch designed for improved user comfort
- All plastic construction with raised tread pattern and anti-slip pad
- Versatile and innovative design make it an ideal product for OEM use
- Switches designed to meet industrial/office/commercial standards
- Increased temperature range of -20 to +80°C

Outline dimensions

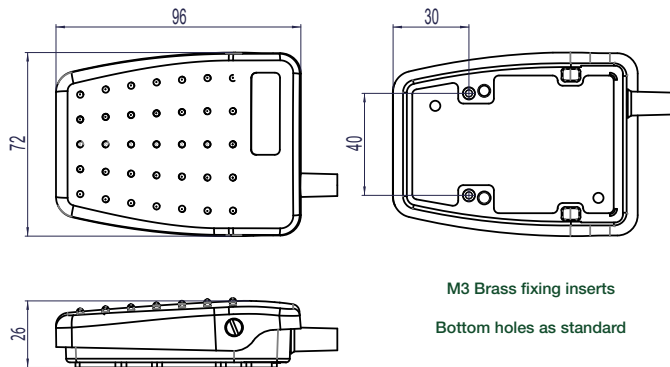

General specifications

Standards/approvals	Footswitch: EN 60950	Operating temperature range	-20°C to +80°C
Degree of protection	EN 60529 IPX7	Body material	Thermoplastic
Connection method	2 m of cable with stripped cable cores	Weight	0.14Kg (including cable)
Electrical rating	Max. 3A 250V AC/DC	Additional information	Customized versions available (logos, cordsets, colours, guards)
Contact configuration	SPCO		

6229: Ordering and options

6229 - [] C B [] - Z B ZZ

