

magO : URBAN

Manufacturas Mago, SL

Pol. Industrial Masia d'en Barreres, s/n
Ap. Postal 25
08800 Vilanova i la Geltrú
Barcelona [España]

Tel | España | 902 111 893
| N° vert – Appel gratuit depuis la France | 0800 888 263
| Internacional | +34 93 814 86 61

Fax | España | 93 893 32 50
| Internacional | +34 93 893 32 50

magO : URBAN

e-mail | info@magogroup.com
www.magogroup.com

D.L.B-34566-2007

Archivos DXF / DWG disponibles en www.magogroup.com [mobiliario urbano] | Arxius DXF / DWG disponibles a www.magogroup.com [mobiliari urbà]

Documents DXF / DWG available on www.magogroup.com [urban items] | Documents DXF / DWG disponibles sur www.magogroup.com [mobilier urbain]

<p>Manufacturas Mago, SL Pol. Industrial Masia d'en Barreres, s/n Ap. Postal 25 08800 Vilanova i la Geltrú Barcelona [España]</p>	<p>Tel España 902 111 893 N° vert – Appel gratuit depuis la France 0800 888 263 Internacional +34 93 814 86 61</p> <p>Fax España 93 893 32 50 Internacional +34 93 893 32 50</p>	<p>mago URBAN</p> <p>e-mail info@magogroup.com www.magogroup.com</p>
--	---	--

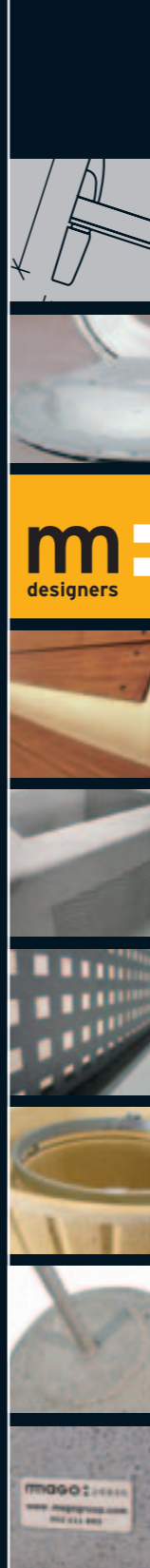

DXF | DWG

disponibles en www.magogroup.com [mobiliario urbano]
 disponibles a www.magogroup.com [mobiliari urbà]
 available on www.magogroup.com [urban items]
 disponibles sur www.magogroup.com [mobilier urbain]

04

ELEMENTOS PREFABRICADOS A MEDIDA
 ELEMENTS PREFABRICATS A MIDA
 PREFABRICATED CUSTOM-MADE ELEMENTS
 ELEMENTS PRÉFABRIQUÉS SUR MESURE

06

m designers

DISEÑADORES
 DISSENYADORS
 DESIGNERS
 DESIGNERS

12

bancos
 bancs
 benches
 bancs

46

jardíneras
 jardineres
 plant pots
 jardinières

60

límites arquitectónicos
 límits arquitectònics
 architectonic limits
 limites architectoniques

70

miscelánea
 miscel·lània
 miscellaneous
 divers

88

ELEMENTOS Y TRATAMIENTOS OPCIONALES
 ELEMENTS I TRACTAMENTS OPCIONALS
 OPTIONAL ITEMS AND TREATMENTS
 ÉLÉMENTS ET TRAITEMENTS OPTIONNELS

90

CARACTERÍSTICAS TÉCNICAS | CONDICIONES GENERALES DE VENTA
 CARACTERÍSTIQUES TÉCNIQUES | CONDICIONS GENERALS DE VENDA
 TECHNICAL FEATURES | GENERAL SALES TERMS
 CARACTERISTIQUES TECHNIQUES | CONDITIONS GÉNÉRALES DE VENTE

Petra

mago URBAN

FABRICAMOS SUS DISEÑOS

mago: pone a su disposición todo el conocimiento, experiencia e infraestructura industrial para fabricar cualquier elemento de mobiliario urbano o arquitectónico.

A partir de su diseño, elaboramos un prototipo, realizamos el molde y producimos el número de unidades que deseen.

mago: sus proyectos hechos realidad.

FABRIQUEM ELS VOSTRES DISSENYYS

mago: posa a la vostra disposició tot el coneixement, experiència i infraestructura industrial per fabricar qualsevol element de mobiliari urbà o arquitectònic.

Un cop aportat el vostre disseny, elaborem un prototip, realitzem un motlle i produïm el nombre d'unitats que desitgeu.

mago: els vostres projectes fets realitat.

MANUFACTURING YOUR DESIGNS

mago: places all its knowledge, experience and infrastructures at your disposal for manufacturing any element for urban or architectural furniture.

We will make a prototype from your design and we can then make the mould and produce as many units as you wish.

mago: your projects become a reality.

NOUS FABRIQUONS VOS DESIGNS

mago: met à votre disposition toute la connaissance, l'expérience et l'infrastructure industrielle pour fabriquer n'importe quel élément de mobilier urbain ou architectonique.

A partir de votre dessin, nous élaborons un prototype, nous réalisons le moule et nous produisons le nombre d'unités que vous désirez.

mago: Vos projets prennent corps.

FABRICAMOS SUS DISEÑOS

FABRIQUEM ELS VOSTRES DISSENYYS

MANUFACTURING YOUR DESIGNS

NOUS FABRIQUONS VOS DESIGNS

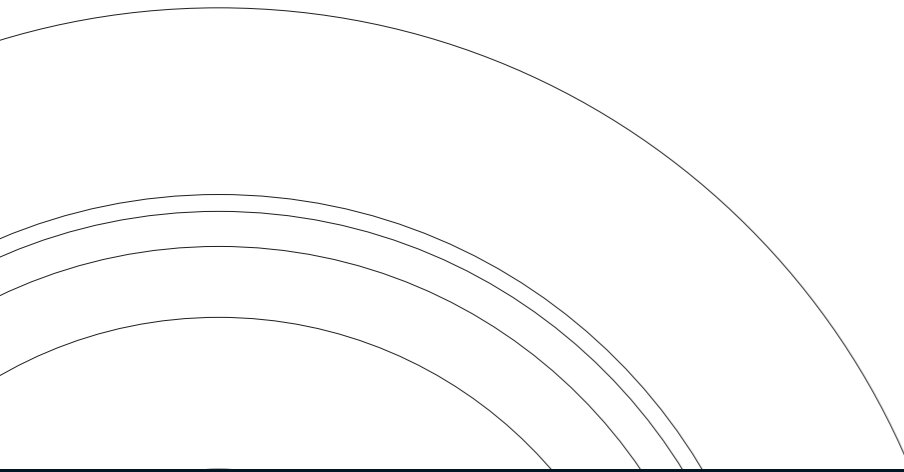

mago: URBAN

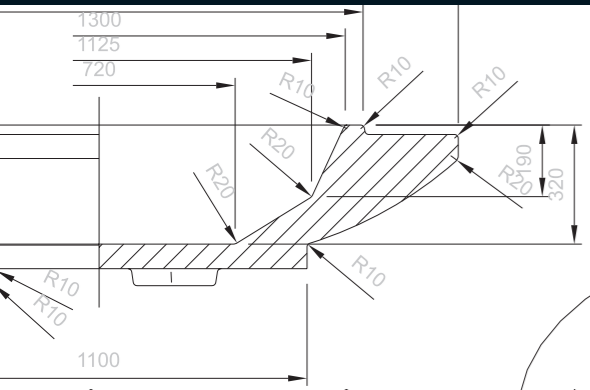

Javier + José Luis

díez + díez diseño

Study established by Mr. Javier Díez, industrial designer and José Luis Díez, interior designer.

They have collaborated with several companies from the urban elements sector.

Prizes:

- Delta de Plata given by ADI-FAD in 2005 for the bench Godot. They have been selected by ADI-FAD several times with other elements.

- Prize given by the Organisation of designers of Spain, AEPD, for the Godot.

Different elements have been shown in some exhibitions and magazines.

www.diezmasdiez.com

Mago design > zen



Erera

Ernest Perera

(Vilanova i la Geltrú 1974)

In 1998 he established the design studio Dforma.

Professor at the Eina School of Art & Design and ESDI, higher School of Design.

He has collaborated with different companies as: Camper, S.C.P.F, Gesimpex, Generalitat de Catalunya, Xarxa de Biblioteques de Barcelona, Cerabella, Ayats,...

He has exhibited his work in Milan, Paris, New York, Seul, Brussels, Barcelona,...

www.ernestperera.com
contact@ernestperera.com

Mago designs > H bn, H cn, TV, via làctea, quad, cilo, icon



Moussavi

FOA

FOREIGN OFFICE ARCHITECTS (F.O.A.)
Farshid Moussavi & Alejandro Zaera Polo

Farshid Moussavi

Professor at the Akademy of Fine Arts, Vienna, Austria. MArch II, Graduate School of Design, Harvard University, USA.

Dipl. Architecture, Bartlett School of Architecture, UK.

Alejandro Zaera Polo

Dean of the Berlage Institute, Rotterdam, The Netherlands MArch II, Graduate School of Design, Harvard University, USA.

Dipl. Architecture (Hons), E.T.S. of Architecture in Madrid, Spain.

Projects:

- > 2003-07 BBC Music Box.
- > 2003-2006 Centro Tecnológico de la Rioja y Parque de la Fombera, Logroño.
- > 2000-04 Litoral Auditorium Park - Barcelona.
- > 1995-02 Yokohama International Ferry Terminal, Yokohama, Japan.
- > 2002- Barcelona Zona Franca Office Park.
- > 2000-04 La Villa Joyosa, Spain.

mail@f-o-a.net
www.f-o-a.net

Mago design > cuc



Guido Marsille

Architectural Design, specialisation Public Domain, AKI, Enschede, The Netherlands.

2004 buroMARSILLE, office for public space design, Rotterdam, The Netherlands.

2002-2003 Schie2.0 in collaboration with Jan Konings, Claus Wiersma, Rotterdam, The Netherlands.

1995-2000 West 8 Landscape Architects, designer & projectmanager, Rotterdam, The Netherlands.

Projects:

- > 'PAUZE-BENCHE', streetbenches, Amsterdam, The Netherlands, 2004.
- > 'KRAT', public space crate furniture, 2004.
- > 'DISH', planter, Urban Elements, Soest, The Netherlands, 2004, buroMARSILLE / Schie2.0
- > "RUN DRY", chatbox for public space, The Hague, The Netherlands, 2002, Schie2.0.
- > 'SCHOOLBENCHES', Drachten, The Netherlands, 2002, Schie2.0.
- > 'LAMP', exterior lighting, Lensvelt BV, 2001, buroMARSILLE.

e guido@marsille.com

Mago design > dish



Cinca

Joan Cinca

(Barcelona 1974)

Designer – Escoles Superiors d'Arquitectura i Enginyeria from UPC.

Industrial Technical Engineer – EUPM from UPC.

He has collaborated with engineering + desing SA in projects for Porsche, Renault, Opel, BMW, Volkswagen group.

He collaborates with Tactica study designing products for Simon, Renault, SunRed, Cata...

He is teacher in Elisava School and Art's and design school of Terrassa.

Awards:

- 1st prize in ADI FAD awards in the new applications category 2005.
- 2nd prize of lamps organised by Associació Cultural Levide.



Jordi Miralles Tintoré

Bsc. Architecture by ETSAB of UPC.

Manager of Urbanism department in the town council of Vilanova i la Geltrú.

Several urbanism projects chosen by the 3rd European biennial of Landscape of Barcelona.

1st prize of Towns of Quality in 2006, organised by Diputació de Barcelona, for the repairs and adaptation of the old district of Vilanova, La Geltrú.

Mago designs > balisa JM, +vorera, pass, portic

Miralles

Jordi Miró Surroca

Industrial Technical Engineer by the UPC, Vilanova i la Geltrú.

Town Council Technical Engineer in Vilanova i la Geltrú.

Mago designs > balisa JM, +vorera

Miró



Juan Carlos Bolaños

Architect of Universidad Nacional de Colombia (1989).
Architect specialized in housing and landscapes design.
Designer and Project Manager of Urban Spaces in Instituto de Desarrollo Urbano de la Ciudad de Bogota. (1999-2001).

Since 2001 he becomes member of Arconcret in Barcelona, company dedicated to design and coordinate Urban Concrete Elements as well as pre-cast items for construction and housing.

Public Spaces Projects:

- › 11 Urban Squares in Bogotá (140.000 m²).
- › Boulevards and Urban Platforms (255.000 m²).
- › Bike Routes (270 Km).
- › Urban Pavement Manual of Bogota (collaborator).
- › Terrazzo Manual (Barcelona) with the engineer Mr. Xavier Regàs.

Urban Furniture:

- › Design of Q+bo (modular system of urban furniture)

arconcret@wtcbarcelona.es
www.arconcret.com

Mago design › cap i cua

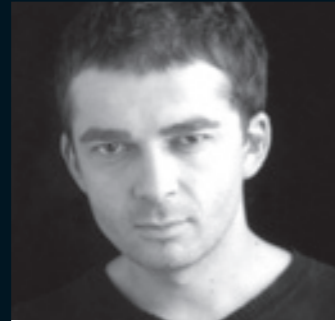

Oriol Guimerà

Industrial Designer - Elisava School (1994).
Enterprise Creation & Management by Pompeu Fabra University IDEC and EUNCET in Terrassa.

He has collaborated with Isao Hosoe Design Study (Milan).

He has designed products for companies as Santa&Cole, Simón S.A., Bacardi España.

oriolguimera@tactica42.com
www.tactica42.com

Mago designs › pausa, siedi b, siedi c, pausita



Roger Albero

(Barcelona 1971)

Industrial Designer - Elisava School.

1999-2002 He collaborated with Oscar Tusquets Design Study.

He has designed urban items for different companies. We can mention some of them: Dae, Colomer, Grupo-T, Ahrend/Ibercaja, Leader y Blauet.

roger@rogeralbero.com
www.rogeralbero.com

Mago designs › tetris, crusöe, tube, fractal



Teruel i Paré

Josep J. Teruel i Samsó (Barcelona 1952) is an Architect by ETSAB (The Barcelona Technical College of Architecture), Industrial Designer by Escola Elisava and completed his studies in Landscaping at ETSAB. Since 1996 he is a lecturer at the Department of Design and Image, Faculty of Fine Arts, University of Barcelona, and since 2003 at the Instituto Europeo di Design in Barcelona.

Ignasi Paré i Busto (Barcelona 1967) is an Industrial Design by the Escola Elisava and took a Master's Degree in Industrial Designer and Product Development at the UPC.

He has collaborated with the research centre of Instituto Europeo di Design in Milan. Since 2002 he is a teacher at the Instituto Europeo di Design in Barcelona.

The studio collaborate with different companies like: As Dara Mobiliari, Meta International, Tapizados Gems, Levesta, Blauet, Industrias Aja ...

www.teruelpare.com
info@teruelpare.com

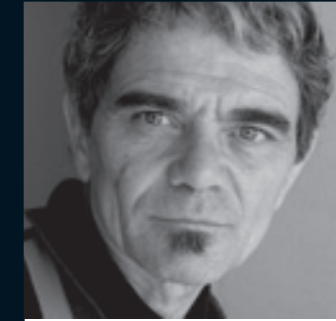

Ton Riera Ubía

Since 1975 he has been involved with Industrial, Graphic, Interior and Urban Designs Projects.

He carries out different Urban and Domestic Projects for a large number of companies.

Awards:

- › Nube Chair - "Mueble de Valencia" Fair 1987.
- › Meteora Chair - G-Mark Japan Industrial Ministry
- › Tronic Set - "Delta de Oro" ADI-FAD 1992..

Mago designs › killy, bloop, bloop wood, recte, sinus, corinto, tanit, fuat fuat quadrat, rodas, limitot, sunion, paros, circular, kimba, fit-A, zaphir, sassi



Xavier Bruçet

(Mataró 1970)

Interior Designer: Pau Gargallo

It emphasizes the performance of public used spaces, in the service sector, and the interior renovation of private homes.

Industrial Designer: "La Llotja" School.

He has collaborated, among other companies, with: Estiluz, Telemat, Piresa Aqua, Tapicerias Gems, Roig-Tronic, Artesania Cervera, Pack-plek, Gres de Breda....

ondia@tiscali.es

Mago designs › ursus, damero

bancos | bancs | benches | bancs

cuc	p.	14
zen	p.	16
zen duo	p.	17
zen trio	p.	17
sassi	p.	18
sassi R	p.	18
pausa	p.	19
crusõe	p.	20-21
coma	p.	22-23
kimba cóncavo	p.	24-25
kimba convexo	p.	24-25
kimba R 1,42	p.	24-25
kimba R 2,12	p.	24-25
kimba T ext	p.	24-25
kimba T int	p.	24-25
kioto B	p.	26-27
kioto B+R	p.	26-27
kioto R	p.	26-27
tube banca	p.	28-29
tube cubo	p.	28-29
tube silla	p.	28-29
tube tumbona	p.	28-29
tetris Q	p.	30-31
tetris I 150	p.	30-31
tetris I 220	p.	30-31
tetris J	p.	30-31
tetris X	p.	30-31
tetris L	p.	30-31
tetris O	p.	30-31
tetris T	p.	30-31
tetris C	p.	30-31
tetris C 30°	p.	30-31
bloop 2 m	p.	32
bloop 3 m	p.	32
bloop path	p.	33
bloop rest L	p.	34
bloop rest C	p.	34

bancos | bancs | benches | bancs

recte	p.	35
ursus	p.	36
damero	p.	37
H cn	p.	38
H bn	p.	38
quad b	p.	39
killy 3	p.	40
killy 3 F - killy 3 I	p.	40
killy 1	p.	41
killy 1 F - killy 1 I	p.	41
killy 4	p.	42-43
killy 4 F - killy 4 I	p.	42-43
killy 2	p.	42-43
killy 2 F - killy 2 I	p.	42-43
sinus	p.	44
corinto	p.	44
siedi b	p.	45
siedi c	p.	45

jardineras | jardineres | plant pots | jardinières

dish	p.	48-49
tanit L	p.	50-51
tanit M	p.	50-51
tanit SM	p.	50-51
tanit S	p.	50-51
fuat Q60	p.	52-53
fuat Q80	p.	52-53
fuat Q60 p	p.	52-53
fuat Q80 p	p.	52-53
fuat R60	p.	52-53
fuat R80	p.	52-53
fuat S85	p.	52-53
fuat R60 p	p.	52-53

jardineras | jardineres | plant pots | jardinières

fuat R80 p	p.	52-53
fuat S85 p	p.	52-53
quadrat	p.	54
quadrat p	p.	54
circular	p.	55
tetris J	p.	56
fractal	p.	57
zaphir	p.	58
flandes/reforestation		
pinewood/pin des		
flandes	p.	59

límites | límits | limits | limites

cilo	p.	62
quad	p.	63
ursus I 60	p.	64
ursus I 70	p.	64
ursus I 100	p.	64
pausita	p.	65
rodas	p.	66
rodas rf	p.	66
tube límite	p.	67
fit A	p.	68
limitot	p.	69



miscelánea | miscel.lània | miscellaneous | divers

balisa JM	p.	72-73
via làctea 120	p.	74
via làctea 160	p.	74

miscelánea | miscel.lània | miscellaneous | divers

TV 120	p.	75
TV 160	p.	75
cap i cua	p.	76
portic	p.	77
sunion	p.	78
paros	p.	79
quad bike	p.	80
quad p	p.	81
quad pt	p.	81
versatil	p.	82
icon	p.	83
pass	p.	84-85
+vorera	p.	86-87

Archivos DXF / DWG disponibles en www.magogroup.com [mobiliario urbano]
 Arxius DXF / DWG disponibles a www.magogroup.com [mobiliari urbà]
 Documents DXF / DWG available on www.magogroup.com [urban items]
 Documents DXF / DWG disponibles sur www.magogroup.com [mobilier urbain]

cuc pag. 14		zen pag. 16		zen duo pag. 17		zen trio pag. 17		sassi pag. 18		sassi R pag. 18	
pausa pag. 19		crusõe pag. 20		coma pag. 22		kimba R 1,42 pag. 24		kimba 2,12 pag. 24		kimba T int pag. 24	
kimba T ext pag. 24		kimba cóncavo pag. 25		kimba convexo pag. 25		kioto B pag. 26		kioto R pag. 27		kioto B+R pag. 27	
tube silla pag. 28		tube banca pag. 28		tube cubo pag. 29		tube tumbona pag. 29		tetris Q pag. 30		tetris I 150 pag. 30	
tetris I 220 pag. 30		tetris J pag. 30		tetris X pag. 30		tetris L pag. 31		rtetris O pag. 31		tetris T pag. 31	
tetris C pag. 31		tetris C 30º pag. 31		bloop 2 m pag. 32		bloop 3 m pag. 32		bloop path pag. 33		bloop rest L pag. 34	
bloop rest C pag. 34		recte pag. 35		ursus pag. 36		damero pag. 37		H cn pag. 38		H bn pag. 38	
quad b pag. 39		killy 3 pag. 40		killy 3 F pag. 40		killy 3 I pag. 40		killy 1 pag. 41		killy 1 F pag. 41	
killy 1 I pag. 41		killy 4 pag. 42		killy 2 I pag. 42		killy 2 F pag. 42		killy 4 I pag. 43		killy 4 F pag. 43	
killy 2 pag. 43		corinto pag. 44		sinus pag. 44		sidi b pag. 45		siedi c pag. 45			



Parc dels Auditoris de Barcelona
 Forum de les Cultures Barcelona 2004, Spain.
 Design by Foreign Office Architects (FOA)
 Farshid Moussavi & Alejandro Zaera Polo.

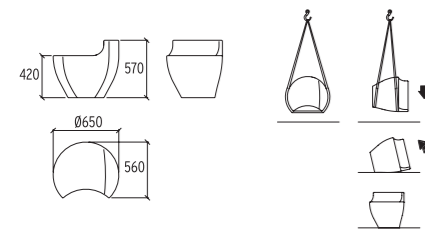

Selecció
 ADI-FAD 2005



CUC
 design > Foreign Office Architects (FOA)
 Farshid Moussavi & Alejandro Zaera Polo
 special thanks > Kenichi Matsuzawa
 229 kg

Maqo Divisi3n Urbana is very grateful to Pablo Ros for this collaboration

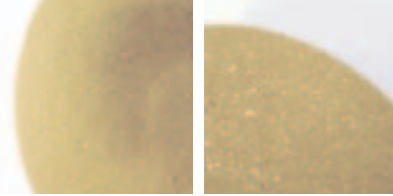

zen | design > díez + díez diseño



zen | 229 kg |

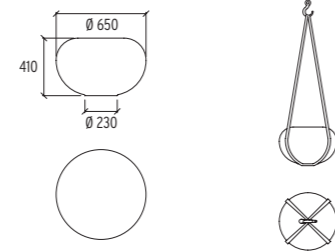

Centro Comercial Dos Mares. San Javier. Murcia, Spain. Design by Ingeniería Díez Cisneros S.A.



zen duo | 510 kg |

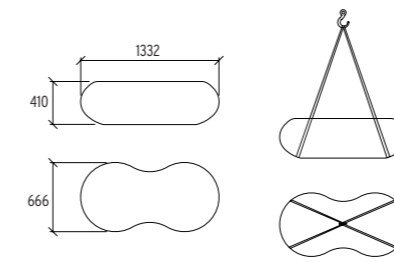

zen trío | 815 kg |

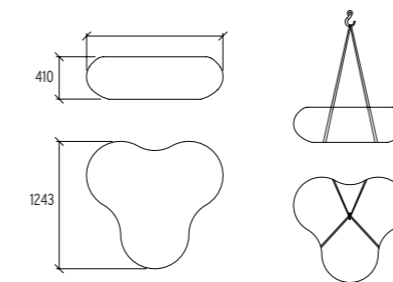

bancos | bancs | benches | bancs

bancos | bancs | benches | bancs

sassi | design > Ton Riera | 1.300 kg |

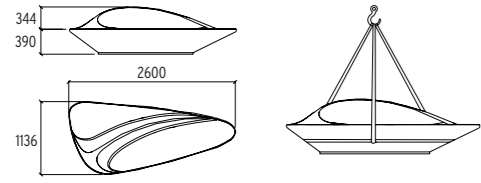

sassi R | design > Ton Riera | 1.600 kg |

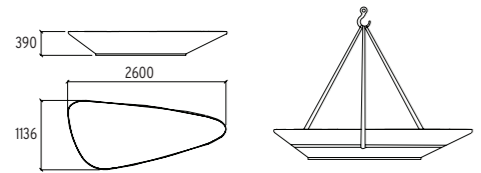

Sel·lecció
ADI-FAD 2001

pausa | design > Oriol Guimerà | 940 kg |

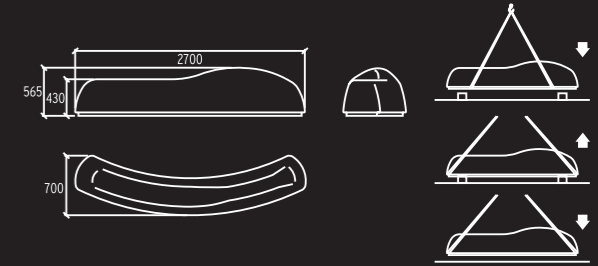

complementary elements

pausa pag. 65



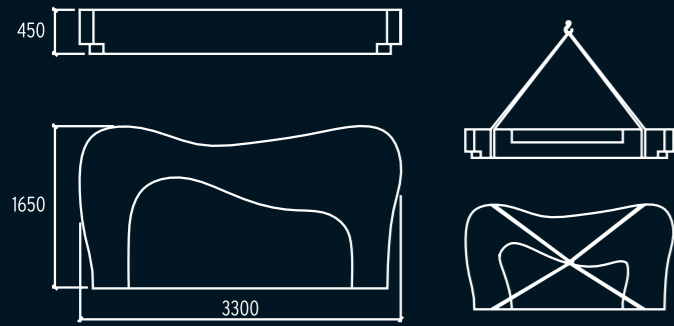

crusöe A | 3.570 kg |

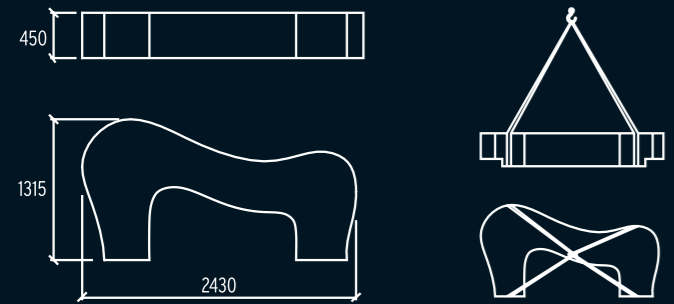

crusöe B | 1.815 kg |

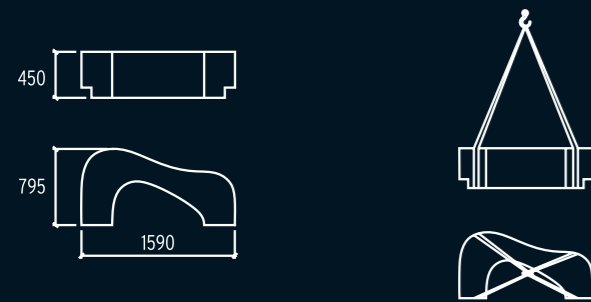

crusöe C | 685 kg |



AEPD asociación española de profesionales del diseño

Selection AEPD 2006

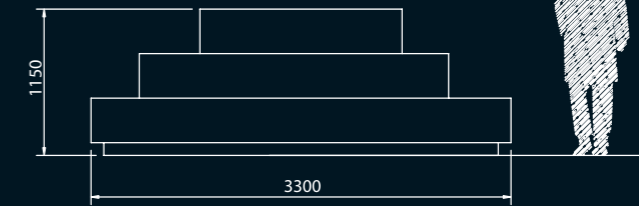

crusöe | design > Roger Albero | 12.140 kg |

recomendamos plantar / recomanen plantar
we recommend to plant / Nous vous proposons planter

palmeras | palmeres | palms | palmiers: Chamaerops humilis, Washingtonia, Cyca

árboles | arbres | trees | arbres: Acer japonicum, Albizia, Arbutus unedo, Catalpa bungei, Lagerstroemia, Ligustrum japonicum, Magnolias, Morus, Prunus, Rhus typhina, Robinia pseudoacacia unbraculifera, Olivo, Citricos...

arbustos | arbustos | shrub | arbustes: Bambúes | bambús | bamboo | bambou

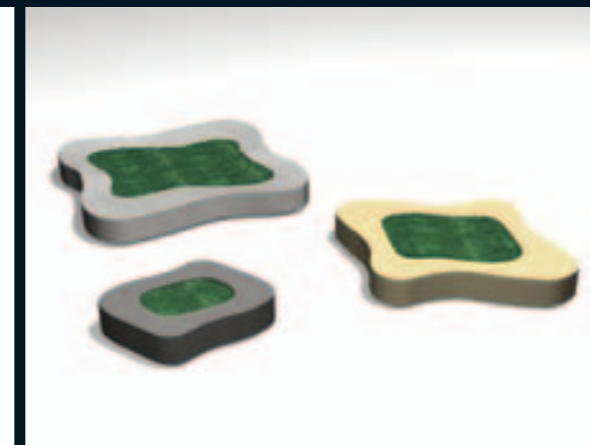
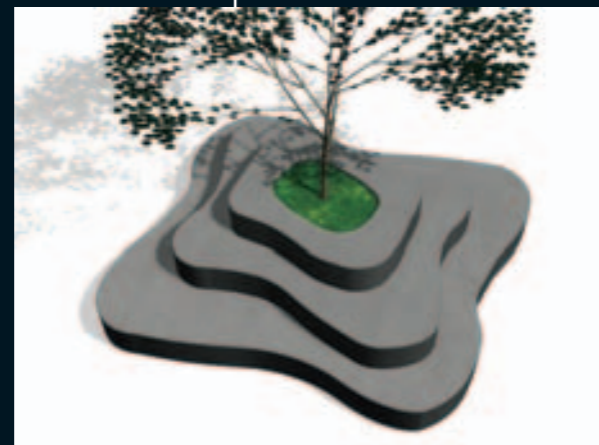

bancos | bancs | benches | bancs

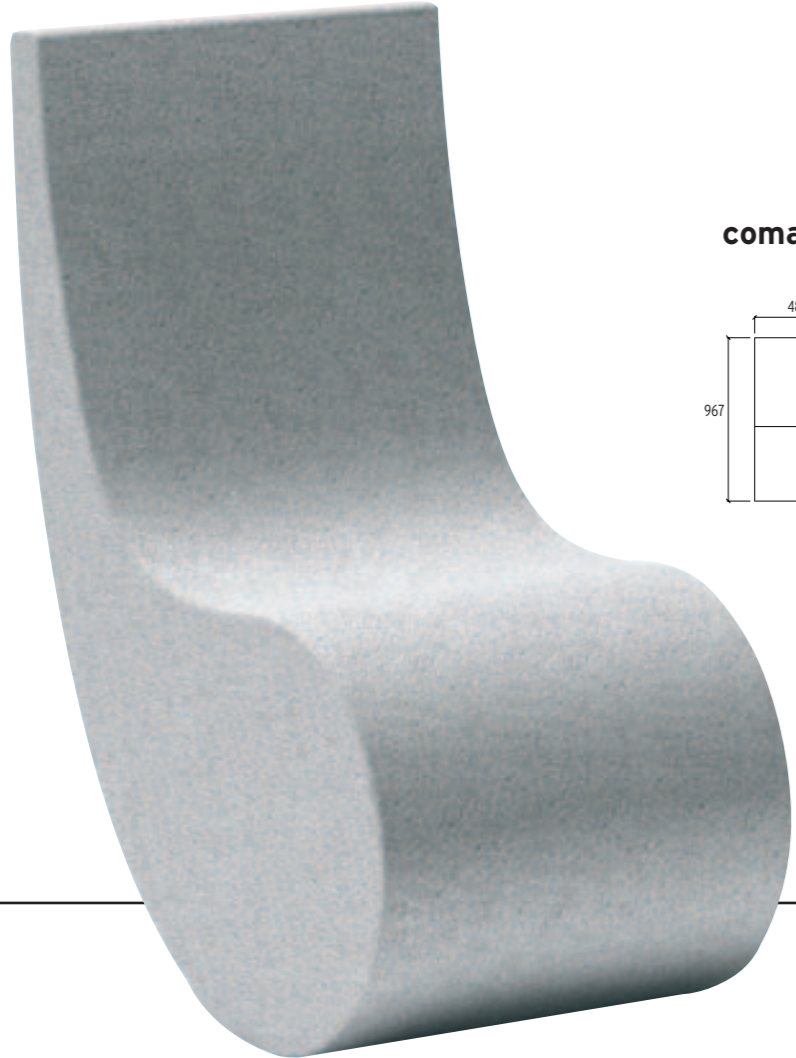

coma | design > Joan Cinca | 250 kg |

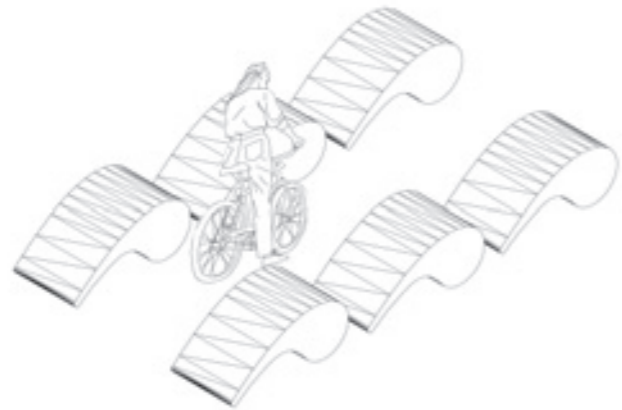
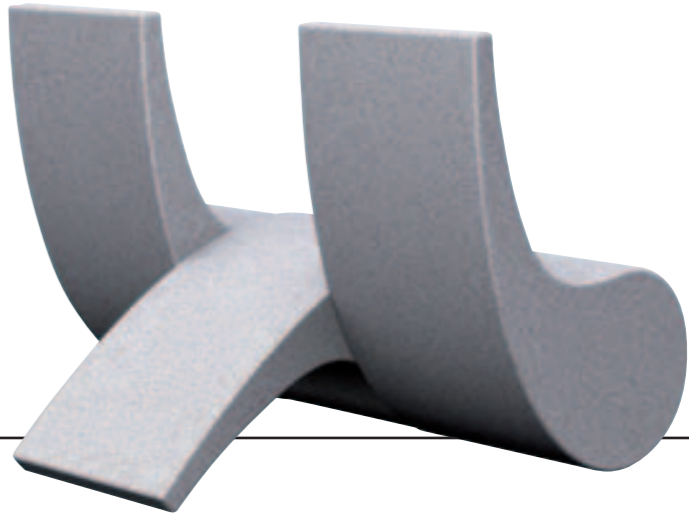
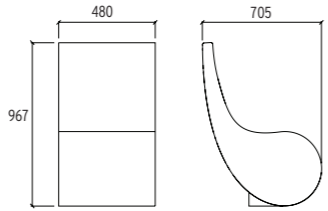



kimba | design > Ton Riera

kimba R 2,12 | 977 kg |

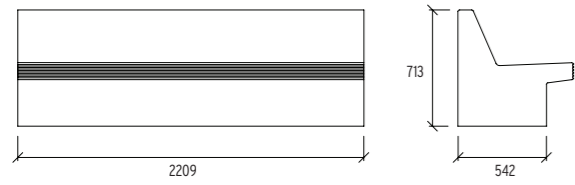

kimba cóncavo | 1.012 kg |

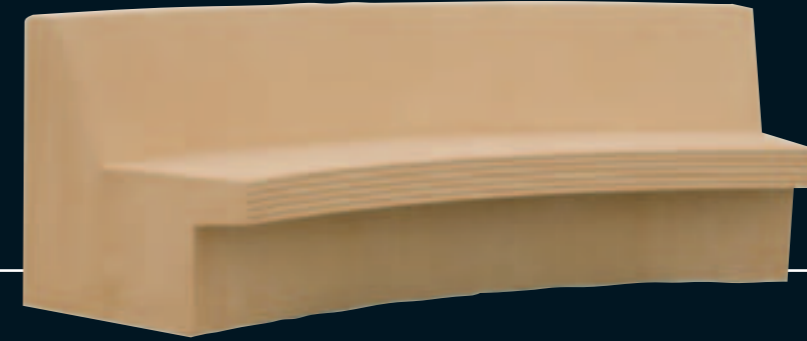
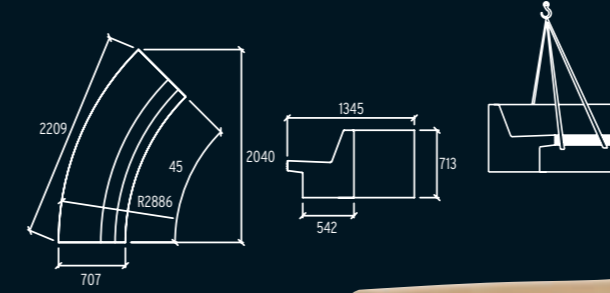

kimba R 1,42 | 617 kg |

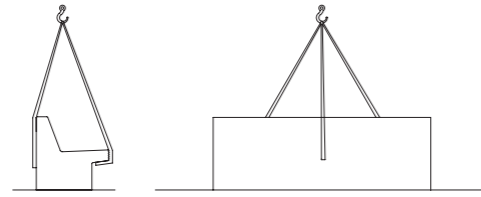
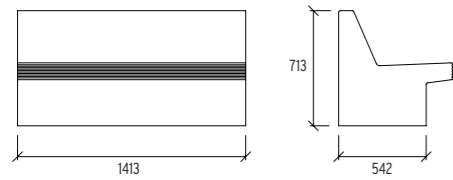

bancos | bancs | benches | bancs

bancos | bancs | benches | bancs

kimba T ext | 425 kg |

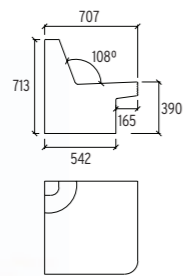

kimba T int | 835 kg |

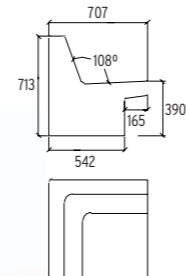

kimba convexo | 952 kg |

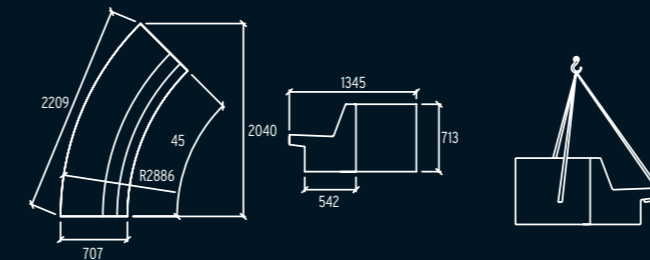



kioto | design > Teruel / Paré

kioto R | 770 kg |

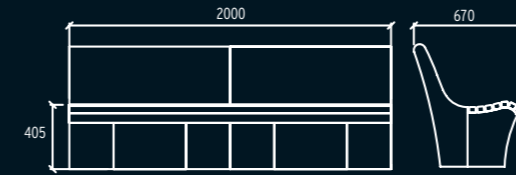

kioto B | 340 kg |

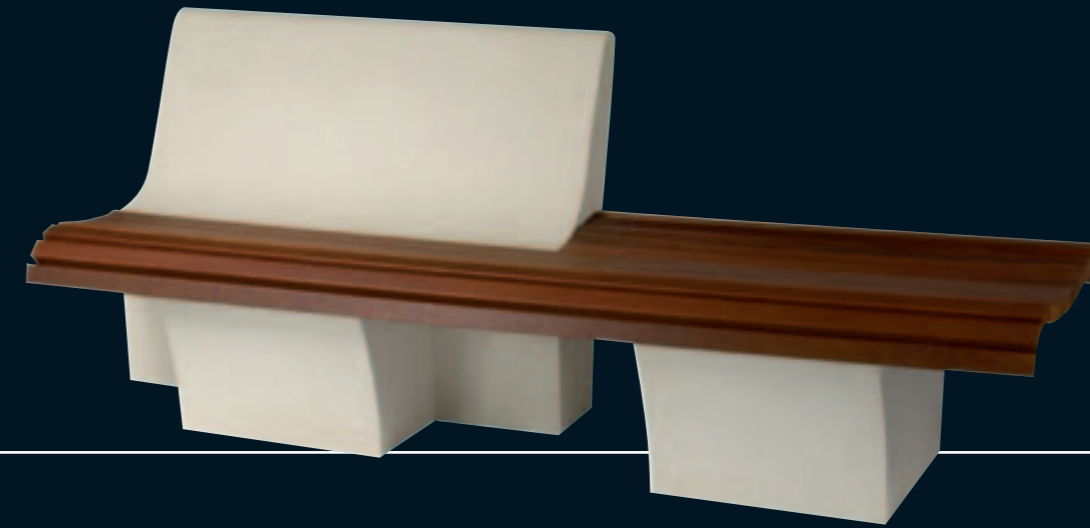
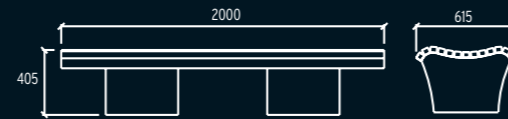

kioto B+R | 555 kg |

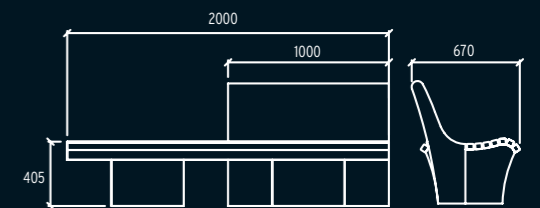



tube | design > Roger Albero

tube silla | 310 kg |

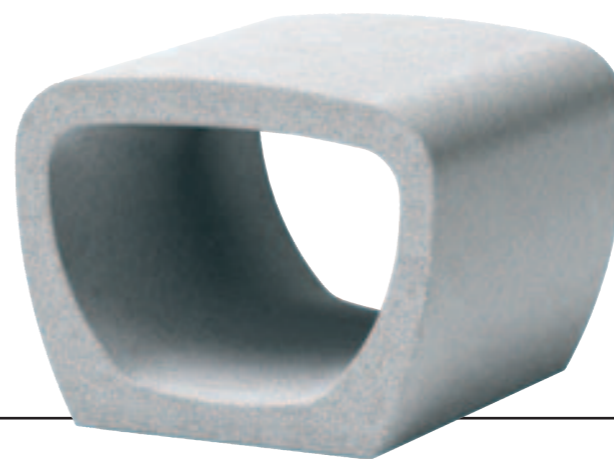
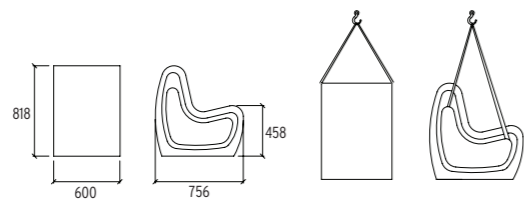

tube cubo | 210 kg |

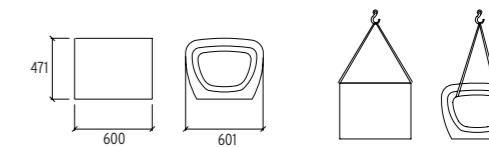

bancos | bancs | benches | bancs

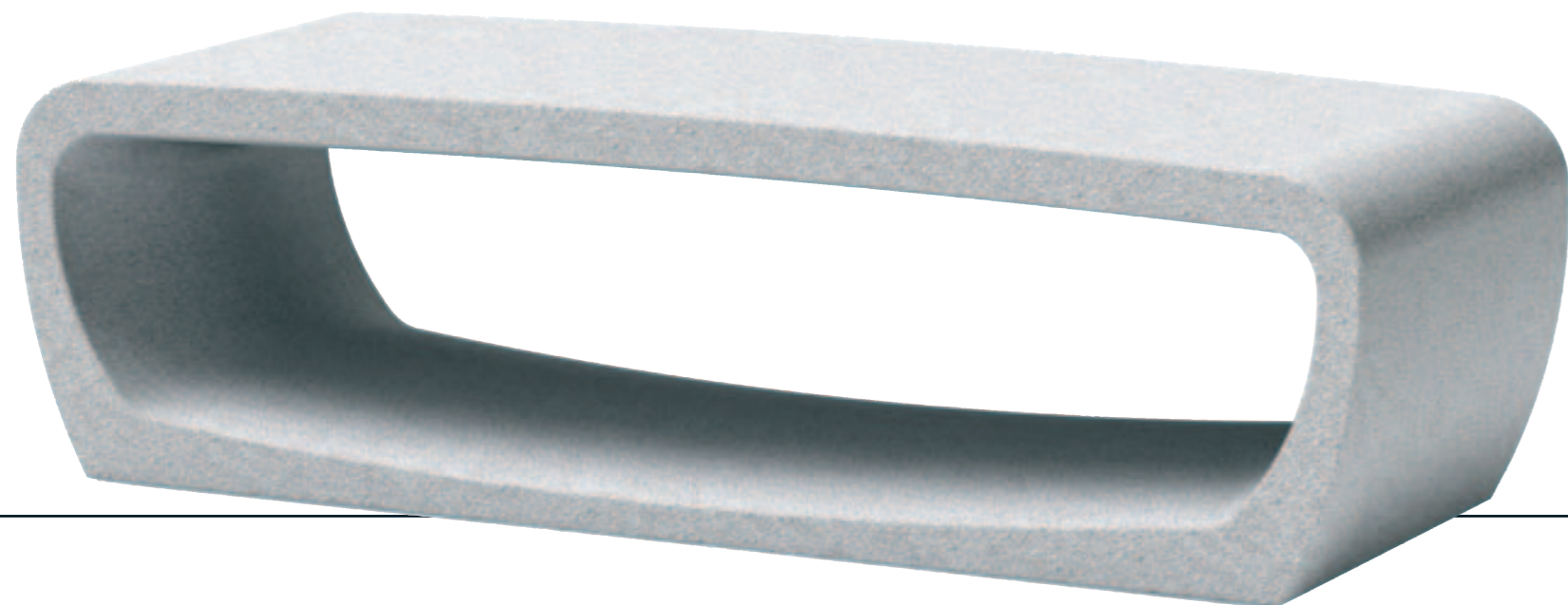

tube tumbona | 510 kg |

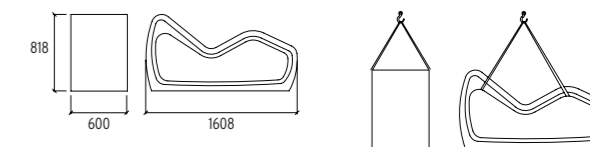

bancos | bancs | benches | bancs

tube banca | 420 kg |

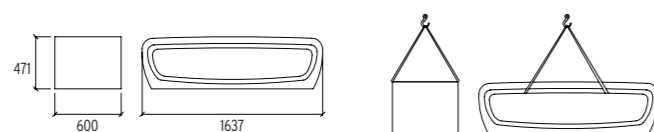

complementary elements

tube limite pag.67

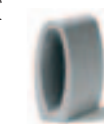

tetris Q | 210 kg |

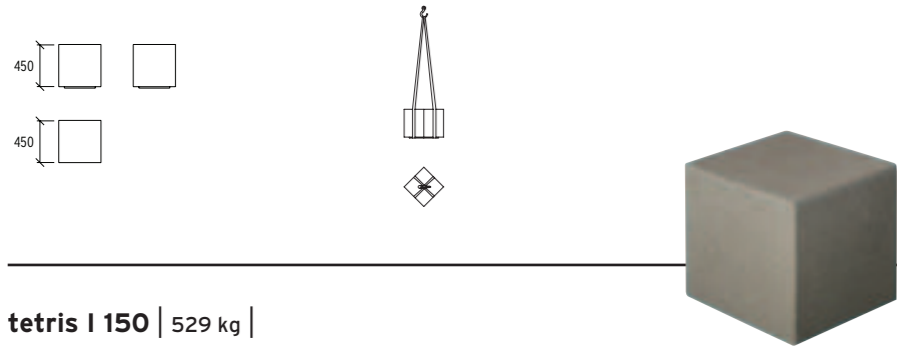

tetris I 150 | 529 kg |

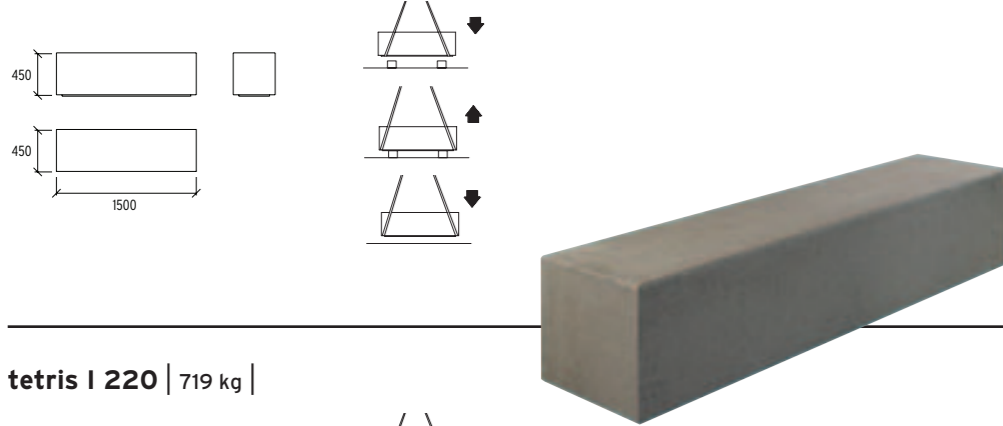

tetris I 220 | 719 kg |

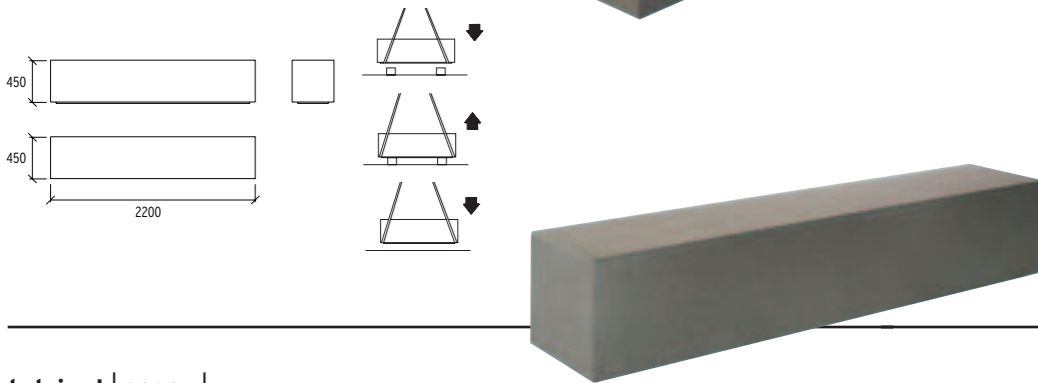

tetris J | 393 kg |

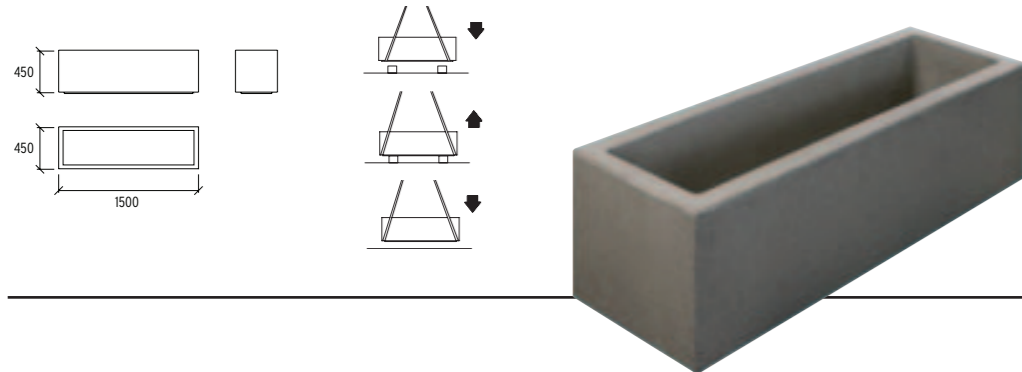

tetris L | 889 kg |

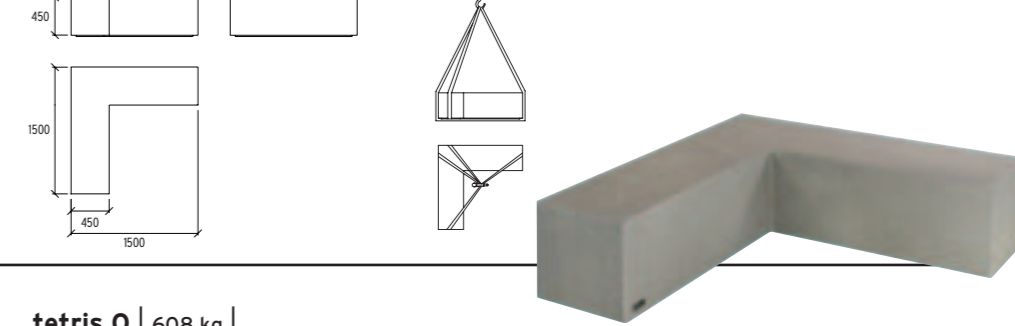

tetris O | 608 kg |

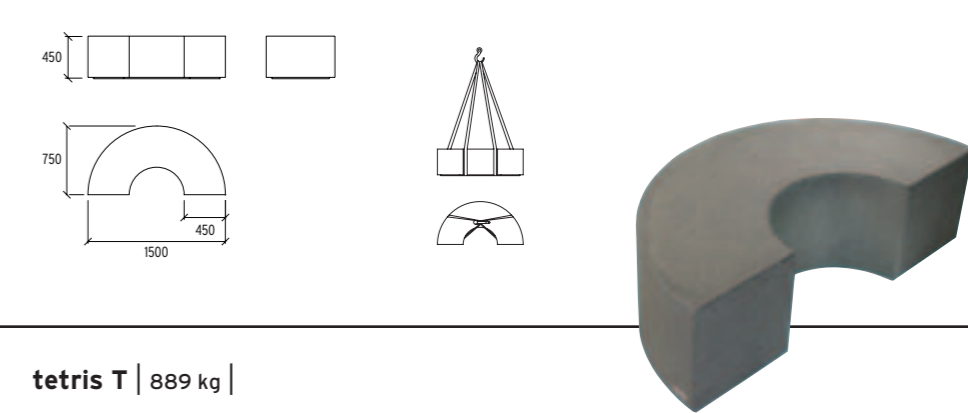

tetris T | 889 kg |

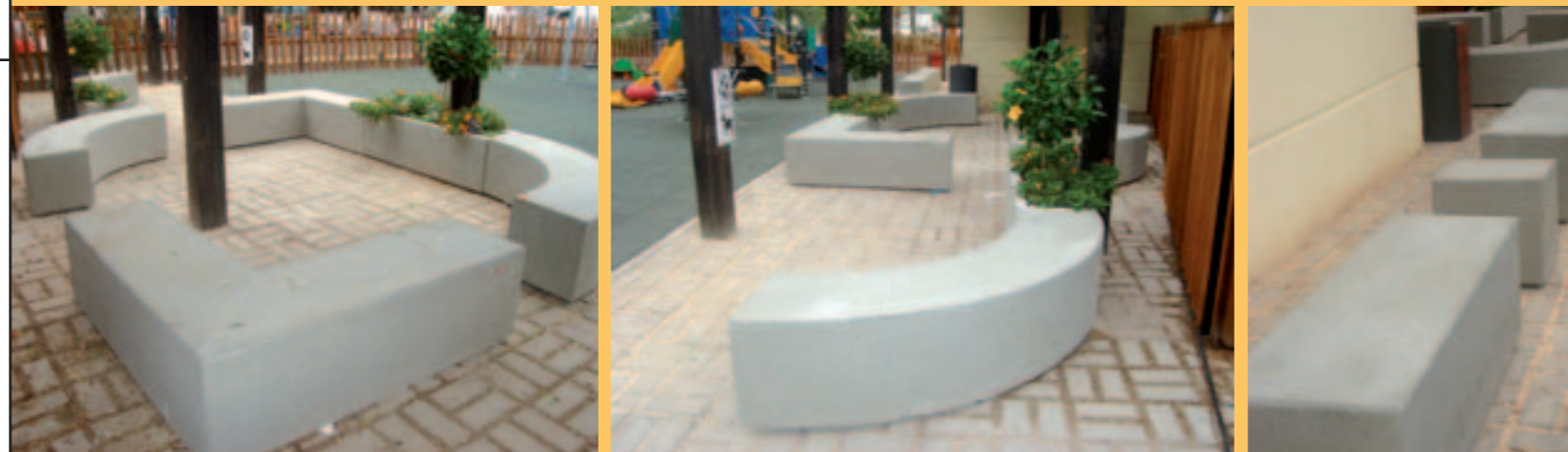
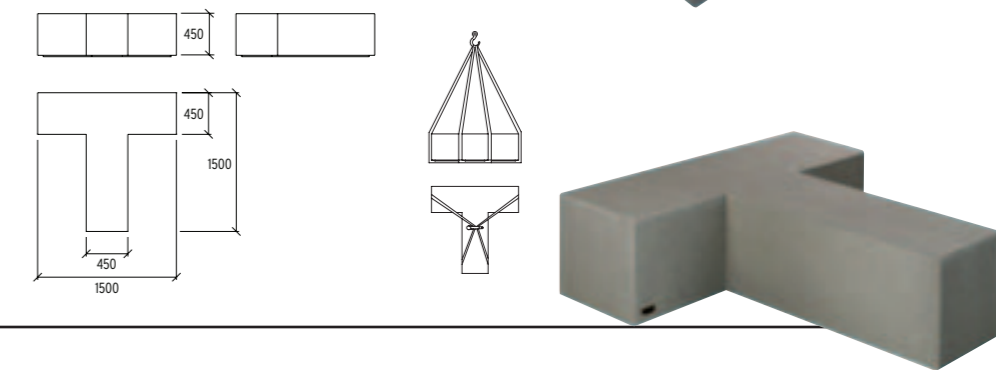

tetris X | 916 kg |

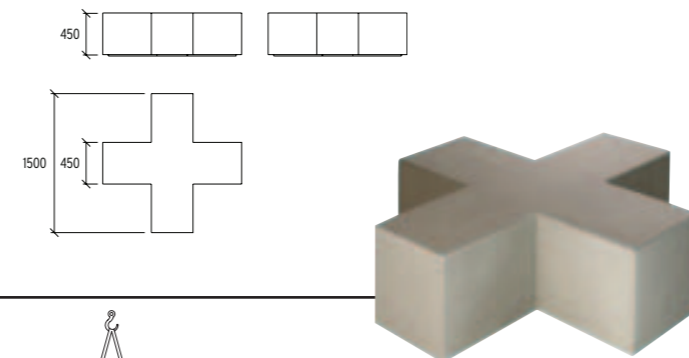

tetris C 30° | 820 kg |

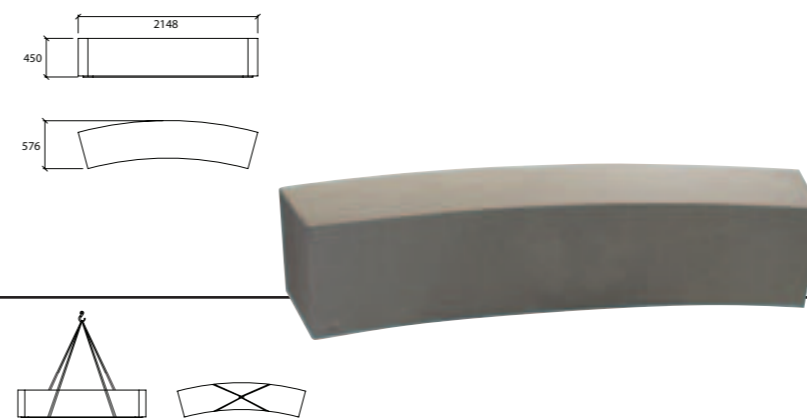

tetris C | 795 kg |

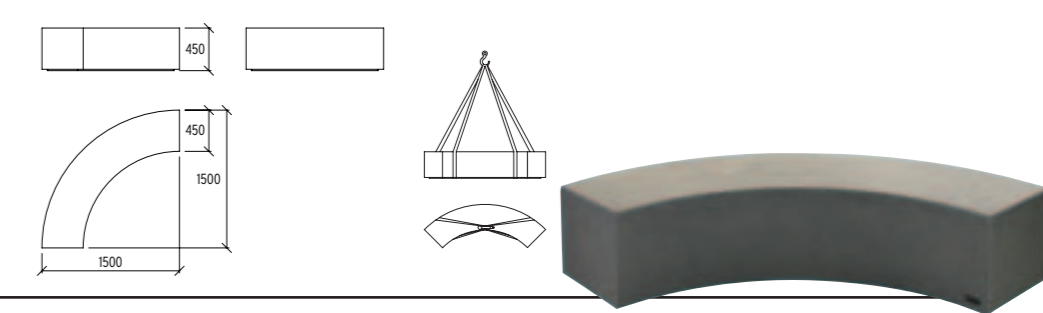

complementary elements

versatil pag. 82





bloop 2m | 640 kg |

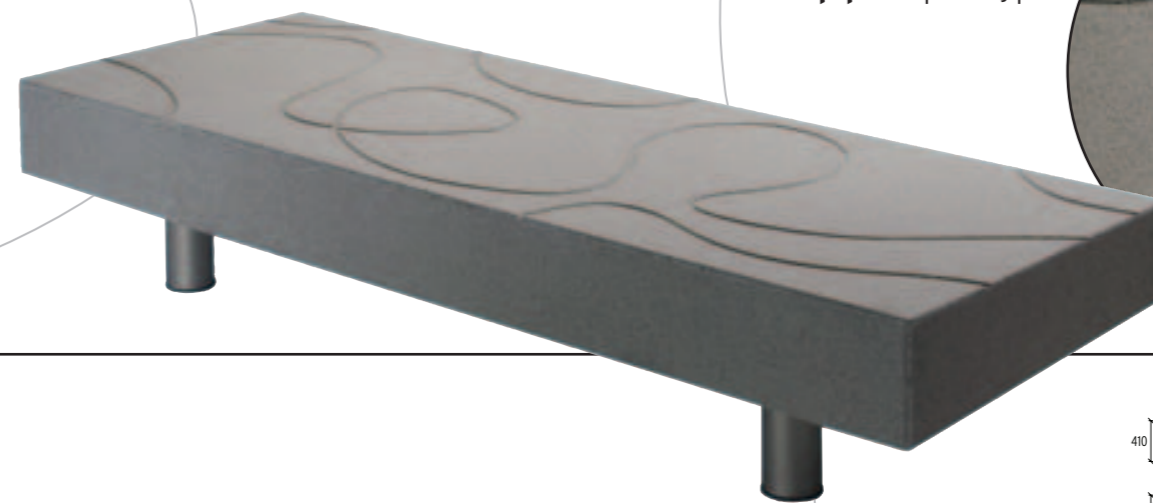
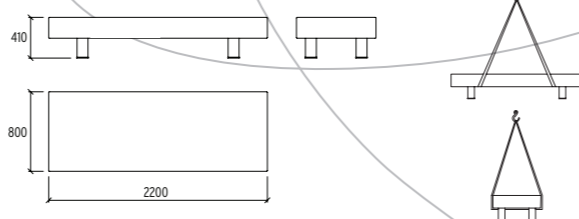

bloop path | 640 kg |

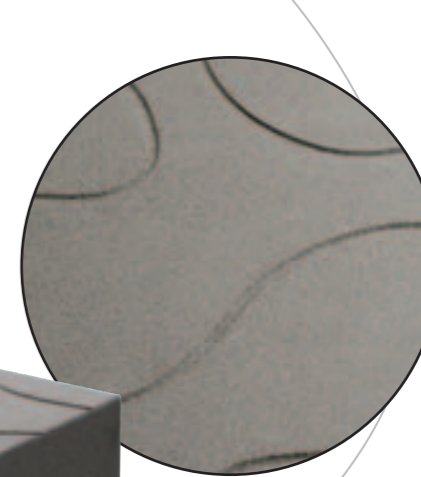
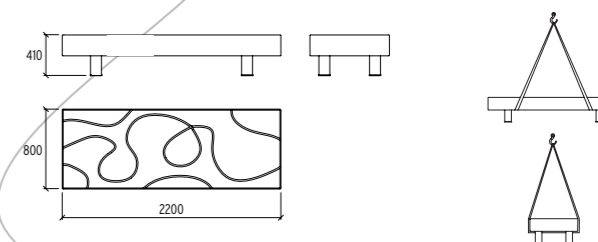



Soportes opcionales, disponibles para todos los modelos bloop y recte.
Suports opcionals, disponibles per a tots els models bloop i recte.
Optional supports, available for all bloops and recte.
Supports optionnels pour tous les modèles bloop et recte.



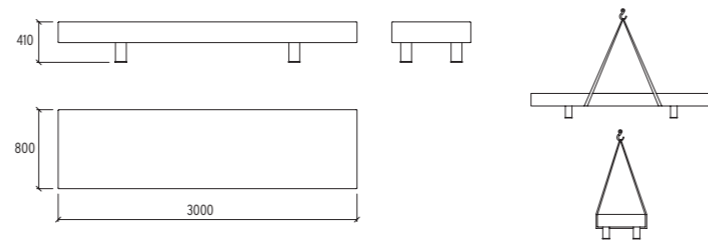

bloop 3m | 875 kg |



- 

Standard de serie - cilindro de aluminio anodizado - autonivelante.
 Standard de sèrie - cilindre d'alumini anoditzat - auto anivellant.
 Standard support : anodizante aluminium cylinder - with a levelling system.
 Support standard : Cylindre en aluminium anodisé avec réglage de mise au niveau.
- 

Ref. qa soporte cuadrado de aluminio anodizado.
 Ref. qa suport quadrat d'alumini anoditzat.
 Ref. qa square support made of anodizante aluminium.
 Réf. qa : Support carré en aluminium anodisé.
- 

Ref. p soporte cilíndrico mecanizado de PEHD (polietileno alta densidad).
 Ref. p suport cilíndric mecanitzat de PEHD (polietilè d'alta densitat).
 Ref. p cylinder mechanized made of HDPE (high density polyethylene).
 Réf. p : Support cylindrique mécanisé en PEHD (polyéthylène d'haute densité).
- 

Ref. pq soporte cuadrado mecanizado de PEHD (polietileno alta densidad).
 Ref. pq suport quadrat mecanitzat de PEHD (polietilè d'alta densitat).
 Ref. pq square support mechanized made of HDPE (high density polyethylene).
 Réf. pq. Support carré mécanisé en PEHD (polyéthylène d'haute densité).

En todos los casos los soportes no se suministran montados.
 En tots els casos els suports no es subministren muntats.
 In every case, the supports are not supplied assembled.
 Dans tous les cas les supports livrés prêt à monter, selon notice.



bloop design > Ton Riera Ubía

bloop rest L | 713 kg |

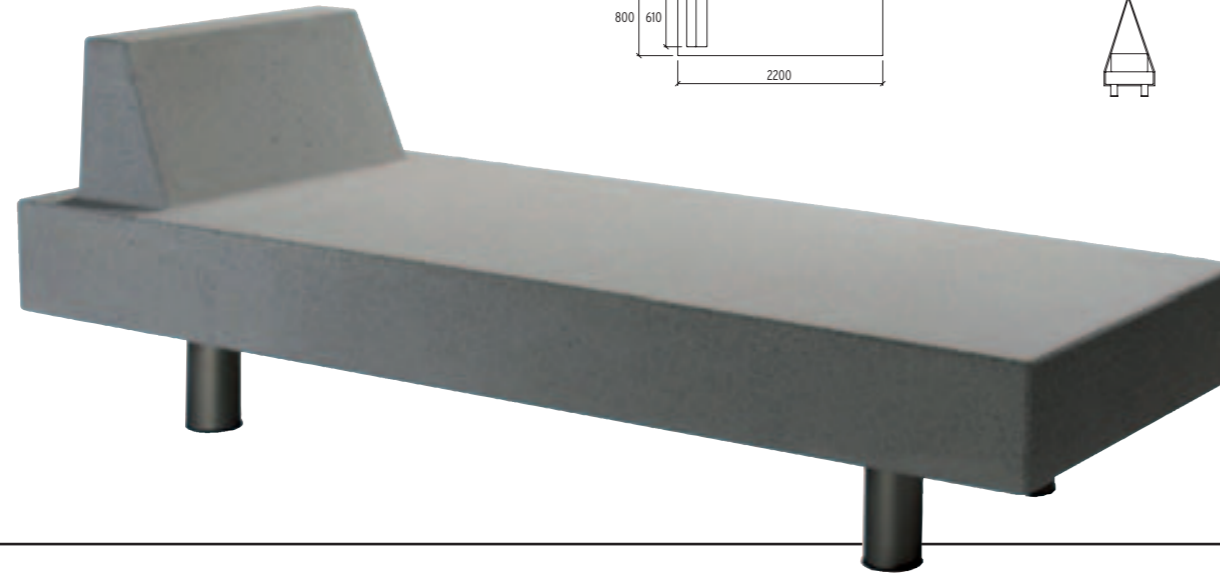
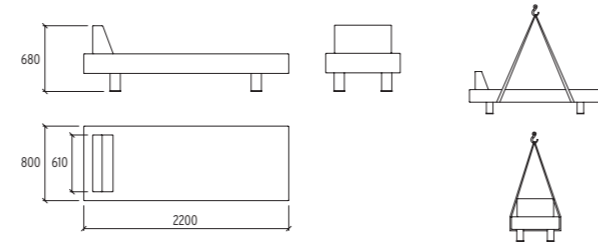

bancos | bancs | benches | bancs

bancos | bancs | benches | bancs

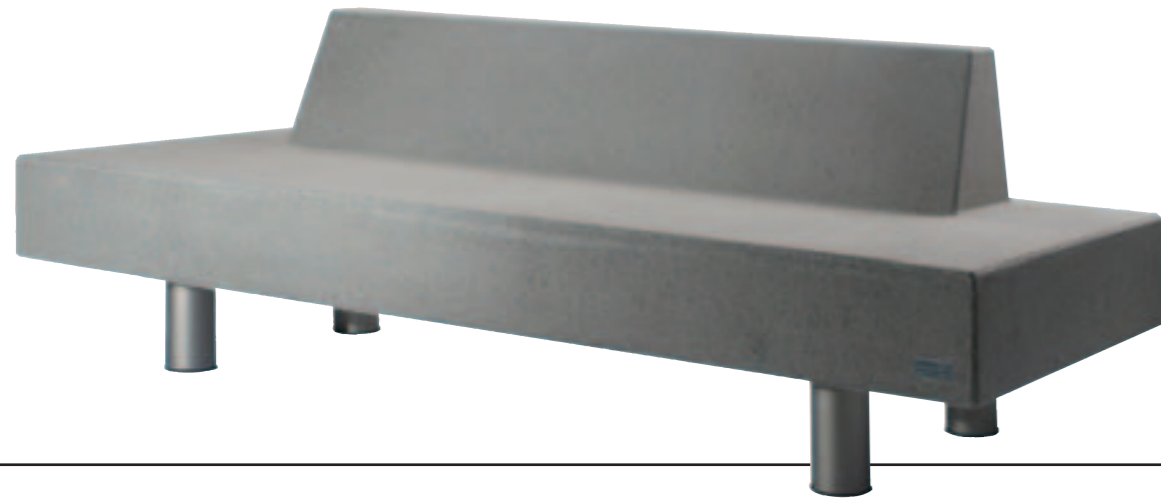

bloop rest C | 813 kg |

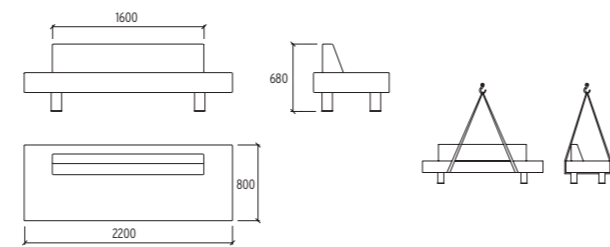

recte | 1105 kg |

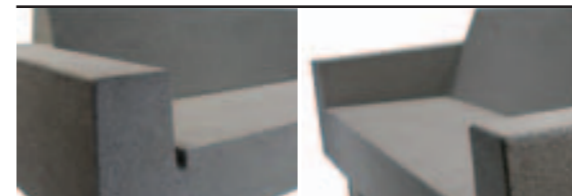
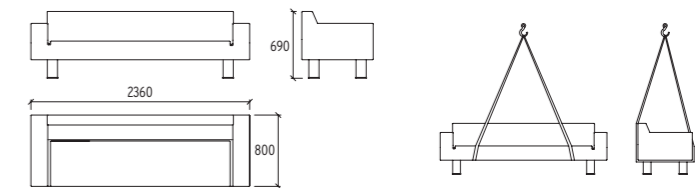



damero | design > Xavier Brucet | 940 kg |

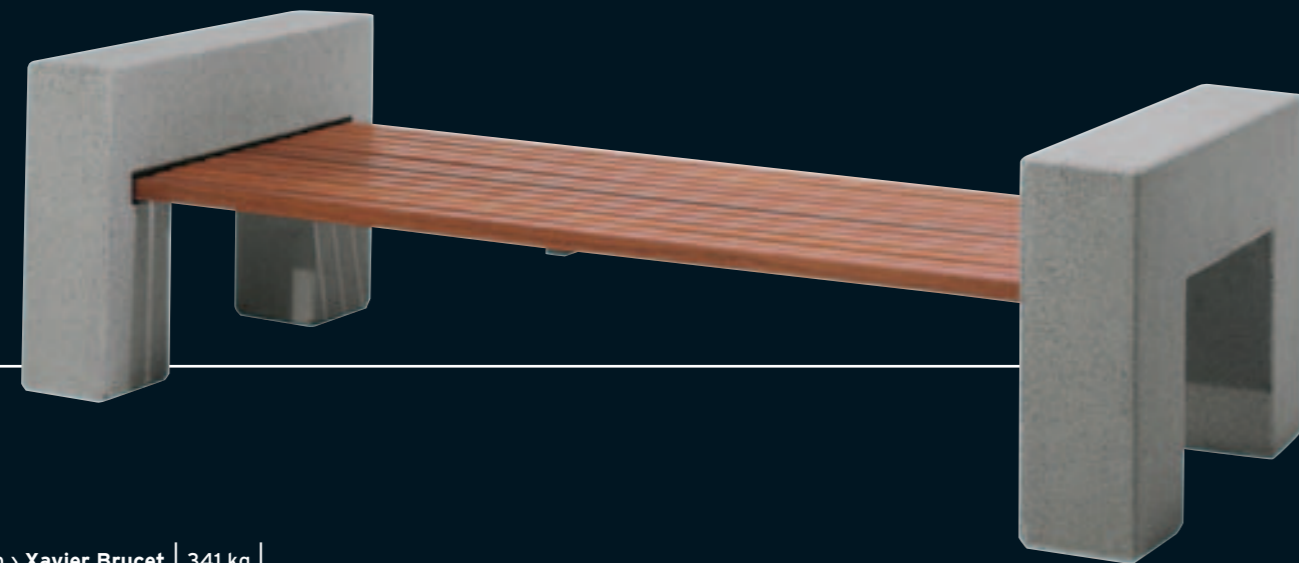
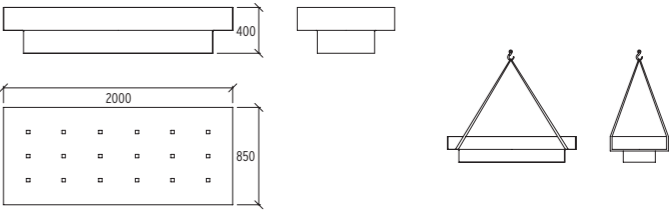

ursus | design > Xavier Brucet | 341 kg |

TROPICAL madera - fusta - wood - bois

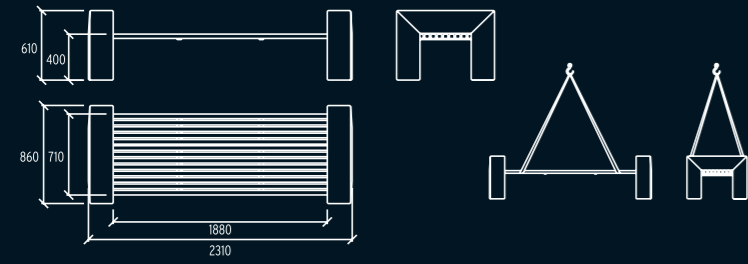

complementary elements

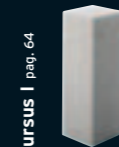

ursus | pag. 64

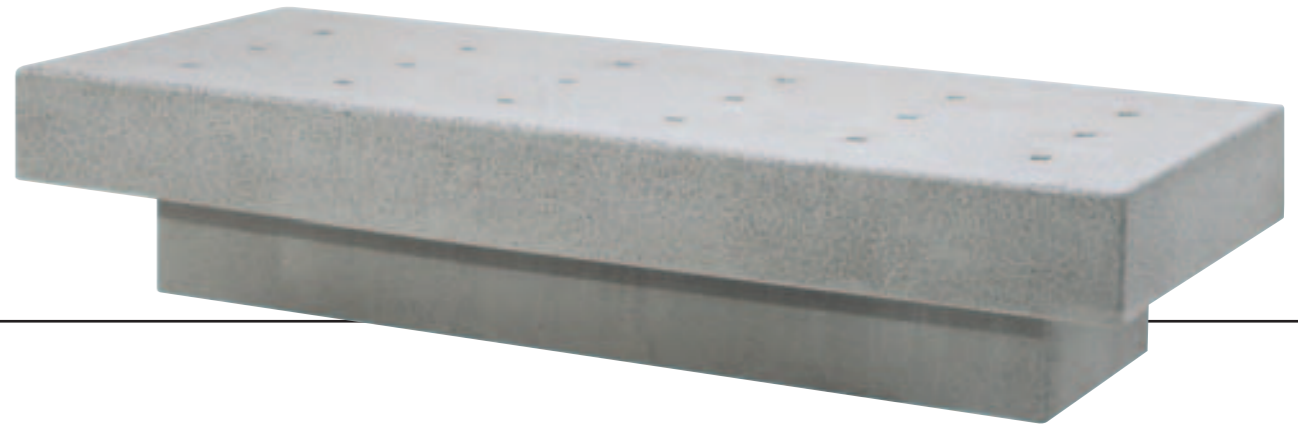

complementary elements



ursus | pag. 64



H cn | design > Ernest Perera | 330 kg |

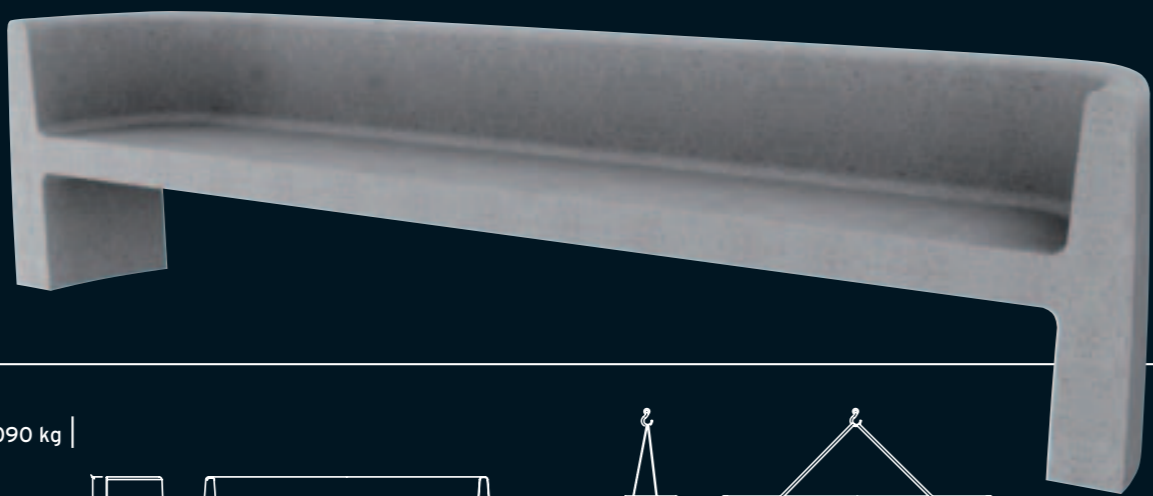
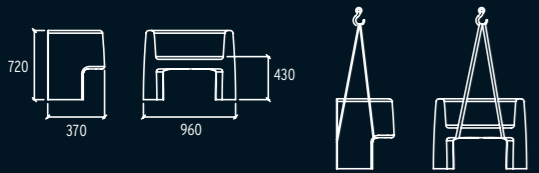

H bn | design > Ernest Perera | 1090 kg |

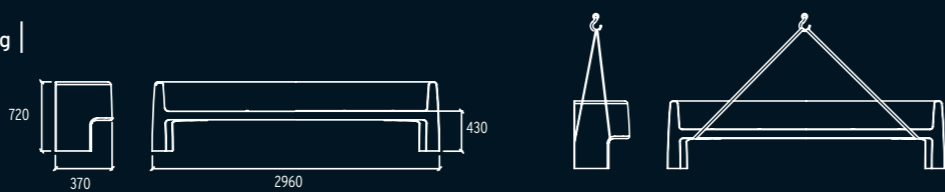

quad b | design > Ernest Perera | 200 kg |

TROPICAL madera - fusta - wood - bois

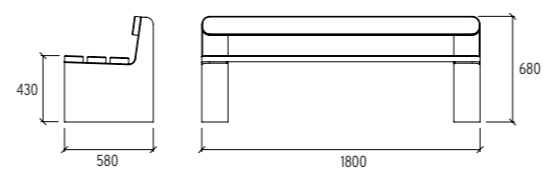

complementary elements



killy 3 | 696 kg |

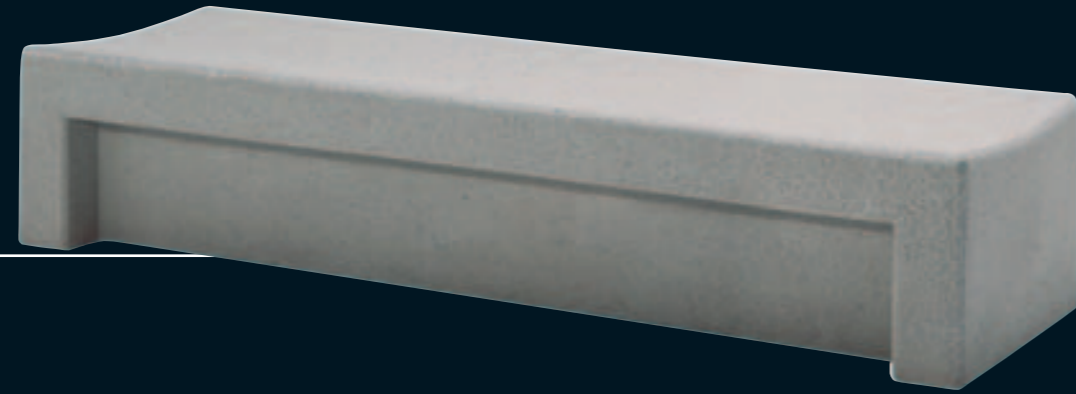

killy 1 | 380 kg |

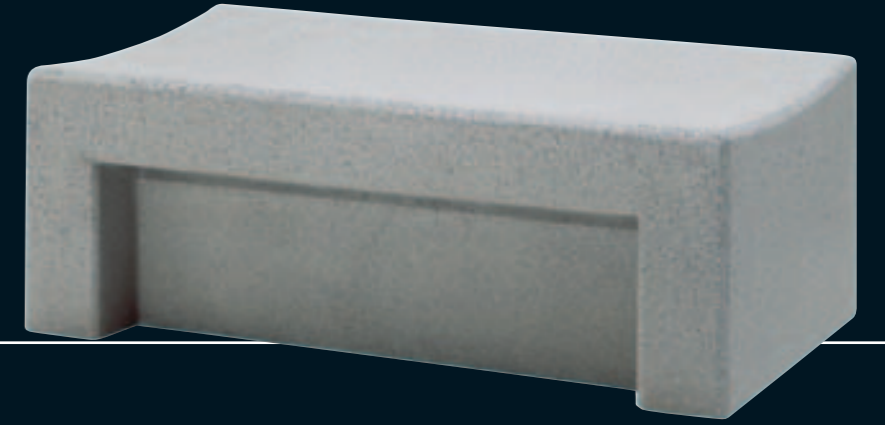

killy 3 F | 696 kg |



killy 1 F | 380 kg |



killy 3 I | 696 kg |

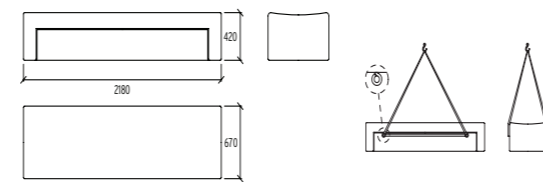

killy 1 I | 380 kg |

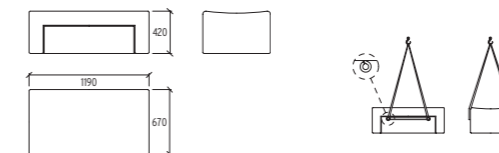

- TROPICAL
- FLANDES



complementary elements



quadrat pag. 54



killy | design > Ton Riera Ubía

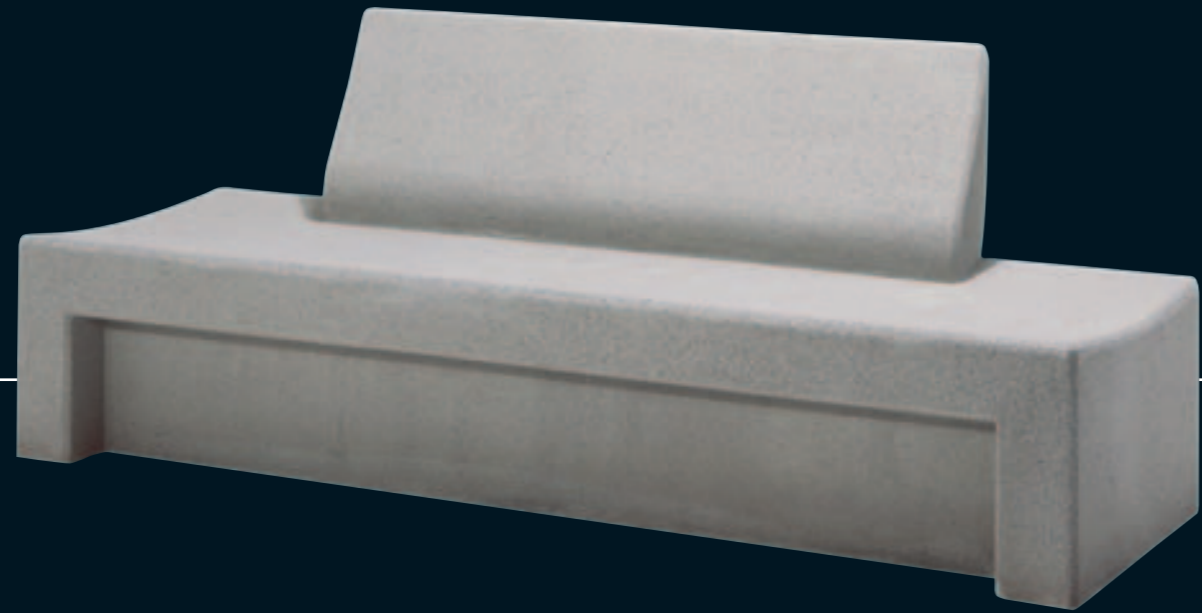

killy 4 | 927 kg |

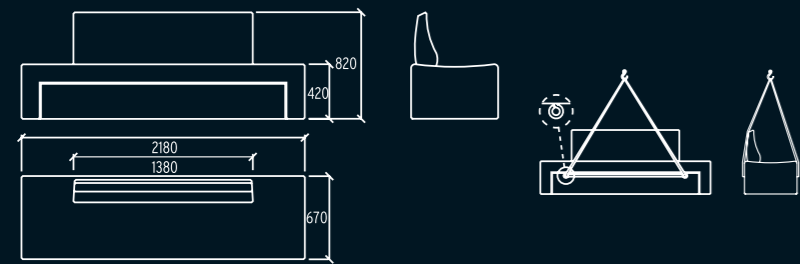

killy 4 I | 927 kg |



killy 4 F | 927 kg |

bancos | bancs | benches | bancs

bancos | bancs | benches | bancs



killy 2 I | 506 kg |



killy 2 F | 506 kg |



killy 2 | 506 kg |

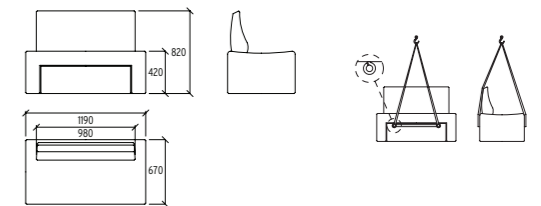

complementary elements



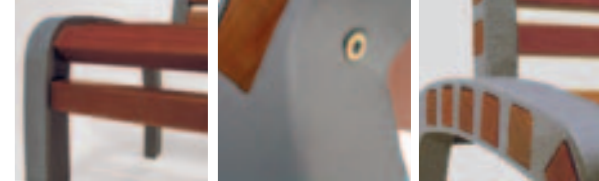

corinto | design > Ton Riera Ubía | 550 kg |

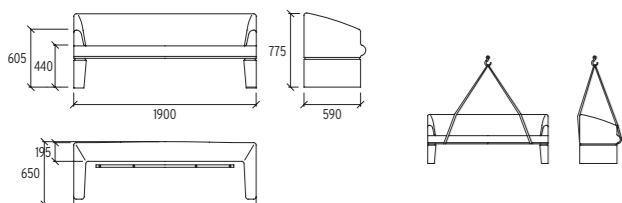

siedi b | design > Oriol Guimerà | 39 kg |

TROPICAL madera - fusta - wood - bois

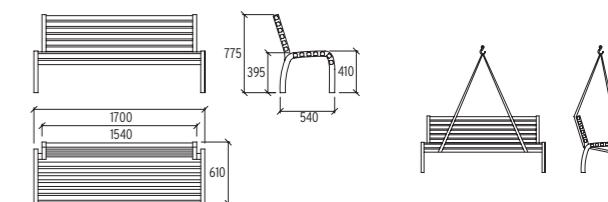

bancos | bancs | benches | bancs

bancos | bancs | benches | bancs



sinus
design > Ton Riera Ubía | 560 kg |

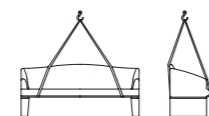
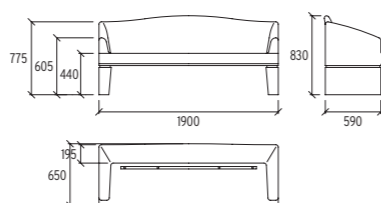

siedi c | design > Oriol Guimerà | 23 kg |

TROPICAL madera - fusta - wood - bois

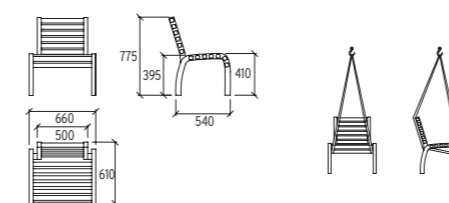

dish
pag. 48

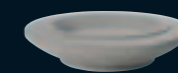

tanit L
pag. 50

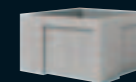

tanit M
pag. 51



tanit S
pag. 51



fuat Q60
pag. 52



fuat Q60 p
pag. 52



fuat Q80
pag. 52



fuat Q80 p
pag. 52



fuat R60
pag. 53



fuat R60 p
pag. 53



fuat R80
pag. 53



fuat R80 p
pag. 53



fuat S85
pag. 53



fuat S85 p
pag. 53



quadrat
pag. 54



quadrat p
pag. 54



circular
pag. 55

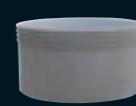

tetris J
pag. 56



fractal
pag. 57



zaphir
pag. 58



pag. 59



Archivos DXF / DWG disponibles en www.magogroup.com [mobiliario urbano]

Arxius DXF / DWG disponibles a www.magogroup.com [mobiliari urbà]

Documents DXF / DWG available on www.magogroup.com [urban items]

Documents DXF / DWG disponibles sur www.magogroup.com [mobilier urbain]

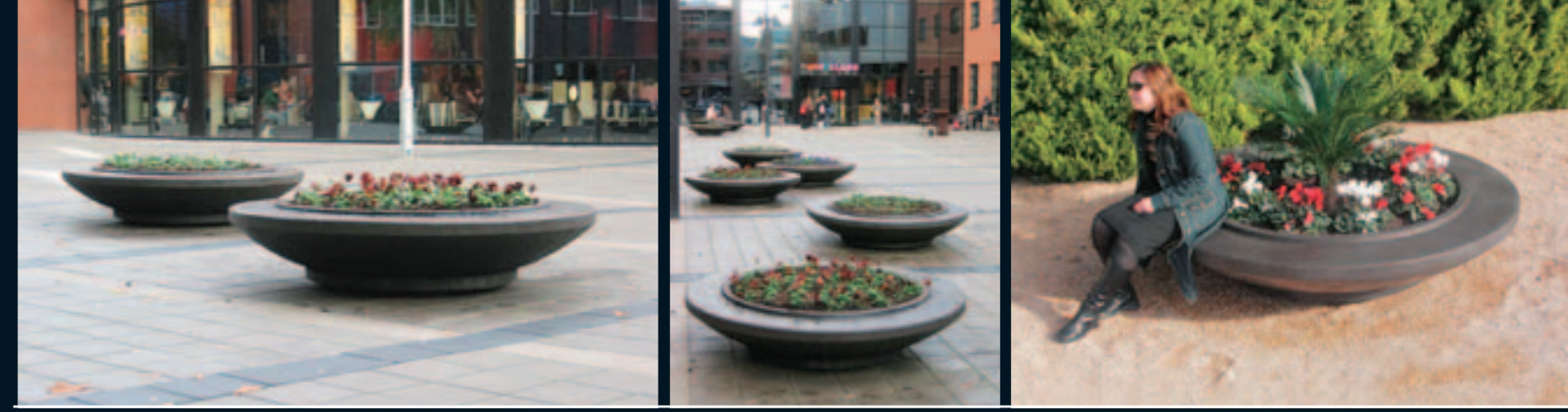

dish | design > Guido Marsille | 931 kg |

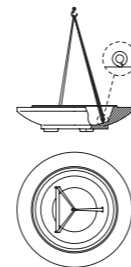
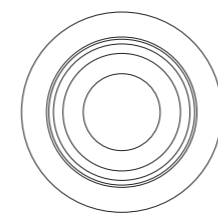
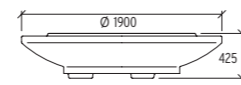

tanit L | 2286 kg |

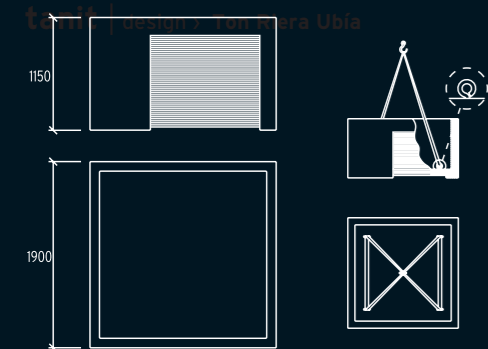

tanit S | 350 kg |

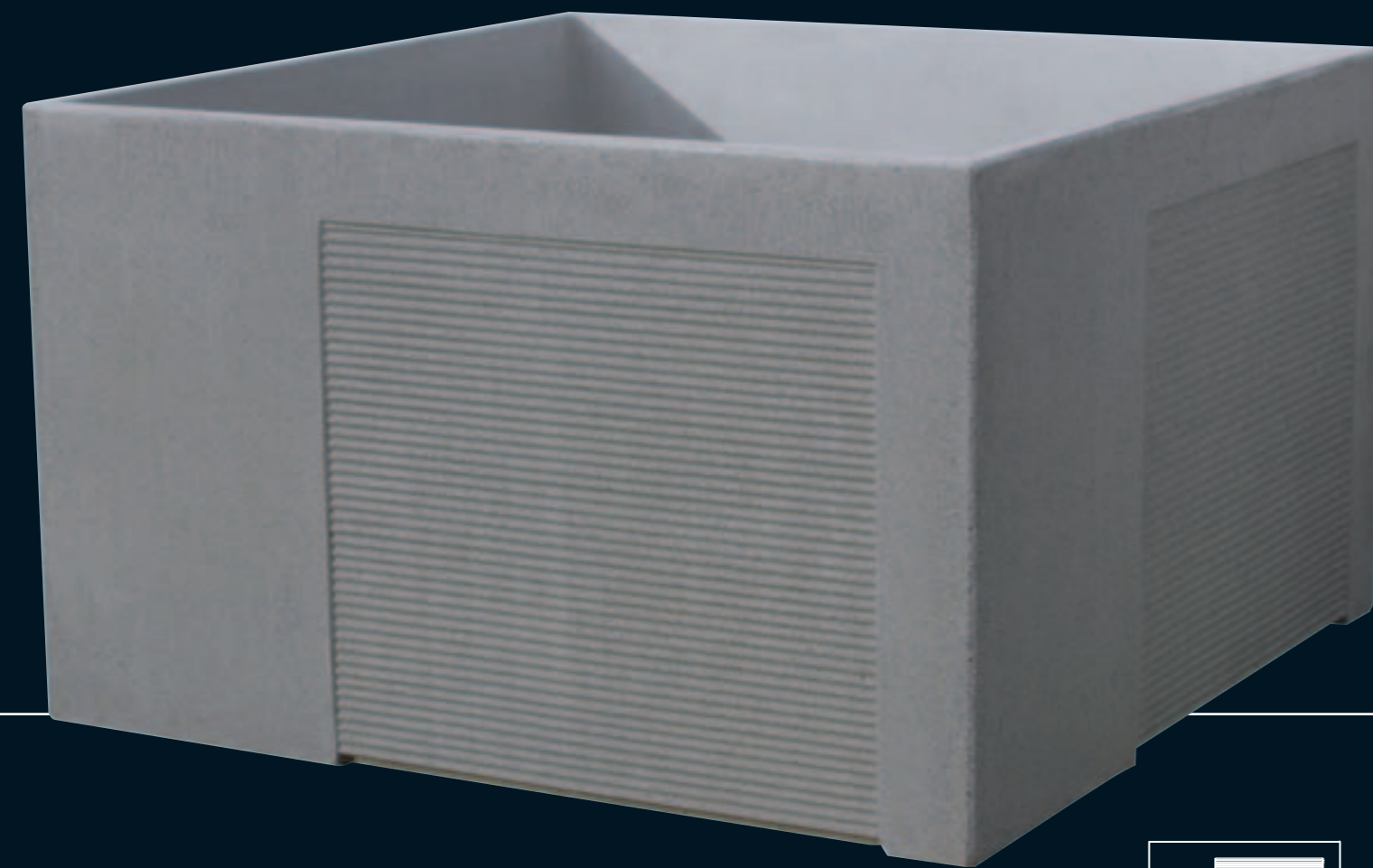
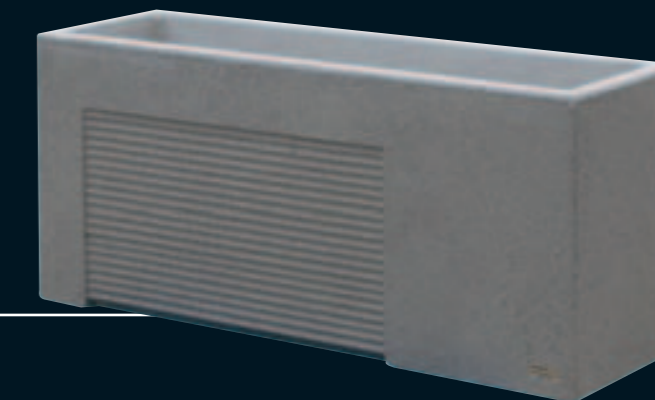
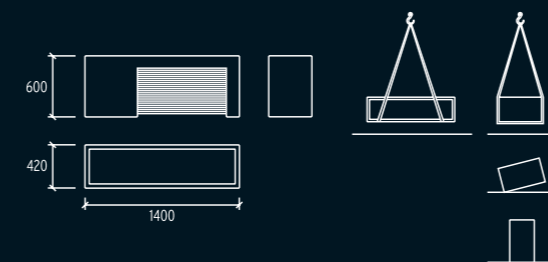

tanit M | 1150 kg |

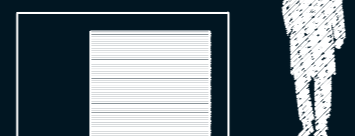
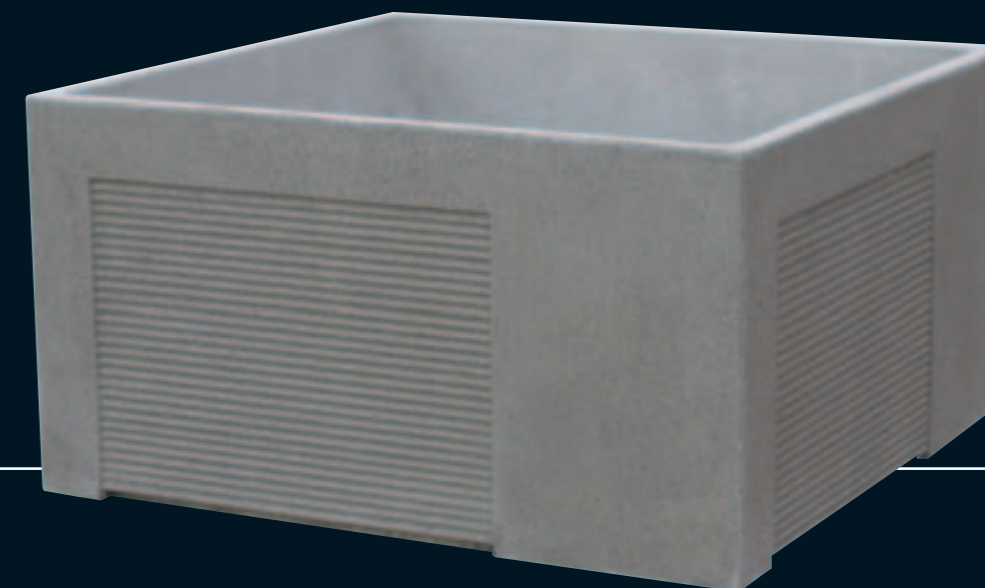
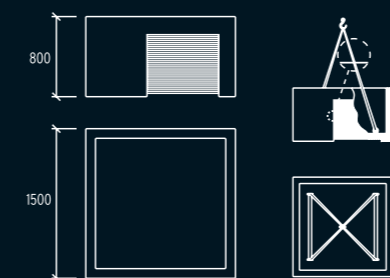

tanit MS | 940 kg |



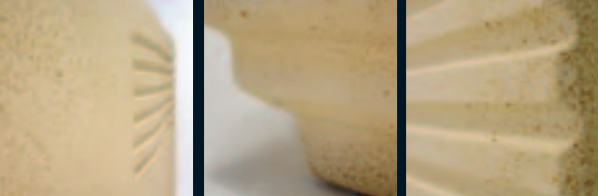

fuat | design > Ton Riera Ubía

fuat Q60 | 1020 kg |

fuat Q80 | 1480 kg |

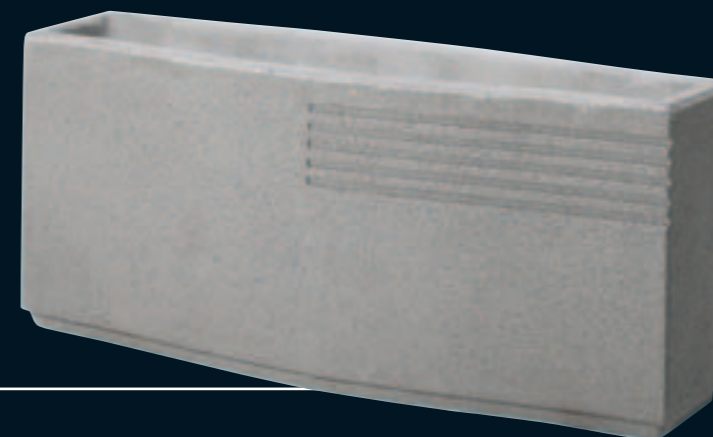
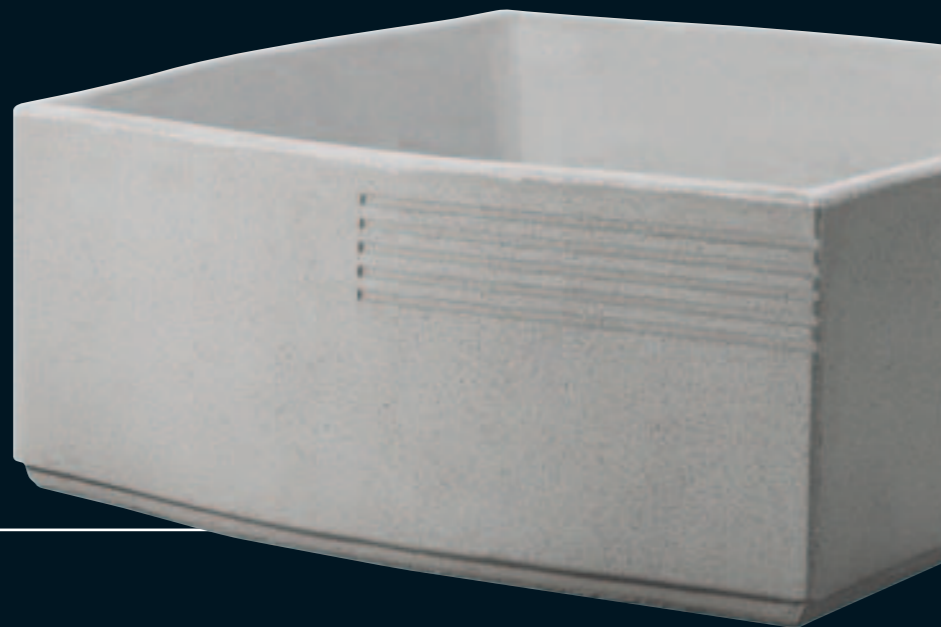

fuat R60 | 380 kg |

fuat R80 | 546 kg |

fuat S85 | 807 kg |



fuat R60 p | 390 kg |

fuat R80 p | 560 kg |

fuat S85 p | 831 kg |

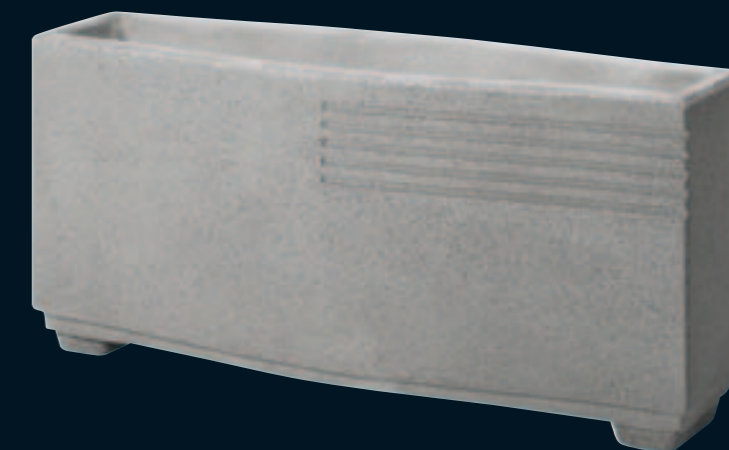

fuat Q60 p | 1100 kg |

fuat Q80 p | 1560 kg |

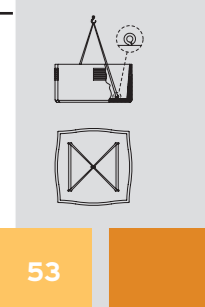
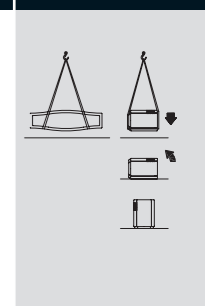
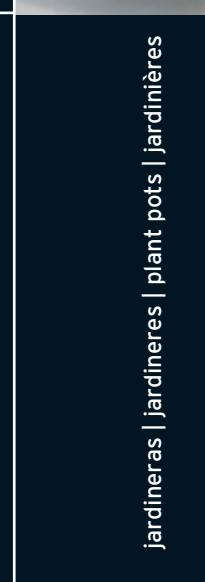
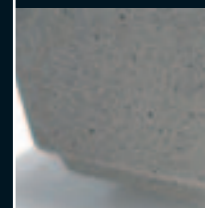
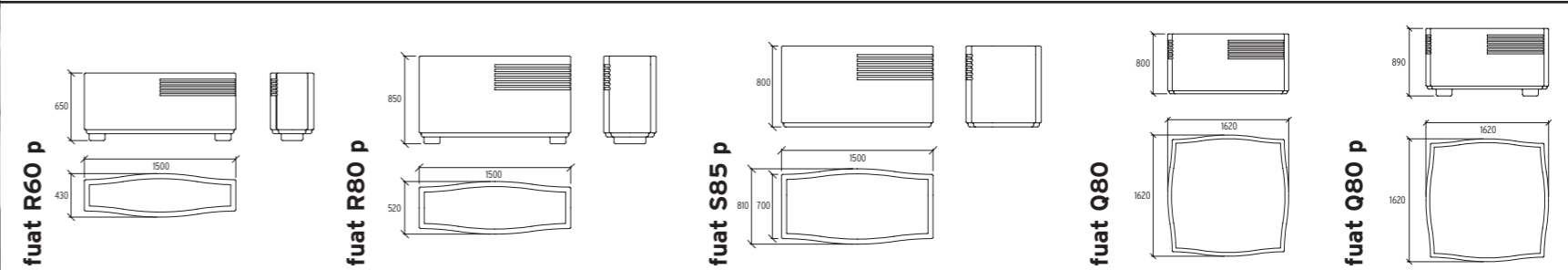
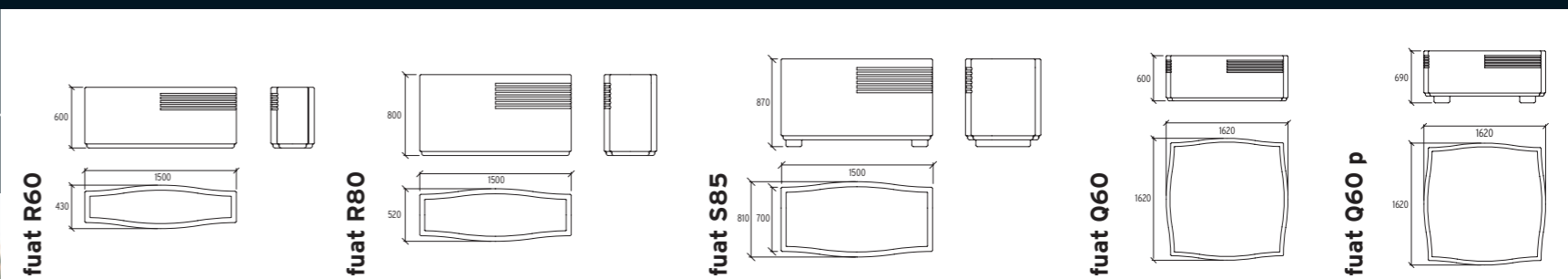

quadrat
design > Ton Riera Ubía | 1040 kg |

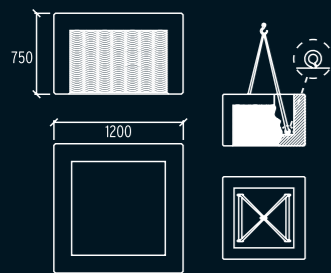

quadrat p
design > Ton Riera Ubía | 1120 kg |

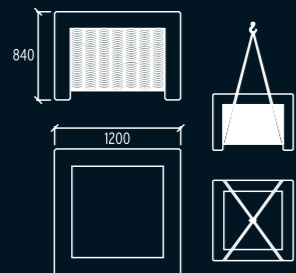

complementary elements



circular | design > Ton Riera Ubía | 825 kg |

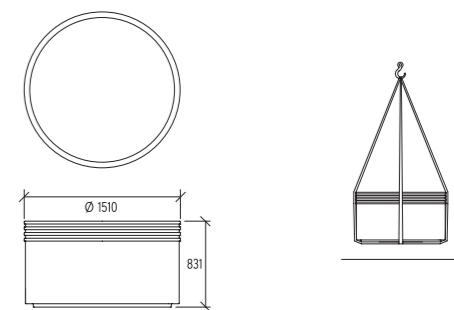

tetris J | design > Roger Albero | 393 kg

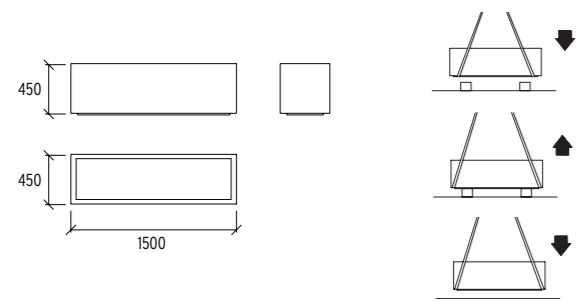

complementary elements

tetris pag. 30-31



versatil pag. 82

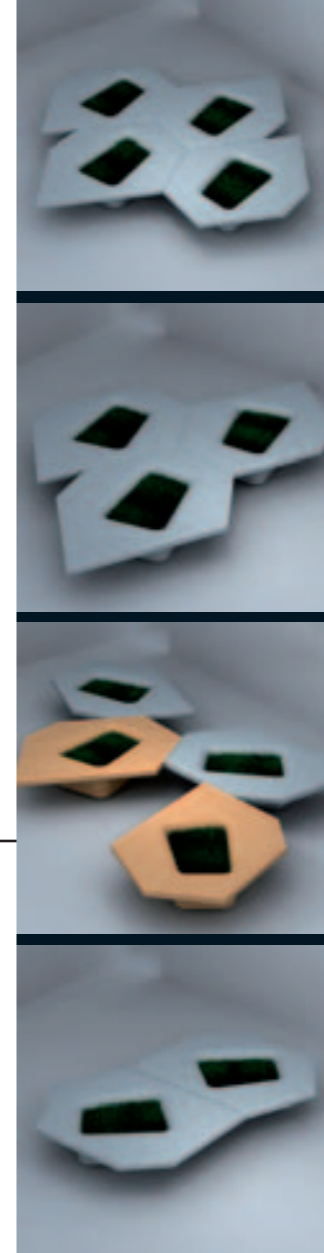
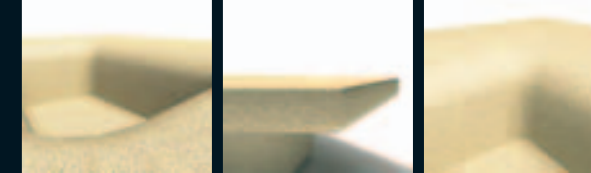

fractal | design > Roger Albero | 550 kg

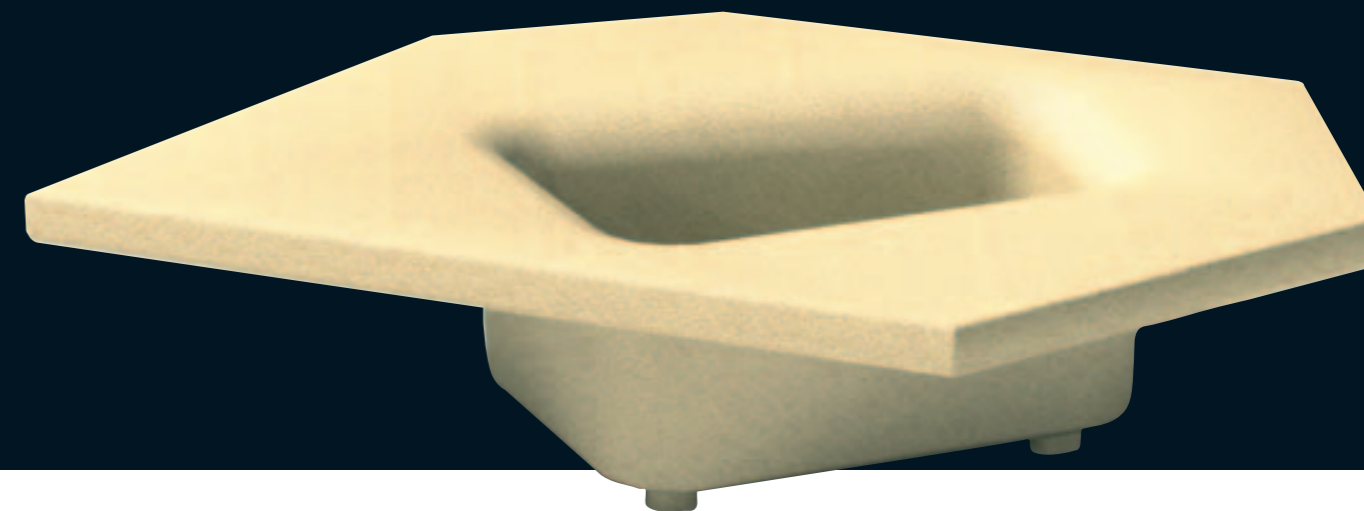
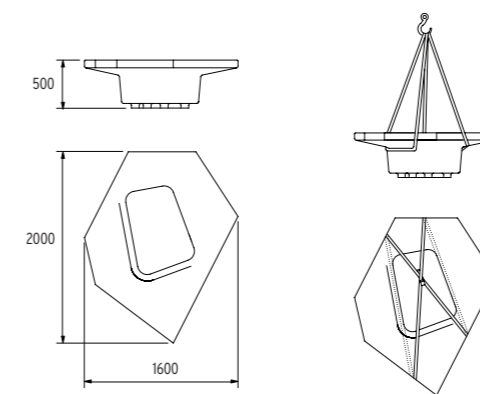

zaphir | design > Ton Riera | 600 kg

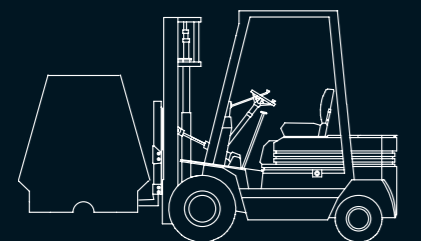
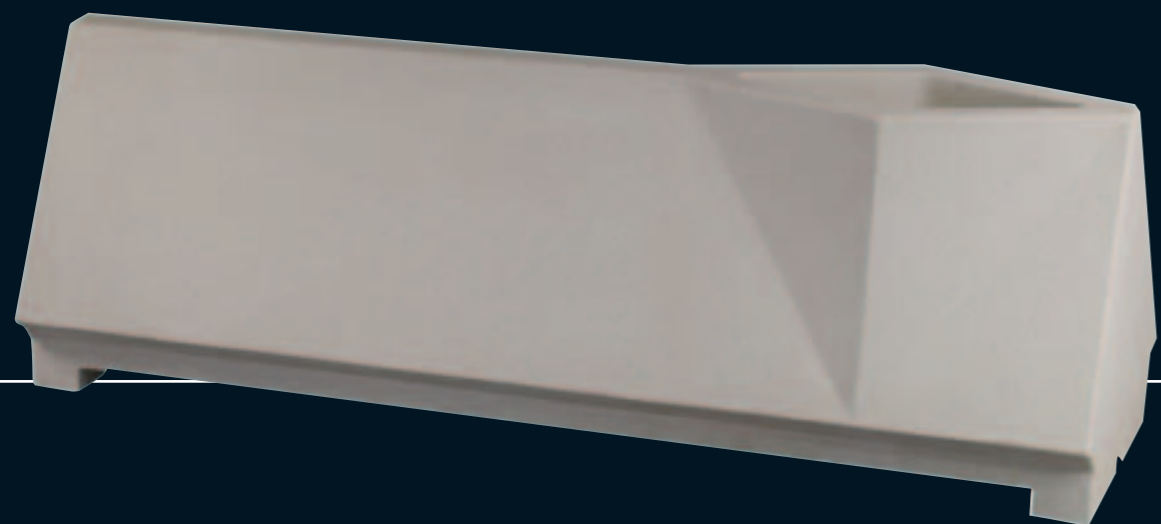
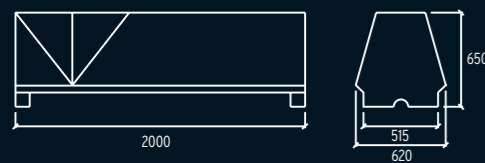

Pino de flandes, tratado al autoclave, color verde natural. Forro interior Geotextil 10% incremento. DISPONEMOS DE MÁS MEDIDAS, INCLUSO FABRICAMOS "A MEDIDA".

Pi de flandes tractat a l'autoclaui, color verd natural. Folradura interior de Geotèxtil 10% d'increment. DISPOSEM DE MÉS MIDES, FINS I TOT FABRIQUEM "A MIDA".

Unbeatable reforestation pinewood. Inside Geotextile liner 10% extra. WE HAVE MORE SIZES AND WE CAN EVEN MANUFACTURE TO MEASURE.

Pin de flandres. Revêtement intérieur en Gèotextile, 10% de supplément. NOUS DISPOSONS DE NOMBREUX MODÈLES, NOUS RÉALISONS NOTAMMENT LA FABRICATION SUR-MESURE.

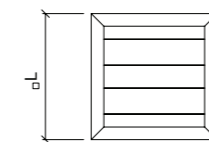
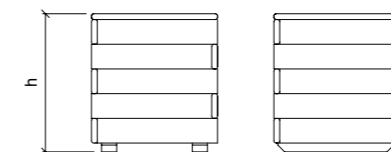

Ref.	LxAxh
F-4040 *	40 x 40 x 40 cm.
F-5050 *	50 x 50 x 50 cm.
F-8080 *	80 x 80 x 80 cm.
F-10010 *	100 x 100 x 100 cm.

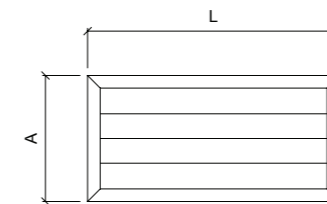
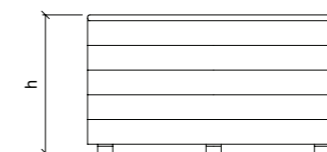

Ref.	LxAxh
F-10040 *	100 x 40 x 40 cm.
F-15040 *	150 x 40 x 40 cm.
F-10050 *	100 x 50 x 50 cm.
F-15050 *	150 x 50 x 50 cm.

Archivos DXF / DWG disponibles en www.magogroup.com [mobiliario urbano]
Arxius DXF / DWG disponibles a www.magogroup.com [mobiliari urbà]
Documents DXF / DWG available on www.magogroup.com [urban items]
Documents DXF / DWG disponibles sur www.magogroup.com [mobilier urbain]

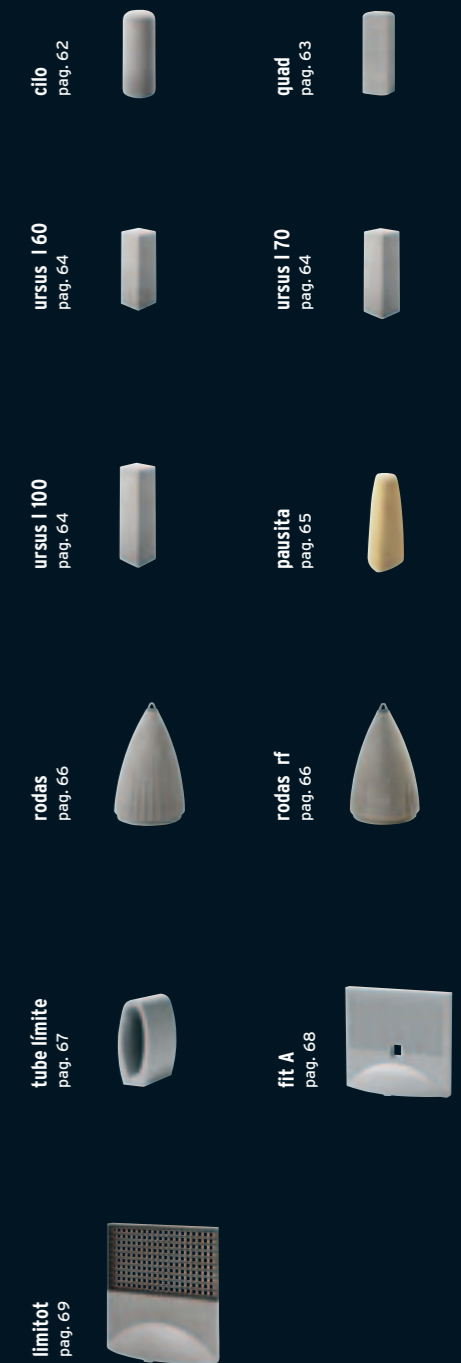



quad | design › Ernest Perera | 113 kg |

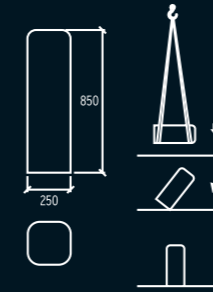

cilo | design › Ernest Perera | 67 kg |



límites | límits | limits | limites

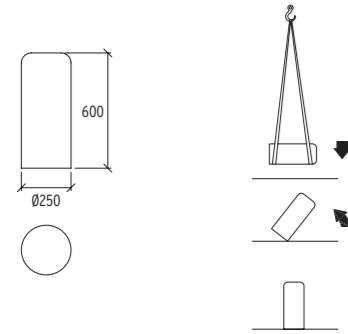

Detalle anclaje Ø 16 mm. El anclaje **no se suministra montado** en el elemento.
 Detall ancoratge Ø 16 mm. L'ancoratge **no es subministra muntat** a l'element.
 Detail of the support Ø 16 mm. The support **is not supplied fitted** to the element.
 Détail de l'ancrage Ø 16 mm. L'ancrage **n'est pas fournit monté**.

límites | límits | limits | limites

complementary elements





Detalle anclaje Ø 16 mm. El anclaje **no se suministra montado** en el elemento.
 Detall ancoratge Ø 16 mm. L'ancoratge **no es subministra muntat** a l'element.
 Detail of the support Ø 16 mm. The support **is not supplied fitted** to the element.
 Détail de l'ancrage Ø 16 mm. L'ancrage **n'est pas fournit monté**.



ursus I 60 | 55 kg |

ursus I 70 | 68 kg |

ursus I 100 | 101 kg |

design > Xavier Bruçet



pausita | design > Oriol Guimerà | 66 kg |

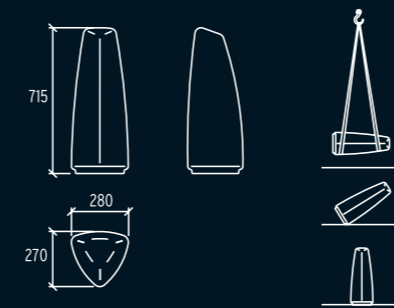

Detalle anclaje Ø 16 mm. El anclaje **no se suministra montado** en el elemento.
 Detall ancoratge Ø 16 mm. L'ancoratge **no es subministra muntat** a l'element.
 Detail of the support Ø 16 mm. The support **is not supplied fitted** to the element.
 Détail de l'ancrage Ø 16 mm. L'ancrage **n'est pas fournit monté**.

límits | límits | límits | límits

límits | límits | límits | límits

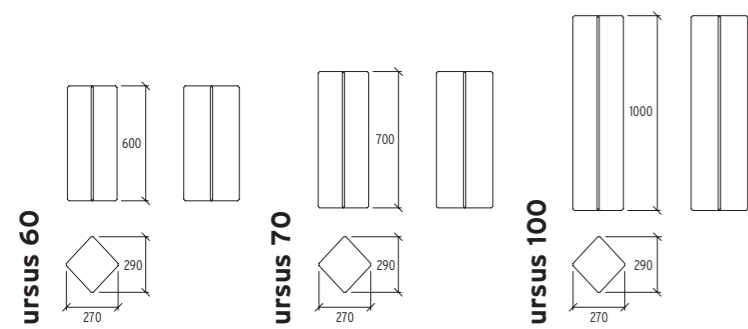

complementary elements

damero pag.37



ursus pag.36



complementary elements

pausa pag.19





rodas | design > Ton Riera Ubía

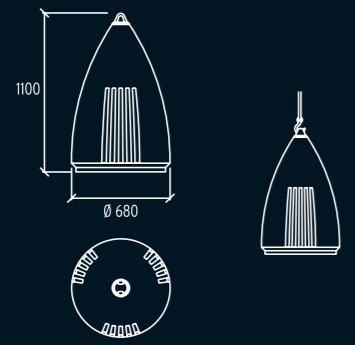

rodas | 497 kg |

rodas rf | 497 kg |

complementary elements



tube límite | design > Roger Albero | 220 kg |

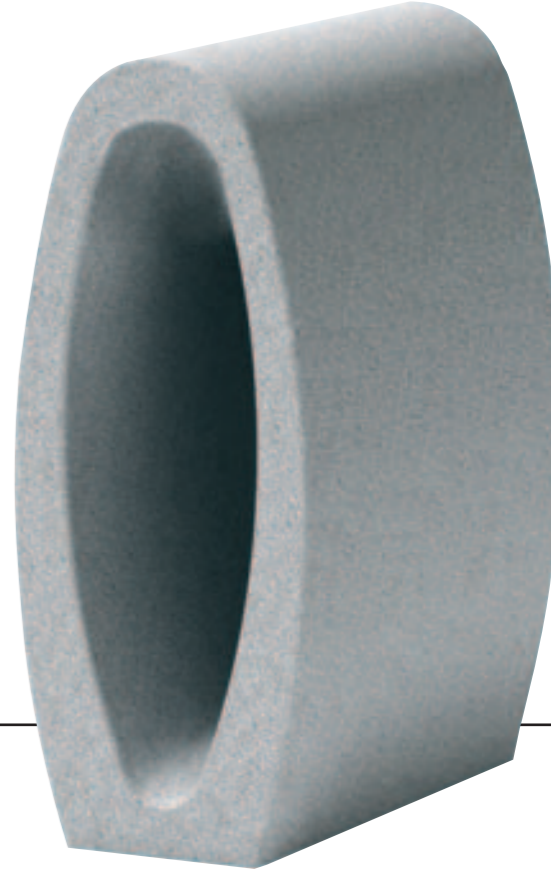
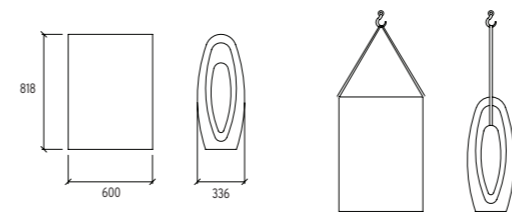

complementary elements

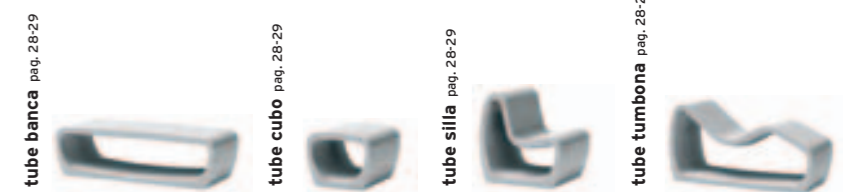

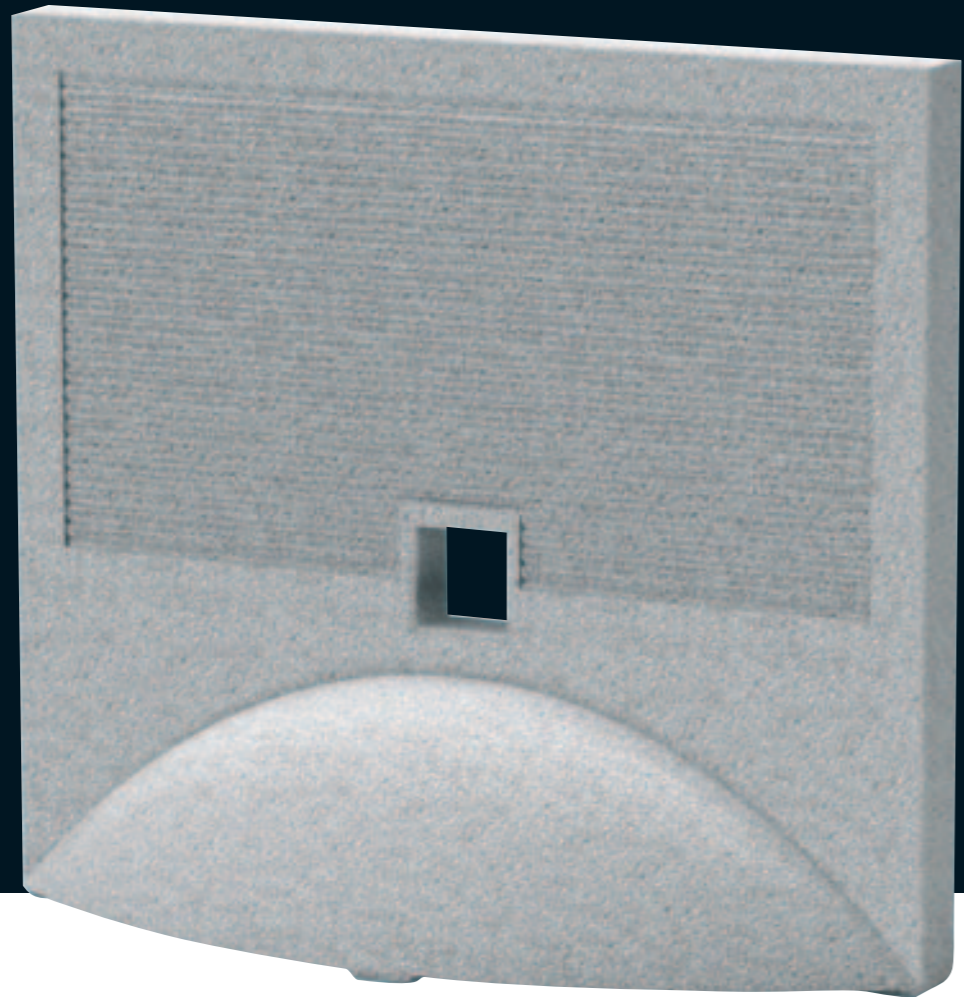
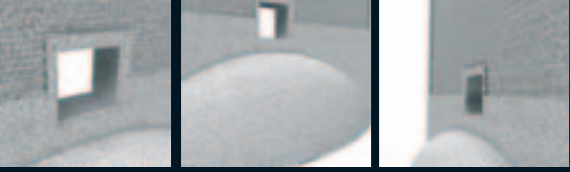

fit A | design > Ton Riera Ubía | 410 kg |

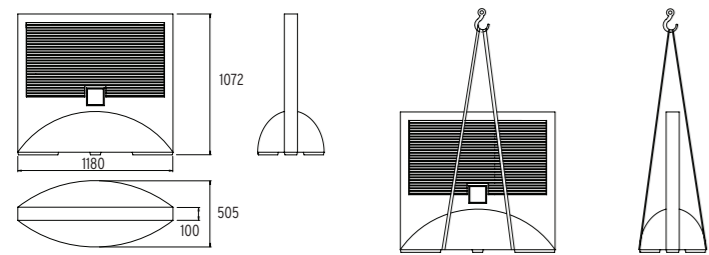

límites | limits | límites | limits | límites

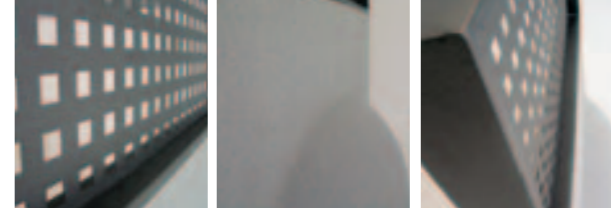

limitot | design > Ton Riera Ubía | 283 kg |

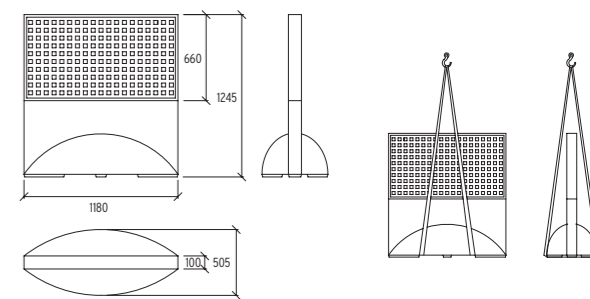
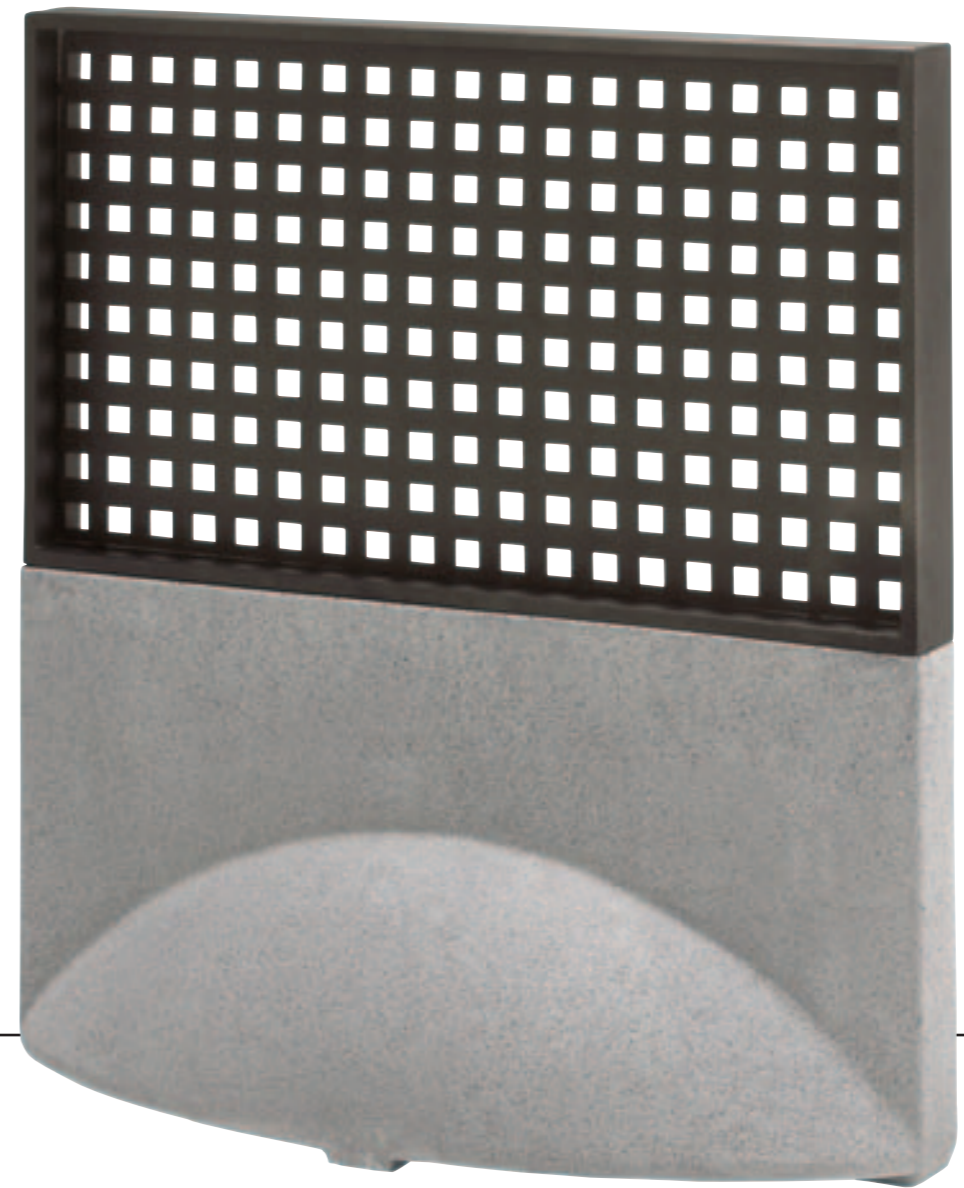

límites | limits | límites | limits | límites



Archivos DXF / DWG disponibles en www.magogroup.com [mobiliario urbano]
 Arxius DXF / DWG disponibles a www.magogroup.com [mobiliari urbà]
 Documents DXF / DWG available on www.magogroup.com [urban items]
 Documents DXF / DWG disponibles sur www.magogroup.com [mobilier urbain]

balisa JM
pag. 72



TV
pag. 75



portic
pag. 77



paros
pag. 79



quad p
pag. 81



versatil
pag. 82



pass
pag. 84



via lactea
pag. 74

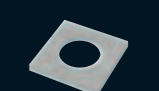

cap i cua
pag. 76

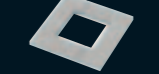

sunion
pag. 78



quad bike
pag. 80



quad pt
pag. 81



icon
pag. 83

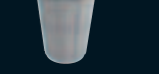

+vorerera
pag. 86





balisa JM

design > Jordi Miralles, Jordi Miró
80 kg



Estudio luminotécnico | Estudi luminotècnic Light study | Étude lumineuse



Diagrama polar | Diagrama polar | Polar graph | Diagramme polaire



Simulación luminosa | Simulació lluminosa
Luminous simulation | Simulation lumineuse

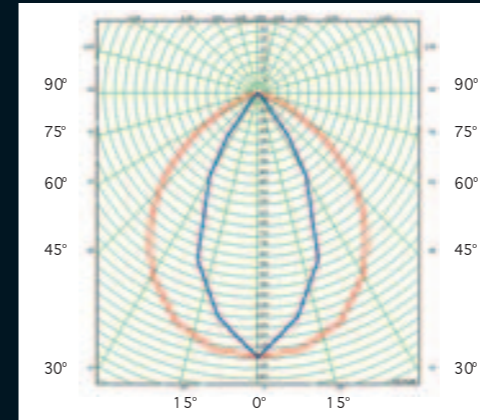
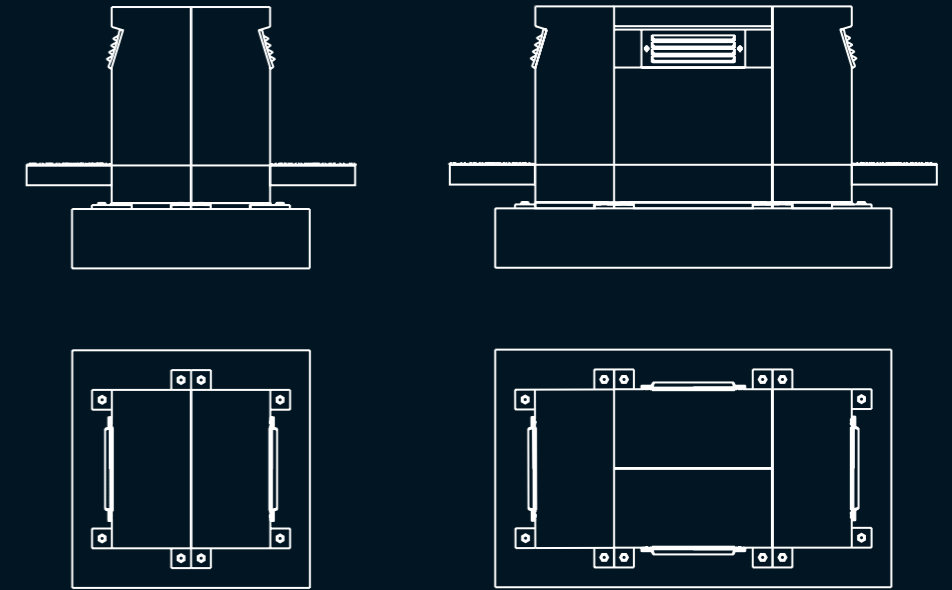

Luminaria Carandini ref. LRE-18. Lámpara NO incluida en el precio, recomendamos una lámpara fluorescente compacta de 18 w.
Luminària Carandini ref. LRE-18. Làmpada NO inclosa al preu, recomanem una làmpada fluorescent compacta de 18 w.
Carandini Light fitting ref. LRE-18. Bulb NOT included in the price, we recommend a compact fluorescent 18 w bulb.
Luminaire Carandini ref. LRE-18. Lampe non incluse dans le prix, nous recommandons une lampe fluorescente compacte de 18 w.



via lactea 120 | 212 kg |

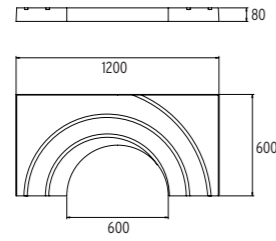

via lactea 160 | 370 kg |

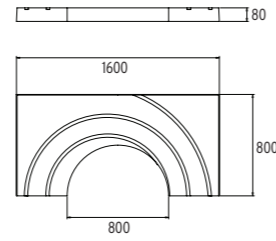

via lactea | design > Ernest Perera

miscelânea | miscelânea | miscelânea | miscelânea | divers



TV 120 | 238 kg |

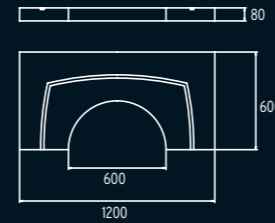

TV 160 | 374 kg |

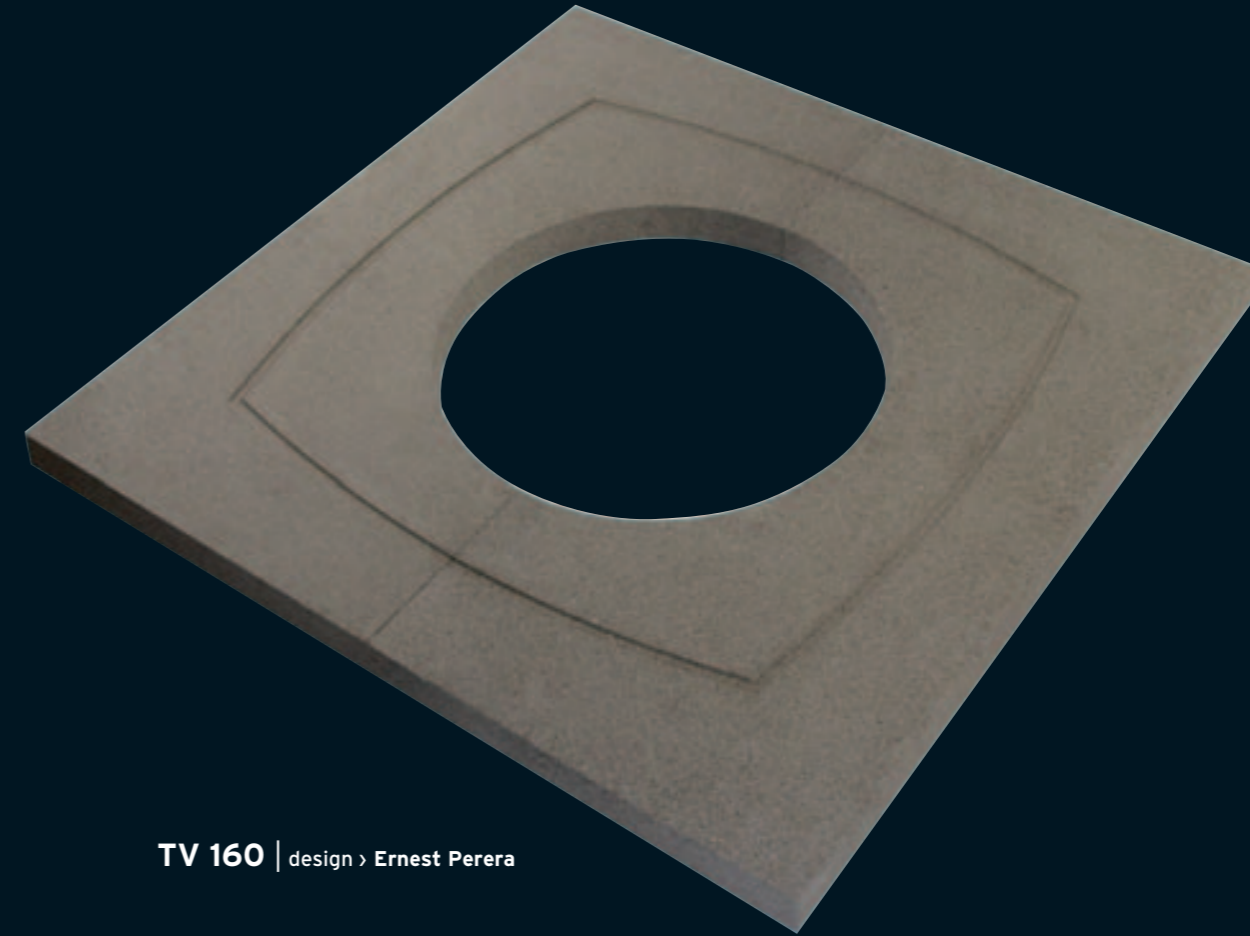
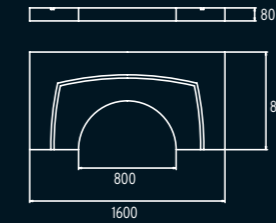

TV 160 | design > Ernest Perera

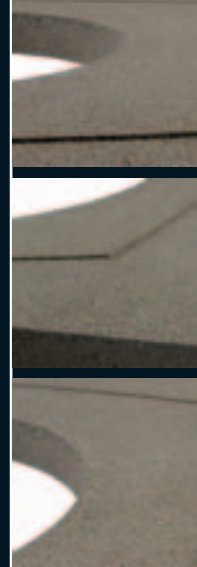

miscelânea | miscelânea | miscelânea | miscelânea | divers

cap i cua | design > Juan carlos Bolaños | 204 kg |

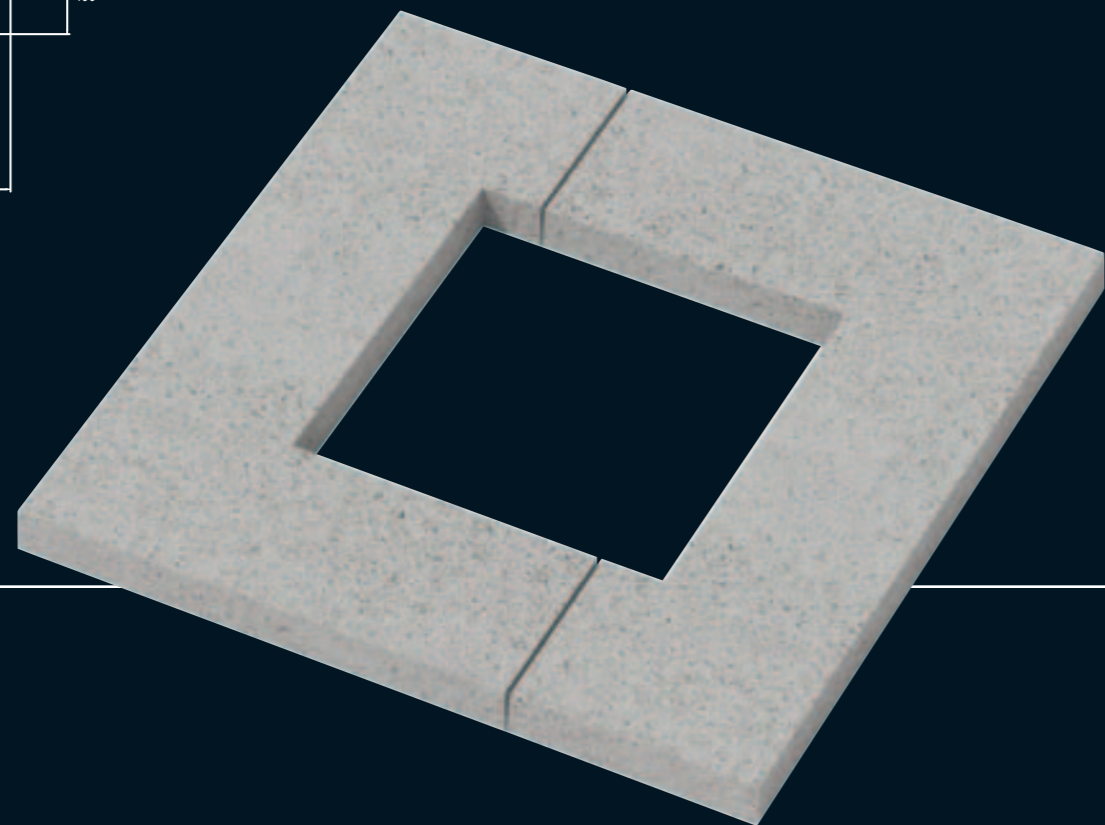
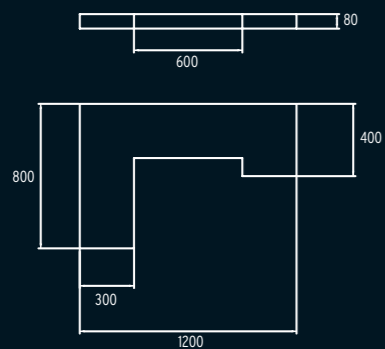

portic | design > Jordi Miralles | 600 kg |

mesa - taula - table

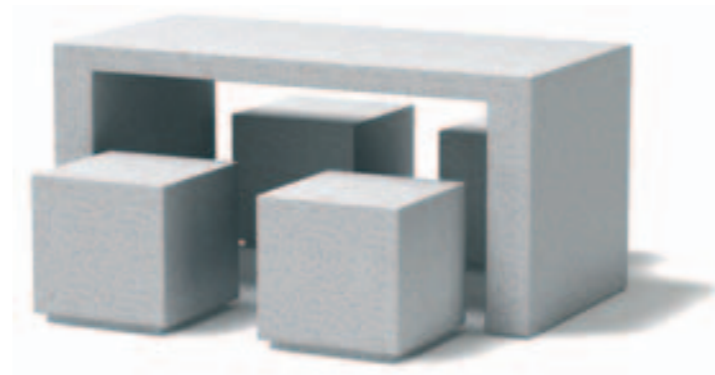

1 u. portic + (opcional - optional) 4 u. tetris Q

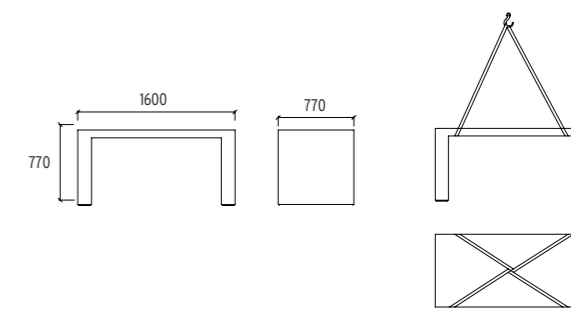

miscel·lània | miscel·lània | miscellaneous | divers

miscel·lània | miscel·lània | miscellaneous | divers



sunion | design › Ton Riera Ubía | 390 kg |

Papelera. Capacidad en litros: 75 l.

Paperera. Capacitat en litres: 75 l.

Waste paper bin. Capacity in litres: 75 l.

Corbeille à papier. Capacité en litres: 75 l.

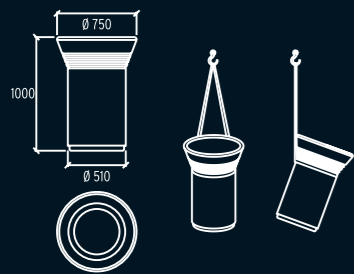

paros
design › Ton Riera Ubía | 195 kg |

Papelera. Capacidad en litros: 105 l.

Paperera. Capacitat en litres: 105 l.

Waste paper bin. Capacity in litres: 105 l.

Corbeille à papier. Capacité en litres: 105 l.

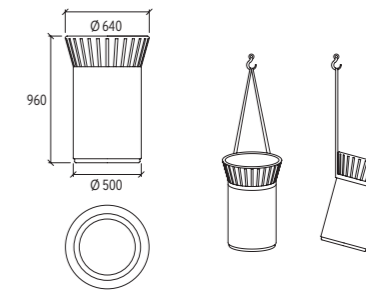

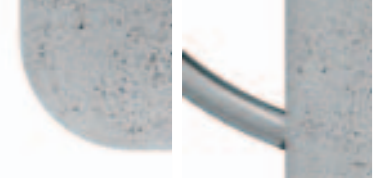

quad | design > Ernest Perera

quad bike | 54 kg |

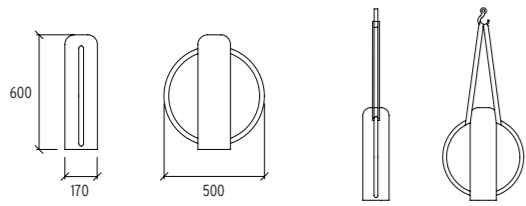

quad p | 118 kg |

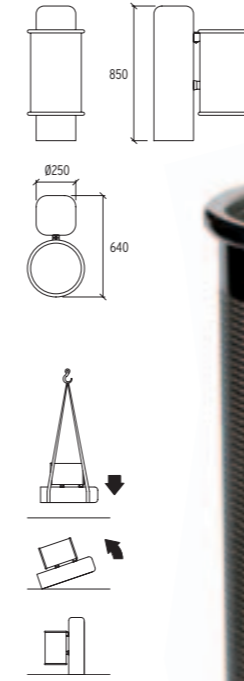

quad pt | 134 kg |

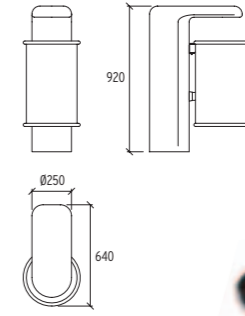

complementary elements

quad b pag. 39



quad pag. 63





versatil | design > I+D mago: urban | 300 kg |

papelera + cenicero
paperera + cendrer
litterbin + ashtray
poubelle + cendrier

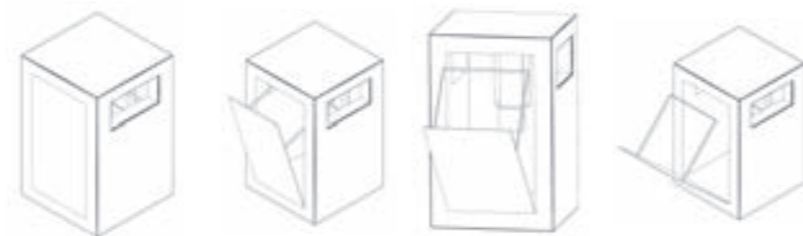
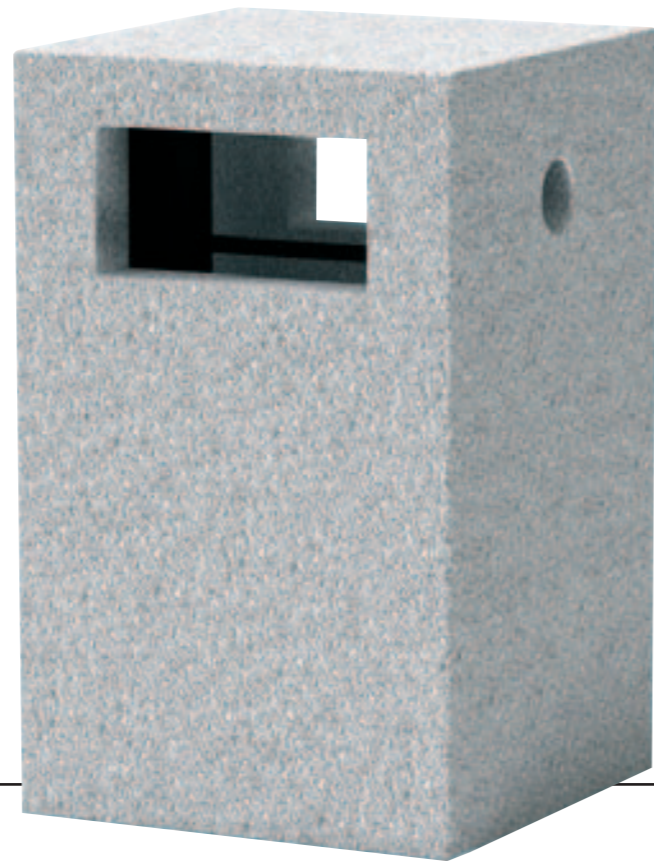
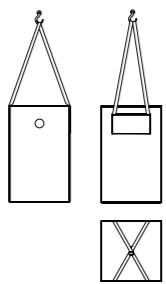
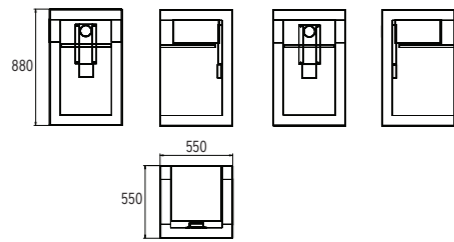

icon | design > Ernest Perera | 240 kg |

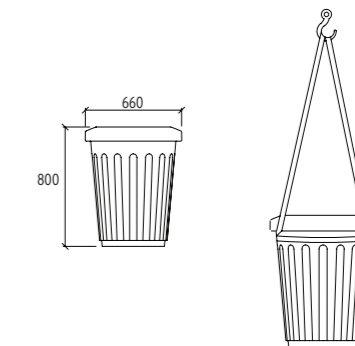

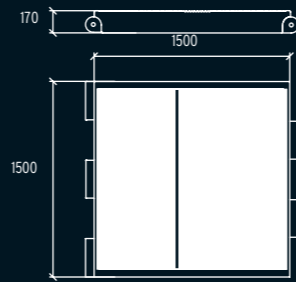

pass P | 796 kg |



pass R | 900 kg |



MÓDULOS PASARELA / MÒDULS PASSERA / GANGPLANK UNITS / MODULES PASSARELLE		
INICIO / INICI START / COMMENCEMENT	INTERMEDIO / INTERMEDI INTERMEDIATE / INTERMÈDE	FIN / FINAL END / FINALE
<p>PASS P</p>	<p>PASS R</p>	<p>PASS P</p>
<p>PASS C</p>	<p>PASS C</p> <p>UNION T UNIÓN UNION X</p>	<p>PASS C</p>

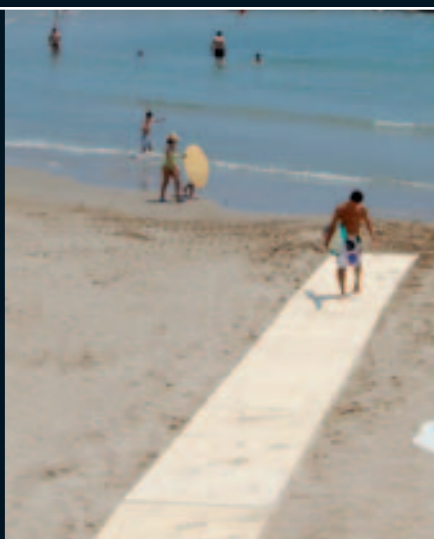

miscelànea | miscel·lània | miscellaneous | divers

miscelànea | miscel·lània | miscellaneous | divers



1



2



3



4



5

+vorera | design > Jordi Miró, Jordi Miralles

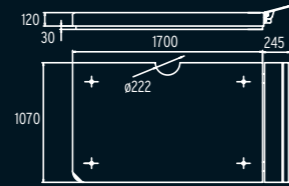
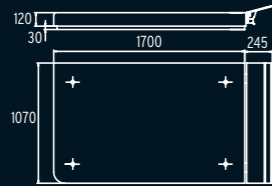

6

+vorera A | 745 kg

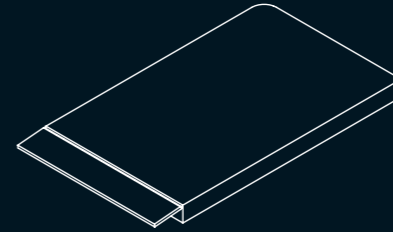

+vorera B | 745 kg

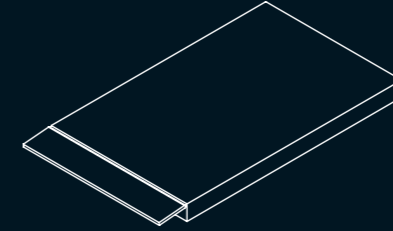

+vorera C | 745 kg

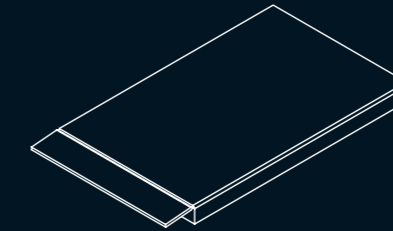

+vorera D | 685 kg

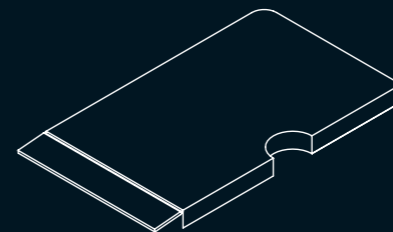

+vorera E | 685 kg

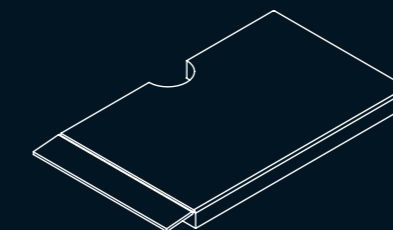

usos | usos | usage | usages

Andén Bus.
Andana Bus.
Bus Platform.
Quai Bus.

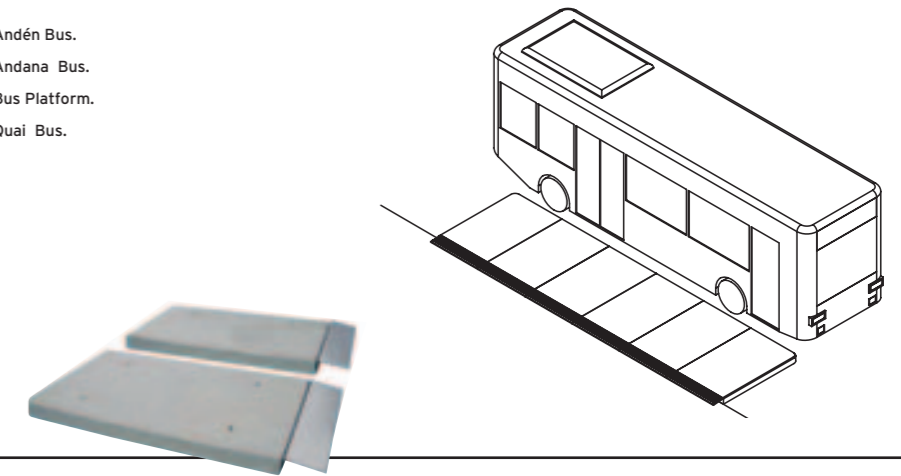

Ensanchador de acera.
Eixamplador de vorera.
Pavement extension.
Élargisseur de trottoir.

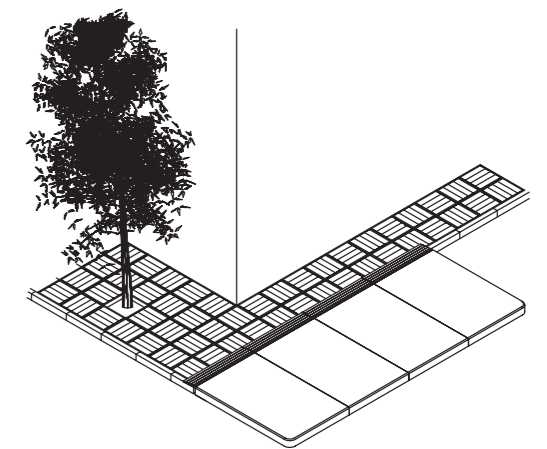
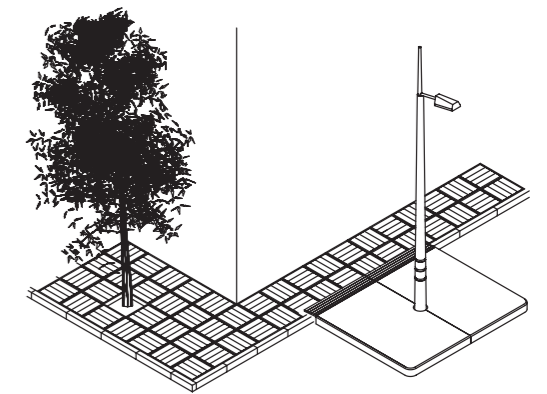

miscelània | miscelània | miscellaneous | divers

miscelània | miscelània | miscellaneous | divers

elementos y tratamientos opcionales

elements i tractaments opcionals

optional items and treatments

elements et traitements optionnels

mago URBAN

SISTEMA DE TRASLADO E INSTALACIÓN

Todos nuestros productos pueden ser equipados con argollas metálicas interiores o exteriores (extraíbles) para instalaciones de difícil acceso.

SISTEMA DE TRASLLAT I INSTAL·LACIÓ

Tots els nostres productes poden equipar-se amb argolles metàl·liques interiors o exteriors (extraïbles) per instal·lacions de difícil accés.

TRANSFER AND INSTALLATION SYSTEM

All our products may be fitted with interior or exterior metal shackles (removable) for installations with difficult access.

SYSTÈME DE DÉPLACEMENT ET D'INSTALLATION

Tous nos produits peuvent être équipés d'anneaux métalliques intérieurs ou extérieurs (extractibles) pour les installations à accès difficile.

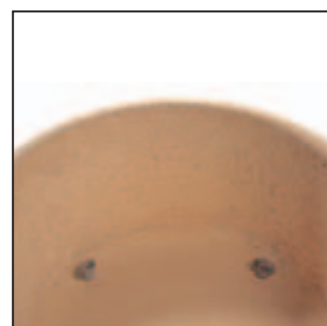

SISTEMA DE ANCLAJE

Opcional en todos los límites arquitectónicos y demás elementos, mediante varillas metálicas de 16 mm. Para otros tipos de anclaje, consultar. En el caso de anclar jardineras es imprescindible prever agujeros laterales de desagüe.

SISTEMA D'ANCORATGE

Opcional en tots els límits arquitectònics i altres elements, mitjançant varetes metàl·liques de 16 mm. Per a altres tipus d'ancoratge, consultar. En el cas d'ancorar jardineres és imprescindible preveure forats laterals de desguàs.

ANCHORAGE SYSTEM

Optional in all architectural limits and other items. Done by 16 mm metal bars. Consult for other anchorage types. In the event of jardiniere anchorage, side water drainage holes must be provided.

SYSTÈME D'ANCRAGE

Optionnel pour toutes les limites architectoniques et autres éléments, au moyen de chevilles métalliques de 16 mm. Pour d'autres types d'ancrage, consulter. Pour l'ancrage de jardinières, il est indispensable de prévoir des trous latéraux pour l'écoulement.



PERSONALIZACIÓN

Todos nuestros productos con una cara plana se pueden personalizar con un logo, bien en cerámica pintada a mano a todo color, bien en resina a un color y en relieve. Solicitenos presupuesto.

PERSONALITZACIÓ

Tots els nostres productes amb una cara plana es poden personalitzar amb un logotip, bé en ceràmica pintada a mà a tot color, bé en resina a un color i en relleu. Sol·liciti'ns pressupost.

CUSTOMISATION

All our products with a flat surface may be customized with a logo, either in full-colour hand-painted ceramics or in one colour resin in relief. Ask us for an estimate.

PERSONNALISATION

Tous nos produits à face plane peuvent être personnalisés par un logo, soit en céramique peinte à la main de toutes les couleurs, soit en résine d'une couleur et en relief. Demandez-nous un devis.

TRATAMIENTO ANTIGRAFFITI

Todos nuestros fabricados pueden suministrarse con tratamiento antigraffiti, consistente en una película superficial que facilita el posterior lavado de la pieza. Coste suplementario 5%.

TRACTAMENT ANTIGRAFFITI

Tots els nostres fabricats poden subministrar-se amb tractament antigraffiti, consistent en una pel·lícula superficial que facilita el posterior rentat de la peça. Cost suplementari 5%.

ANTI-GRAFFITI TREATMENT

All our manufactured products may be supplied with anti-graffiti treatment, comprising a surface film to enable subsequent washing of the item. Supplementary 5% cost.

TRAITEMENT ANTI-GRAFFITI

Tous nos produits peuvent être livrés avec un traitement anti-graffiti, consistant en une pellicule superficielle qui facilite le lavage postérieur de la pièce. Coût supplémentaire 5%.

características técnicas
 característiques tècniques
 technical features
 caractéristiques techniques

Archivos DXF / DWG disponibles en www.magogroup.com [mobiliario urbano]
 Arxius DXF / DWG disponibles a www.magogroup.com [mobiliari urbà]
 Documents DXF / DWG available on www.magogroup.com [urban items]
 Documents DXF / DWG disponibles sur www.magogroup.com [mobilier urbain]

COLORES DISPONIBLES Blanco (1) Ocre (2) Gris granito (3)	ACABADO Decapado.	MANTENIMIENTO Y CONSERVACIÓN El hormigón prefabricado apenas precisa mantenimiento. Para que se mantenga el aspecto original recomendamos tratar el producto, cuando presente síntomas de suciedad, con agua a presión.	DURABILIDAD Debido a la composición de nuestros productos la durabilidad de los mismos es ilimitada siempre y cuando se lleve a cabo un mantenimiento adecuado.
COLORS DISPONIBLES Blanc (1) Ocre (2) Gris granit (3)	ACABAT Decapat.	MANTENIMENT I CONSERVACIÓ El formigó prefabricat gairebé no necessita manteniment. Per a que es mantingui l'aspecte original recomanem tractar el producte, quan presenti símptomes de brutícia, amb aigua a pressió.	DURABILITAT Gràcies de la composició dels nostres productes, la durabilitat d'aquests és il·limitada sempre que es dugui a terme un manteniment adequat.
AVAILABLE COLORS White (1) Ochre (2) Grey granite (3)	FINISHED Scoured.	MAINTENANCE AND UPKEEP Prefabricated concrete hardly needs maintenance. To keep its original appearance we recommend treating the product, when it shows signs of dirt, with water at pressure.	DURABILITY Due to the composition of our manufactured products, their durability is unlimited provided that they are suitably maintained.
COULEURS DISPONIBLES Blanc (1) Ocre (2) Granite grise (3)	FINITION Décapage.	ENTRETIEN ET CONSERVATION Le béton préfabriqué nécessite peu d'entretien. Pour qu'il garde son aspect d'origine, nous recommandons d'entretenir le produit avec de l'eau sous pression dès l'apparition de saletés.	DURABILITÉ Étant donnée la composition de nos produits manufacturés, leur durabilité est illimitée s'ils sont entretenus de façon appropriée.



1



2

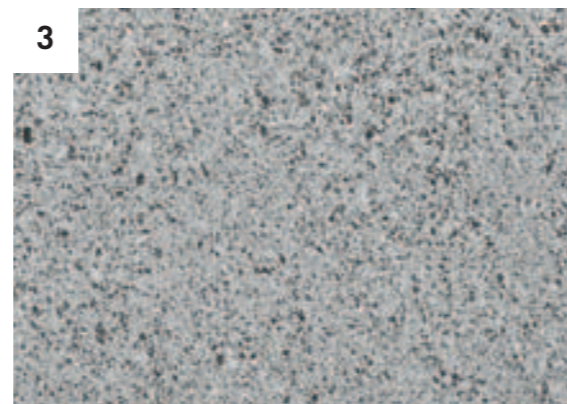

3



Petra

CONDICIONES DE VENTA:
 para obtener más información y detalles sobre nuestras condiciones de venta consulten nuestra web www.magogroup.com

CONDICIONS DE VENDA:
 per a obtenir més informació i detalls de les nostres condicions de venda consultin la nostra web www.magogroup.com

SALES TERMS:
 for further information about sales terms, please consult our web site www.magogroup.com

pour obtenir de plus amples informations sur nos conditions de ventes, veuillez consulter notre site Internet www.magogroup.com

Los pesos y dimensiones de nuestros fabricados son aproximados y en ningún caso contractuales.

Si precisa información complementaria sobre alguno de nuestros fabricados contacte con nuestro departamento comercial.

Manufacturas Mago S.L. se reserva el derecho de retirar / modificar sus fabricados sin previo aviso.

Els pesos i dimensions dels nostres fabricats són aproximats i en cap cas tenen valor contractual.

Si necessita informació complementària d'algun dels nostres productes contacti amb el nostre departament comercial.

Manufacturas Mago S.L. es reserva el dret de retirar / modificar els productes fabricats sense previ avis.

Weights and measures of our products are approximated and are not contractual under any circumstances.

If you require further information about any of our products, please contact the sales department.

Manufacturas Mago S.L. reserves the right to retire or to modify its manufactured products without notice.

Les poids et les dimensions de nos produits son approximatifs et en aucun cas contractuels.

Si vous souhaitez des précisions et informations complémentaires sur quelques-uns de nos produits, contactez notre service commercial.

Manufacturas Mago S.L. se réserve le droit de retirer / modifier ses produits finis sans avis préalable.

