

Design, Manufacture and  
Installation of  
**Laboratory & Hospital  
Furniture**



- ❖ Industrial
- ❖ Research
- ❖ Educational
- ❖ Medical

# FBS Contract Limited

## The Company

Since its formation in 1992, FBS Contracts Ltd has rapidly established itself as one of the leading manufacturers within the industry of specialist laboratory furniture. They have built up a broad customer base including many of the 'blue chip' Pharmaceutical Houses, NHS Hospitals, Universities and Schools.

FBS Contracts is one of a limited number of companies that employs its own installation teams to ensure high quality workmanship throughout the project. All Fitters hold current CSCS cards. We operate Autocad version 2006 and guarantee professional project management from design to installation. Staff are highly experienced, qualified and completely motivated towards the goal of 'total customer satisfaction'.

FBS are registered on Constructionline (no. 51682), Building Register (no. 0000211928) and are a CHAS registered contractor

Our sales team will be able to offer personal assistance in the design of your laboratory in accordance with your specific requirements and relevant HTM and British Standards.



**Tracey Newby**  
Managing Director



**Graham Heyes**  
Contracts Director

### Sales Team



**Graham Ellis**  
Area Sales Manager  
West



**Robert Albutt**  
Area Sales Manager  
East



**Chris Taylor**  
Sales Office  
Co-ordinator

### Project Team



**Trevor Phillips**  
Director /  
Project Manager



**Brian Ashall**  
Senior CAD  
Draughtsman



**Margaret Wilson**  
Estimator

# The Finished Laboratory

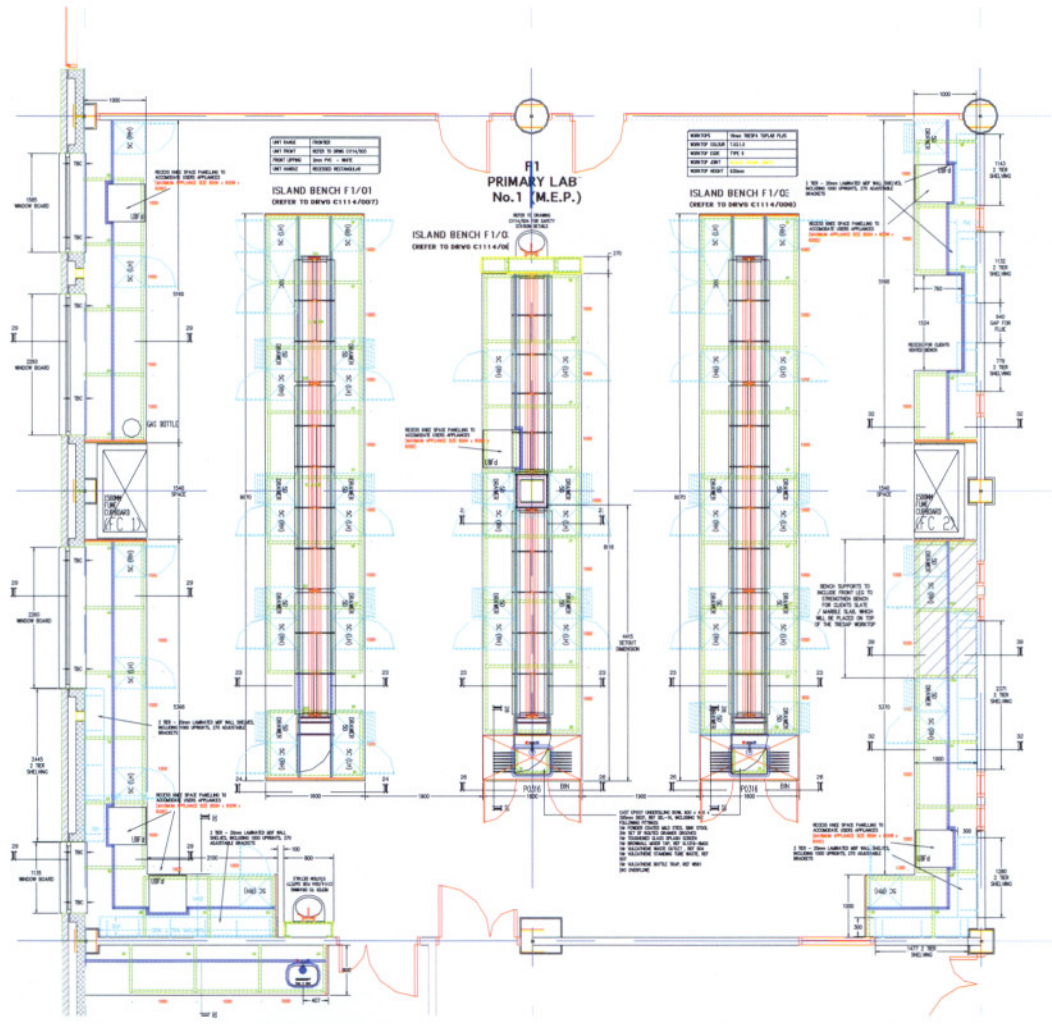

Typical examples of computer aided drawing with photograph of finished laboratory.



# FBS Worktop Specifications

## Worktop Materials

The choice of worktop material is critical to the overall performance of the working laboratory. The selection listed below offer different properties depending on the client requirements, detailed chemical resistant and property characteristics available upon request. Other materials such as solid wood, stainless steel and slate are also available.

### Solid Grade Laminate

#### Type 1 – General Laboratory Grade

A 16mm or 20mm thick sheet of solid impervious laminate suitable for most installations. This material has a high scratch and wear resistance, together with a good chemical resistance.

#### Type 2 – Toplab Plus

Available in 16mm and 20mm thick sheet, toplab is a cellulose fibre reinforced phenolic resin core with a pigmented decorative surface. Used when areas are exposed to the most demanding environments. This material resists a wide range of aggressive chemicals,

Data sheets are available upon request. Copies of these sheets are shown on the FBS Contracts CD.

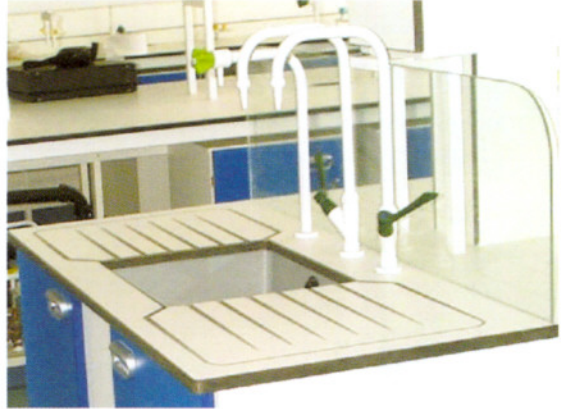

### Solid surfacing

A 40mm thick worktop suitable for Microbiological, Pathological, and Cleanroom environments. The worktop being formed from a 13mm thick non-porous, homogeneous surface, bonded to MDF baseboard. The joints in this material are seamless due to the methods of construction.

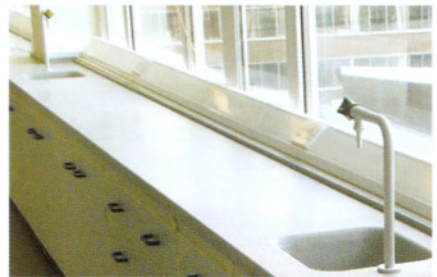

### Laminate

A 28mm thick worktop suitable for general laboratory applications. Formed by bonding a face laminate to a particle board core with a suitable balancer to the reverse. The front edge can either be post formed or PVC lipped, subject to colour.

FBS Contracts standard colour chart for laminate available upon request.



### Epoxy Resin

A 15mm thick monolithic material suitable for virtually all laboratory applications and environments. This material offers excellent acid, alkali and solvent resistance along with heat and shock resistance properties. Various lippings can be fitted to contain spillages, also a range of sinks available in the same material.

A colour chart is available upon request.



# System Specification

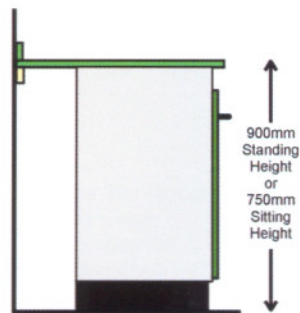

**Fixed Pedestal**  
Underbench units 500 deep

Benefits & Uses

- Most cost effective
- Sealable for containment
- Rigid structure

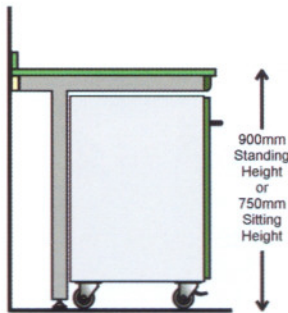

**Cantilever**  
Underbench units 500 deep

Benefits & Uses

- Suitable for moveable and mobile units
- Excellent for cleaning
- Flexibility in storage locations

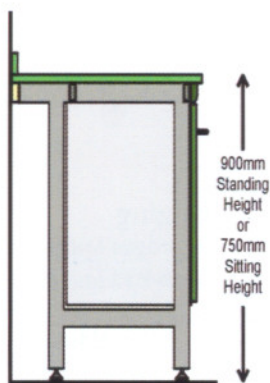

**'A' Frame**  
Underbench units 500 deep

Benefits & Uses

- Suitable for heavy loading
- Good floor access for cleaning
- Location of storage units are limited between 'A' frames

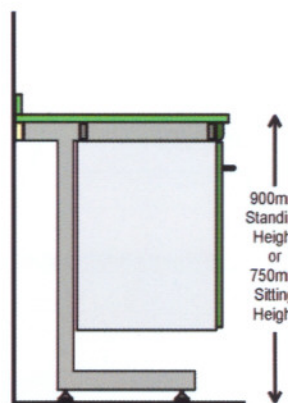

**'C' Frame**  
Underbench units 500 deep

Benefits & Uses

- Self supporting
- Ideal for suspended units
- Flexible storage locations

## Colours for Lippings



Electric Blue  
RAL 5002



Navy Blue  
RAL5003



Beech



Grey  
RAL7035



Green  
RAL6005

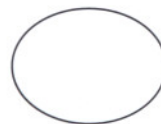

White  
RAL9010

## Selection of Stocked Handles



Satin Anodized Aluminum



Plastic 'D'  
Also in Stainless Steel



Metal Bow

**Please note**

Colours shown here are approximate only to RAL Standards due to printing limitations we do not accept any responsibility for variation.

# Standard Unit Specification



**Contour Range**  
Two Postformed Edges



**Frontier Range**  
Square Edges

**Drawerbox**

Blum Metabox epoxy coated combined runner & drawer sides. Bottom and back panel in 18mm MFC or MDF as per carcass

**Edging**

All edges lipped in 2mm PVC

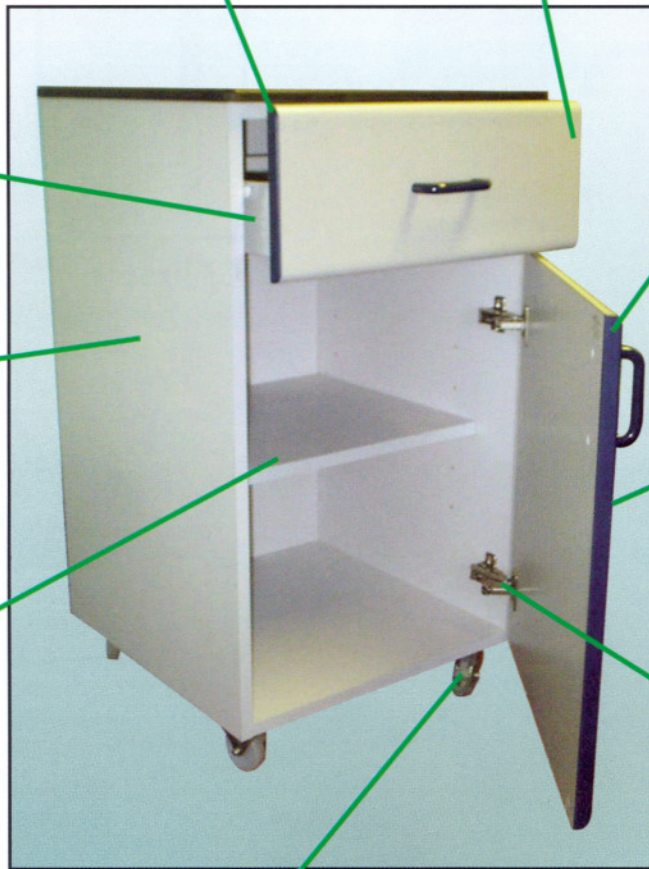

**Fronts**

High pressure laminate faced 18mm MDF or chipboard with balancer to match carcass colour

**Hinges**

Blum 170° concealed hinges

**Carcass**

Melamine faced 18 mm MDF or chipboard

**Shelf**

One adjustable shelf to match carcass material, lipped all round with 5 adjustable positions

**Mobile units** supplied with 2 braked and 2 unbraked castors.

**Fixed units** supplied on a black moisture resistant MDF plinth

**ALTERNATIVE SPECIFICATIONS TO BE DISCUSSED**

**Full written specifications available upon request**

# Reagent Shelving Specification

## Service Spine and Reagent Shelves

Single Tier Reagent Shelf  
300mm high  
1000mm wide  
300mm deep

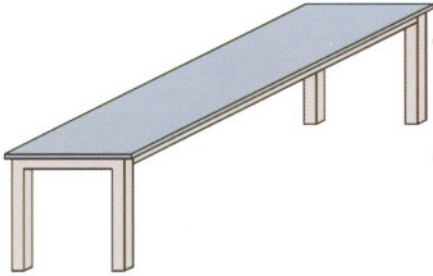

R501

Two Tier Reagent Shelf  
600mm high  
1000mm wide  
300mm deep

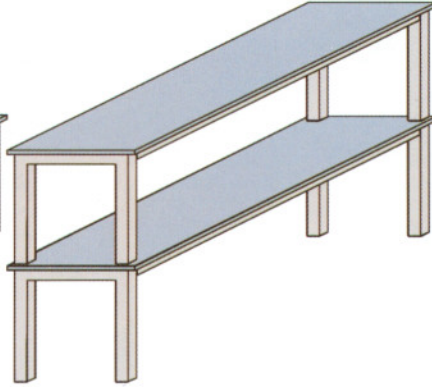

R511

Raised Service Shelf  
600mm high  
1000mm wide  
300mm deep

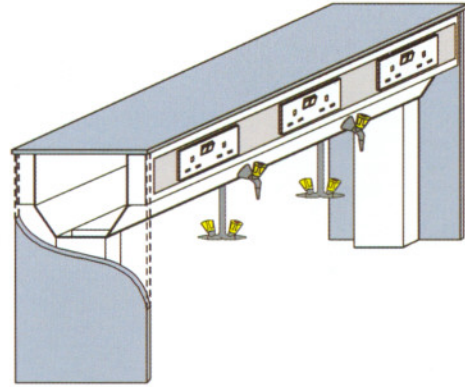

R521

Not to Scale

Shelving can be produced to suit client requirements, ranging from single to multi-tier, and either single sided or double sided, with or without services.

Shelving can be from a fixed design to a fully adjustable system giving greater flexibility.



Reagent shelving can incorporate several tiers of shelving together with mechanical and electrical services.

Services can be fed from either below the bench or from overhead by means of service columns.

All mechanical services are suspended from the underside of the service spine, electrical services are mounted in a fixed trunking system. The style of trunking should be considered depending on the electrical installation, ie data sockets, telephone outlets, and visual display connections.

# FBS Specifications

## Sinks and Drip Cups

### Stainless Steel Sinks

Manufactured from 316 grade stainless steel which offers excellent acid and chemical resistance.

Each bowl is pierced to accept a 38mm waste outlet with an 85mm flange. Sink and drainers are punched for 2No tap holes at 180 centres. Sink bowls can be supplied either self rimming or flat flange. Please advise if an overflow hole is required for a plug and chain assembly or no hole for a stand up tube.

<b>Self Rimming Bowls</b>	305 x 356 x 160d	ref : IOMOS12SR
	508 x 356 x 180d	ref : IOMOS27SR
	508 x 356 x 250d	ref : IOMOS210SR
	533 x 381 x 200d	ref : IOMOS38SR
	533 x 381 x 250d	ref : IOMOS3810SR
	610 x 457 x 305d	ref : IOMOS412SR

<b>Flat Flange Bowls</b>	305 x 356 x 160d	ref : IOMOS12FF
	508 x 356 x 180d	ref : IOMOS27FF
	508 x 356 x 250d	ref : IOMOS210FF
	533 x 381 x 200d	ref : IOMOS38FF
	533 x 381 x 250d	ref : IOMOS3810FF
	610 x 457 x 305d	ref : IOMOS412FF

<b>Inset Sinks</b>	<b>single bowl, single drainer</b>	
	<b>Bowl size</b>	
	965 x 525 (432x356x180)	ref LI0952SL/SR
	1028 x 500 (508x356x255)	ref LI1050SL/SR
	<b>single bowl, double drainer</b>	
	<b>Bowl size</b>	
1376 x 525 (432x356x180)	ref LI1352SD	
1448 X 525 (508x356x255)	ref LI1452SD	

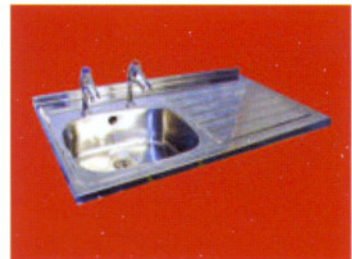

### Cast Epoxy Resin Sinks

Cast epoxy resin is a very hard and durable material with excellent chemical and stain resistance, suitable for most environments. Available in a variety of colours, depending upon delivery requirements



#### Drop on sink bowls

255 x 110 x 150d	ref SGS2-DO
300 x 200 x 200d	ref SDS5-DO
350 x 300 x 200d	ref SS6-DO
450 x 365 x 220d	ref SM8-DO
400 x 400 x 300d	ref SGL10-DO

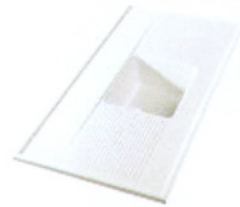

#### Overhang Sink Bowls

<b>Moulded Single Drainer with sink bowl of 400 x 400 x 305d</b>	500 x 400 x 290d	ref SGR11
	600 x 450 x 300d	ref SPL16

#### Moulded Double Drainer with central sink bowl.

Single Ribbed drainer, Sink position left or right handed.

L x D	Bowl size	ref
1350 x 760,	600 x 450 x 250d,	DD1350
1500 x 750,	450 x 360 x 200d,	DD1500
1540 x 640,	450 x 365 x 200d,	DD1540
1650 x 780,	600 x 450 x 250d,	DD1650
1700 x 750,	625 x 370 x 270,	DD1700

Worktops available in a standard depth of 600 to 850.

900 wide top	ref SD900
1000wide top	ref SD1000
1200wide top	ref SD1200
1400wide top	ref SD1400
1500wide top	ref SD1500



Detailed drawings on request

# FBS Specifications

## Sinks and Drip Cups

### White Fireclay Sinks

Suitable for general use with various acids and solvents.  
Sink bowls are supplied for mounting on the under side of work surfaces only.

#### Belfast Sinks

460 x 380 x 210d  
610 x 460 x 260d  
760 x 460 x 260d

58

#### Larch Sinks (No overflow hole)

355 x 280 x 150d  
330 x 330 x 180d  
455 x 355 x 190d  
5 x 380 x 230d



### Polypropylene Sinks and Drip Cups

Sinks are manufactured from Black Polypropylene which offers excellent acid and chemical resistance. Each bowl is pierced to accept a 38mm waste outlet with an 76mm flange. Sink bowls are supplied for mounting on the under side of work surfaces. Please advise if an overflow hole is required for a plug and chain assembly or no hole for a stand up tube.

492 x 241 x 171d,  
552 x 400 x 231d,  
343 x 288 x 140d,  
445 x 343 x 140d,  
492 x 419 x 165d,

ref 601  
ref 602  
ref 604/1  
ref 604/2  
ref 604/4



### Drip Cups



Small Circular Drip Cups

102 diameter



Large Circular Drip Cups

168 diameter



Small Oval Drip Cups

175 x 102



Large Oval Drip Cups

264 x 111

### Waste Fittings



Wastes

ref 504



Standing Waste Tubes

ref 507



Plug & Chain Assembly

ref 508



Overflow Assemblies

ref 509



Anti-Siphon Bottle Traps

ref 561



# FBS Tap Specifications

## Service Fittings and Showers

FBS Contracts Limited offer taps and showers from all the laboratory tap manufacturers, examples of which are shown below. For further information please contact our sales department.



Water taps available in range of fittings types and fittings, from single water taps to multi headed taps, bench mounted to wall mounted, hot and cold mixers. Mixers are available with lever handles and standard handles, also the outlet nozzles can be changed from serrated to anti-splash. Please advise on your needs at time of enquiry. It should be noted that water taps that connect direct to the mains cannot have a serrated type nozzle without the use of an air break, due to water bye laws.

Special taps are available for demineralised water.



Gas taps again are available in a range of fittings, from single to multi head, bench mounted to wall and pendant type. Please advise on type of gas the outlet is to be used for, i.e. natural gas, nitrogen, oxygen etc, since this effects the type of outlet to be used.

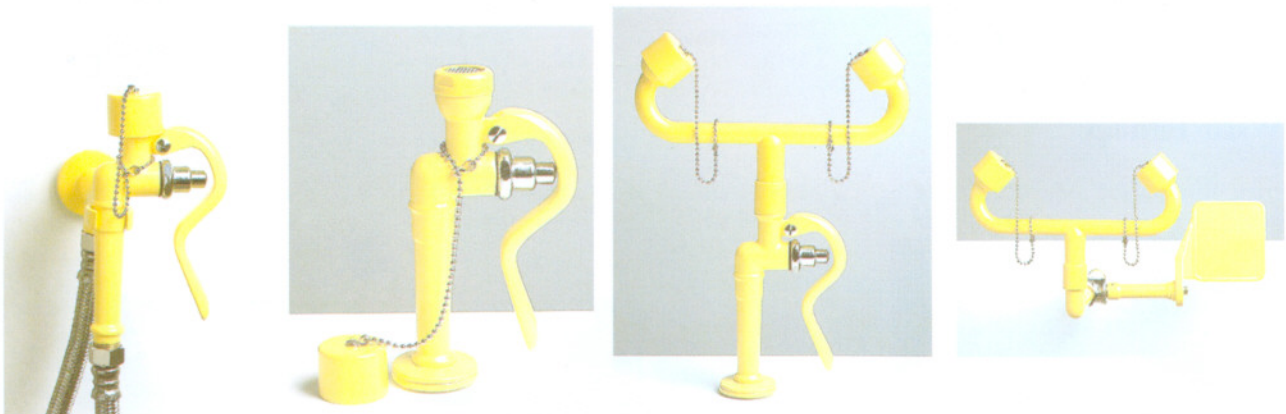

Emergency eye wash showers for bench mounting or panel mounting are available, together with a range of full drench showers.

# FBS Product Range

## Fume Cupboards

In order to satisfy the growing safety at work and fume cupboard standards requirements, FBS Contracts Limited offer a range of continuously monitoring control / alarm, which visually and audibly display the status of your unit. A full range of functions are available, including remote fan on/off, airflow failure and sash high indication, plus additional features such as washer system and replacement air operation, should they be required. All panels comply with BS7258 and COSHH requirements.

The bench mounted fume cupboard shown is available with a standard working height of 900mm and the cabinets are available in the following widths, 1000, 1200, 1500, 1800 and 2000. Special versions available upon request.



## Custom Built Fume Cupboards Available upon Request



### Specification

- External sides : White epoxy coated steel
- Internal : Solid grade laminate
- Working Level : Cast epoxy resin
- Aerofoil : 316 grade stainless steel
- Support Frame : White epoxy coated steel
- Sash : 6mm Toughened glass counterbalanced with failsafe pulley and weight system.
- Storage : optional
- Mechanical and Electrical services to suit individual needs.



# FBS Product Range



## *From Concept Drawings to Reality*



3D Modelling  
helps you  
visualise your  
laboratory



*(this facility is subject to timescale of project)*

# FBS Product Range

## Reception Counters and Nurses Stations

Reception Counter with glazed panels for an Accident and Emergency Department



## General Reception Counters and Nurses' Stations



# FBS Product Range

## Safety Stations



Combining a series of panels and services to provide a 'station' to meet clients' individual requirements

Stations can provide simple handwashing facilities or emergency eyewash facilities in case of an accident







## FBS Product Range

As we manufacture all our own furniture, we are able to offer bespoke items to suit your individual applications and requirements. Samples of education furniture items are:



**Mobile Tables**



**Equipment Trolleys**



**Storage Trolleys**



**Mobile book/tray trolleys**



**Service Bollards**



**Octagons**



**Loose Tables**



**Computer Benching**



**Music Benching**



**Food Technology Tables**



**Height Adjustable Tables**

## Comments from those who have worked with FBS Contracts Limited

### Laing O'Rourke Ltd

'I found the company's personnel to be extremely professional in their approach to the contract. They submitted high quality, detailed drawings and managed the project well throughout.'

### Wates Construction

'The work carried out was completed to a very high standard and FBS proved to be extremely co-operative through the design stage as well as installation stage. We would highly recommend FBS to any other Contractor wishing to use them on a similar laboratory fit out.'

### Kier Build

'From tender to completion FBS adopted a flexible pro-active approach to the project which was completed on time within budget. We look forward to working again with FBS Contracts in the future, and strongly recommend their services.'

### Bovis Lend Lease Pharmaceuticals

'They have performed to a high standard on all projects they have been engaged on, in terms of both the quality of workmanship and overall programme.'

### Phoenix Contractors Ltd

'We have found the standard of workmanship both in manufacture and site fixing to be of the highest quality, borne out by the fact that little or no snagging has been required on the completed phases.'

### Norwest Holst

'I feel it would be an opportune moment to thank FBS for the co-operation and pro-active approach they have shown during the course of the project. All have certainly made our task easier and enjoyable and we look forward to working with you on the next phase if possible.'

### Bullock

'May I also thank you, your company and your employees on site for the 100% effort and co-operation you gave me throughout the project. It was a great tribute to the lads on site to see them all work together in such trying conditions.'

## Clients Include

### Industrial

GlaxoSmithKline  
Xenova  
Astra Zeneca  
Eli Lilly - Widnes/Basingstoke  
MAFF - Weybridge/Thirsk  
British Biotech Pharmaceuticals  
Quintiles  
Boots Company  
Laporte Industries  
The Welding Institute (TWI)  
Urneco  
AWE Aldermaston

### Educational

Manchester Metro University  
Imperial College London  
University of Leeds  
University of Liverpool  
Cambridge University  
Liverpool School Tropical Medicine  
London School of Pharmacy  
Salford University  
Leicester University  
Plymouth University  
Nottingham University  
Manchester University

### Medical

Southampton General Hospital  
Halifax Hospital  
Christie Hospital  
John Radcliffe Hospital, Oxford  
Northern General Hospital  
Glan Clwyd Hospital  
Halton Hospital, Runcorn  
Inst. of Ophthalmology, London  
Royal Devon & Exeter Hospital  
BUPA Manchester  
Bodmin Secure Hospital  
Oldham General



# FBS Product Range



**Reagent Shelving**



**Reception Counters**

**Laminated Panels**

**Transfer Hatches**



**Fume Cupboards**

**Step Over Benches**



**Boot Racks**

**Clean Room Panels**

**Wash Hand Stations**



**Post Formed Vanity Units**

**Toilet Cubicles**

**Lockers**

**Shelving**

**Eye Wash Stations**



**Hospital Furniture to HTM63**



**FBS Contracts Limited**

41 Arkwright Road, Astmoor Industrial Estate, Runcorn, Cheshire, WA7 1NU

Tel No 01928 591606 Fax No 01928 573663

Email : [Sales@fbscontracts.co.uk](mailto:Sales@fbscontracts.co.uk) Web : [www.fbscontracts.co.uk](http://www.fbscontracts.co.uk)