

Form A (60°)
Code 114: BS, HSS M2
Code 115: ASA, HSS M2

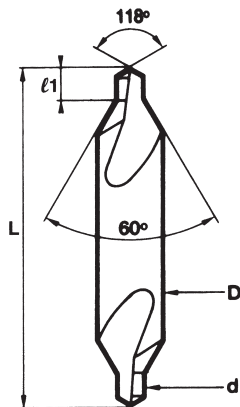

BS	ASA	D x d mm (")	L	l1	Price £
	000	3.17 x 0.51 (1/8 x .020)	31	0.6 - 0.8	4.00
	00	3.17 x 0.63 (1/8 x .025)	31	0.8 - 1.0	3.45
	0	3.17 x 0.79 (1/8 x 1/32)	31	1.1 - 1.3	3.15
1	1	3.17 x 1.19 (1/8 x 3/64)	31	1.5 - 1.7	2.00
2		4.76 x 1.58 (3/16 x 1/16)	47	2.0 - 2.4	2.30
	2	4.76 x 1.98 (3/16 x 5/64)	47	2.5 - 2.9	2.30
3		6.35 x 2.38 (1/4 x 3/32)	50	2.9 - 3.4	2.70
	3	6.35 x 2.77 (1/4 x 7/64)	50	3.5 - 4.0	2.70
4	4	7.93 x 3.17 (5/16 x 1/8)	54	3.9 - 4.4	3.50
5	5	11.11 x 4.76 (7/16 x 3/16)	70	6.1 - 6.6	5.85
	6	12.70 x 5.55 (1/2 x 7/32)	76	7.2 - 7.8	7.00
6	7	15.87 x 6.35 (5/8 x 1/4)	82	8.0 - 8.6	13.10
7	8	19.05 x 7.93 (3/4 x 5/16)	89	10.1 - 10.8	20.10
	9	22.22 x 8.73 (7/8 x 11/32)	92	11.2 - 11.9	36.10
	10	25.40 x 9.52 (1 x 3/8)	95	12.2 - 12.9	40.10

Reamers

Centre Drills & Spotting Drills

Countersinks & Counterbores

Slot Drills & End Mills

Taps & Dies

TUSA
Carbide Tooling

Form A (60°)

Code 011: HSS M2

Code 010: HSS M35 (5%) Cob

Code 105: HSS M42 (8%) Cob

Code 811: HSS M35 (5%) Cob TiN coated

Code 910: HSS M42 (8%) Cob TiCN coated

Code 8100: Carbide K15 micrograin

D x d	L	ℓ1	M2 Price £	M35 Price £	M42 Price £	TiN Price £	TiCN Price £	CBD Price £
3.15 x 0.5*	25	0.6 - 0.8	2.20	-	-	8.65	-	30.75
3.15 x 0.63*	25	0.7 - 0.9	2.20	-	-	-	-	-
3.15 x 0.8*	25	1.0 - 1.2	2.20	-	-	8.65	-	30.75
3.15 x 1.0	31	1.3 - 1.6	2.20	5.10	8.35	8.65	16.10	33.25
3.15 x 1.25	31	1.6 - 1.9	2.40	5.10	8.35	8.65	16.10	33.25
3.5 x 0.75	35	1.0 - 1.2	-	5.55	-	-	-	-
4.0 x 1.0	35	1.3 - 1.6	-	5.15	-	8.75	-	33.25
4.0 x 1.6	35	2.0 - 2.4	2.25	5.15	8.40	8.75	16.20	33.25
5.0 x 1.5	40	2.0 - 2.4	-	5.65	-	9.25	-	40.65
5.0 x 2.0	40	2.5 - 2.9	2.40	5.65	8.80	9.25	16.70	40.65
6.0 x 2.0	45	2.5 - 2.9	-	6.45	-	10.55	-	48.50
6.3 x 2.5	45	3.1 - 3.6	2.70	6.45	10.45	10.55	18.35	48.50
8.0 x 2.5	50	3.1 - 3.6	-	7.40	-	11.95	-	59.30
8.0 x 3.0	50	3.9 - 4.4	-	7.40	-	11.95	-	59.30
8.0 x 3.15	50	3.9 - 4.4	3.40	7.40	11.95	11.95	22.30	59.30
10.0 x 3.0	55	3.9 - 4.4	-	9.35	-	15.75	-	78.20
10.0 x 4.0	55	5.0 - 5.6	4.40	9.35	15.65	15.75	28.35	78.20
12.0 x 4.0	63	5.0 - 5.6	-	15.30	-	26.85	-	-
12.0 x 5.0	63	6.3 - 6.9	-	15.30	-	26.85	-	127.60
12.5 x 5.0	63	6.3 - 6.9	6.60	15.30	25.95	26.85	45.90	127.60
14.0 x 5.0	69	6.3 - 7.2	13.20	-	-	-	-	-
16.0 x 6.3	71	8.0 - 8.6	13.05	20.60	-	38.55	-	198.65
20.0 x 8.0	80	10.1 - 10.8	20.10	-	-	71.90	-	-
25.0 x 10.0	100	12.8 - 13.5	39.30	-	-	-	-	-
31.5 x 12.5	125	15.5 - 16.5	100.30	-	-	-	-	-

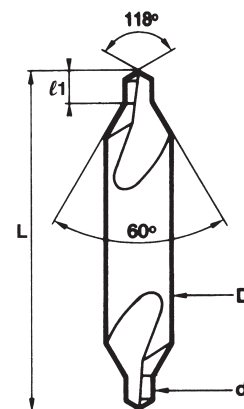

* Single end

Form A (60°)
Code 185: HSS M2

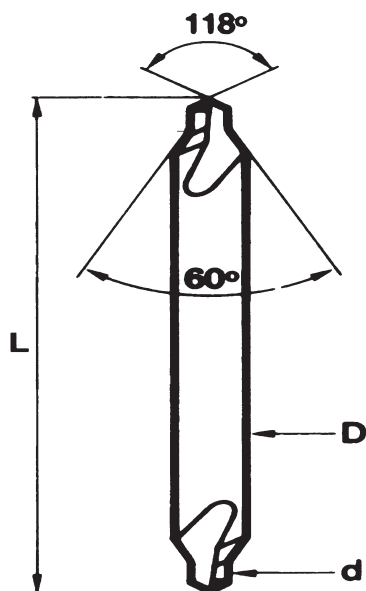

A S A	D x d mm (")	L	Price £
1 x 3		76	6.70
1 x 4	3.17 x 1.19	102	11.15
1 x 5	(1/8 x 3/64)	127	16.90
1 x 6		152	18.75
2 x 3		76	7.00
2 x 4	4.76 x 1.98	102	10.80
2 x 5	(3/16 x 5/64)	127	16.05
2 x 6		152	17.85
3 x 3		76	7.00
3 x 4	6.35 x 2.77	102	10.80
3 x 5	(1/4 x 7/64)	127	16.05
3 x 6		152	17.85
4 x 3		76	7.20
4 x 4	7.93 x 3.17	100	10.80
4 x 5	(5/16 x 1/8)	125	18.45
4 x 6		150	20.10
4.5 x 4	9.52 x 3.57	100	11.20
4.5 x 5	(3/8 x 9/64)	125	21.25
4.5 x 6		150	22.85
5 x 4	11.11 x 4.76	100	14.40
5 x 5	(7/16 x 9/64)	125	25.25
5 x 6		150	27.65
6 x 4	12.70 x 5.55	100	15.65
6 x 5	(1/2 x 7/32)	125	25.25
6 x 6		150	27.65
7 x 5	15.87 x 6.35	125	30.05
7 x 6	(5/8 x 6.35)	150	35.70
8 x 6	19.05 x 7.93	150	41.75
	(3/4 x 5/16)		-

Reamers

Centre Drills & Spotting Drills

Countersinks & Counterbores

Slot Drills & End Mills

Taps & Dies

TUSA
Carbide Tooling

Form A (60°)

Code 018: HSS M2

D x d	L	ℓ1	Price £
3.5 x 0.75	60	1.0 - 1.2	7.65
4.0 x 1.0	60	1.3 - 1.6	7.60
5.0 x 1.5	60	2.0 - 2.4	7.40
6.0 x 2.0	80	2.5 - 2.9	7.95
8.0 x 2.5	80	3.1 - 3.6	9.95
8.0 x 3.0	80	3.9 - 4.4	9.95
4.0 x 1.0	100	1.3 - 1.6	13.40
5.0 x 1.5	100	2.0 - 2.4	13.15
6.0 x 2.0	100	2.5 - 2.9	13.15
8.0 x 2.5	100	3.1 - 3.6	13.15
8.0 x 3.0	100	3.9 - 4.4	13.15
10.0 x 3.0	100	3.9 - 4.4	13.15
10.0 x 4.0	100	5.0 - 5.6	13.15
12.0 x 4.0	100	5.0 - 5.6	17.40
12.0 x 5.0	100	6.3 - 6.9	17.40
3.5 x 0.75	120	1.0 - 1.2	24.90
4.0 x 1.0	120	1.3 - 1.6	17.85
5.0 x 1.5	120	2.0 - 2.4	17.55
5.0 x 1.6	120	2.0 - 2.6	17.55
6.0 x 2.0	120	2.5 - 2.9	17.55
8.0 x 2.5	120	3.1 - 3.6	20.15
8.0 x 3.0	120	3.9 - 4.4	20.15
10.0 x 3.0	120	3.9 - 4.4	23.35
10.0 x 3.15	120	3.9 - 4.6	23.35
10.0 x 4.0	120	5.0 - 5.6	23.35
12.0 x 4.0	120	5.0 - 5.6	28.55
14.0 x 5.0	120	6.3 - 6.9	35.05
4.0 x 1.0	150	1.3 - 1.6	21.45
5.0 x 1.5	150	2.0 - 2.4	21.20
6.0 x 2.0	150	2.5 - 2.9	21.20
8.0 x 2.5	150	3.1 - 3.6	24.00
8.0 x 3.0	150	3.9 - 4.4	24.00
10.0 x 3.0	150	3.9 - 4.4	27.70
10.0 x 4.0	150	5.0 - 5.6	27.70
12.0 x 4.0	150	5.0 - 5.6	33.55
16.0 x 6.3	150	8.0 - 8.9	49.80
5.0 x 2.0	200	2.5 - 2.9	44.60
6.3 x 2.5	200	3.1 - 3.6	43.75
8.0 x 3.15	200	3.9 - 4.4	41.35
10.0 x 4.0	200	5.0 - 5.6	45.05

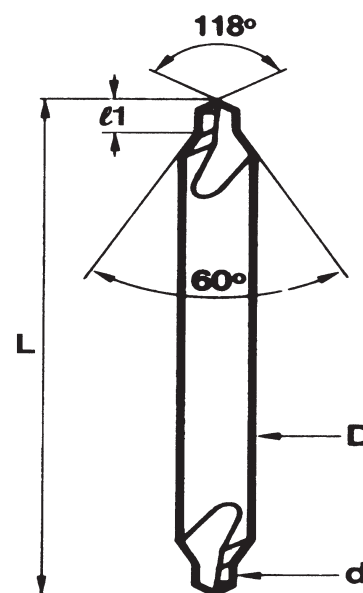

Form B (Bell type 60°/120°)

Code 135: HSS M2

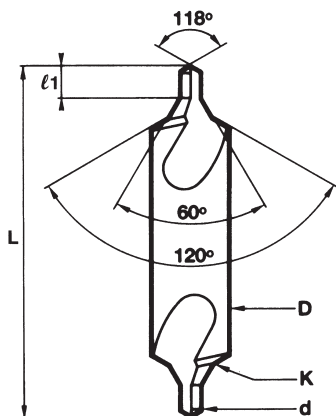

ASA	D x d	L	K	l1	Price £
11	3.17 x 1.19	31	2.5	1.5 - 1.7	2.85
12	4.76 x 1.58	47	3.8	2.0 - 2.4	3.10
13	6.35 x 2.38	50	5.1	2.9 - 3.4	3.75
14	7.93 x 2.77	54	6.3	3.1 - 3.6	4.85
15	11.11 x 3.96	70	8.9	5.0 - 5.6	7.90
16	12.70 x 4.76	76	10.1	6.1 - 6.6	9.40
17	15.87 x 5.55	82	12.7	7.1 - 7.7	16.85
18	19.05 x 6.35	89	15.2	8.0 - 8.6	24.85
19	22.22 x 7.93	92	17.8	11.2 - 11.9	44.10
20	25.4 x 9.52	95	20.3	12.2 - 12.9	52.15

Code 134: HSS M2

BS	D x d	L	K	l1	Price £
1-B	3.17 x 1.19	38	1.9	1.6 - 2.0	7.10
2-B	4.76 x 1.58	45	2.8	2.0 - 2.4	7.10
3-B	6.35 x 2.38	50	3.8	3.3 - 3.9	7.10
4-B	7.93 x 2.77	56	4.8	4.1 - 4.7	8.10
5-B	11.11 x 3.96	64	6.6	5.7 - 6.3	13.65
6-B	15.87 x 5.55	76	9.5	7.7 - 8.3	22.05
7-B	19.05 x 6.35	88	11.4	9.2 - 10.0	39.40

**Centre Drills
DIN 333-R**

Form R (Radius point)

Code 012: HSS M2

Code 8112: Carbide K15 micrograin

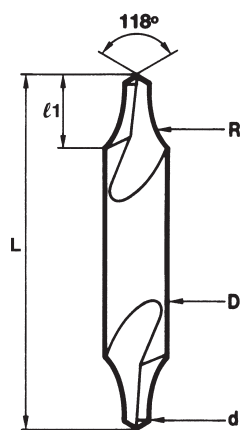

D x d	L	l1	R	HSS Price £	CBD Price £
3.15 x 0.5*	25	0.6 - 0.8	2	3.65	41.55
3.15 x 0.8*	25	1.0 - 1.2	2.5	3.65	-
3.15 x 1.0	31	1.3 - 1.6	2.9	3.65	43.10
3.15 x 1.25	31	1.6 - 1.9	3.15	3.65	43.10
4.0 x 1.6	35	2.0 - 2.4	4	3.70	43.10
5.0 x 2.0	40	2.5 - 2.9	5	3.95	53.45
6.3 x 2.5	45	3.1 - 3.6	6.3	4.75	63.80
8.0 x 3.15	50	3.9 - 4.4	8	5.20	75.50
10.0 x 4.0	55	5.0 - 5.6	10	6.60	100.65
12.5 x 5.0	63	12.5 - 13.1	12.5	11.35	-

* Single end

Reamers

Centre Drills & Spotting Drills

Countersinks & Counterbores

Slot Drills
End Mills

Taps
Dies

TUSA
Carbide Tooling

Code 014: Form W (Reinforced point)
HSS M2

D x d	L	ℓ1	Price £
3.15 x 0.5*	25	0.6 - 0.8	3.85
3.15 x 0.8*	25	1.0 - 1.2	3.85
3.15 x 1.0	31	1.3 - 1.6	3.85
3.15 x 1.25	31	1.6 - 1.9	3.85
4.0 x 1.6	35	2.0 - 2.4	4.10
5.0 x 2.0	40	2.5 - 2.9	4.50
6.3 x 2.5	45	3.1 - 3.6	4.95
8.0 x 3.15	50	3.9 - 4.4	5.50
10.0 x 4.0	55	5.0 - 5.6	7.10

* Single end

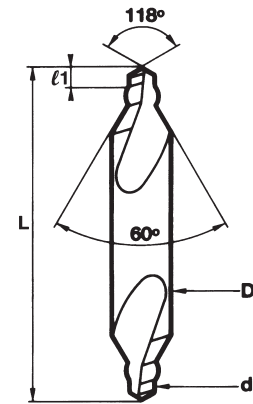
Centre Drills 90°
Code 015: HSS M2

D x d	L	ℓ1	Price £
3.5 x 0.75	35	1.0 - 1.2	8.80
4.0 x 1.0	35	1.3 - 1.6	8.15
5.0 x 1.5	40	2.0 - 2.4	8.35
6.0 x 2.0	15	2.5 - 2.9	10.10
8.0 x 2.5	50	3.1 - 3.6	11.65
8.0 x 3.0	50	3.9 - 4.4	11.65
10.0 x 3.0	55	3.9 - 4.4	15.30
10.0 x 4.0	55	5.0 - 5.6	15.30
12.0 x 4.0	63	5.0 - 5.6	22.95
12.0 x 5.0	63	6.3 - 6.9	22.95
14.0 x 5.0	71	6.3 - 6.9	32.25
18.0 x 6.0	80	8.0 - 8.6	46.75

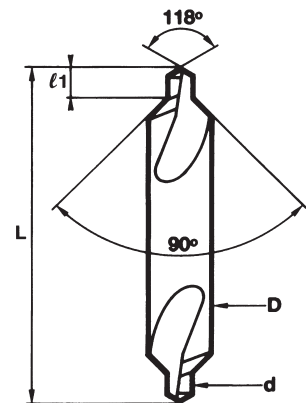

Code 195: 90° HSS M35 (5%) Cob

Code 895: 90° HSS M35 (5%) Cob TiN coated

Code 995: 90° HSS M35 (5%) Cob Futura coated

Code 196: 120° HSS M35 (5%) Cob

Code 896: 120° HSS M35 (5%) Cob TiN coated

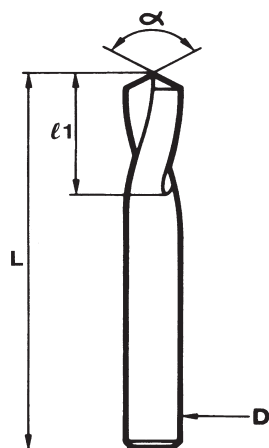

D	D"	L	l1	M35	TiN	Futura
				Price £	Price £	Price £
2		49	8	8.20	12.15	12.60
3		50	10	6.55	10.15	10.85
4	1/8	50	10	6.70	10.25	10.95
5		52	12	6.70	10.70	11.40
6	3/16	60	15	6.95	11.25	12.00
8		60	15	6.95	11.35	12.15
10	1/4	66	20	7.25	12.60	13.40
12		66	22	7.25	13.85	14.65
14	3/8	79	25	8.00	15.00	15.90
16		89	25	9.85	17.10	18.20
18	1/2	89	25	9.85	17.25	18.35
20		102	30	12.40	23.85	25.05
25	5/8	102	35	12.40	24.85	26.25
30		115	35	20.10	32.75	34.70
35	3/4	115	35	20.10	34.30	36.30
40		115	35	20.10	34.50	36.50
45		130	40	32.90	58.40	62.35
50	1	130	40	32.90	61.15	65.10
55		130	40	32.90	61.55	65.50
60		138	45	56.65	84.45	89.20
65		138	45	56.65	90.80	94.75

Code 197: Long Series 90° HSS M35 (5%) Cob

Code 199: Long Series 120° HSS M35 (5%) Cob

D	D"	L	l1	Price £
3		80	10	31.55
4		100	12	30.20
5		120	15	31.35
6		140	20	32.75
8	1/4	140	22	33.75
10		140	25	36.70
12	3/8	170	25	52.90
14		170	25	53.65
16	1/2	170	30	57.20
18		170	35	59.20
20	5/8	200	35	71.85
22		200	35	72.20
24	3/4	200	40	87.60
26		200	40	88.40
28	1	200	45	112.10

Reamers

Centre Drills & Spotting Drills

Countersinks & Counterbores

Slot Drills & End Mills

Taps & Dies

TUSA Carbide Tooling

Code 8195: 90° Carbide K15 micrograin

Code 8196: 120° Carbide K15 micrograin

D	L	ℓ1	Price £
2	40	8	26.00
3	45	12	7.25
4	50	15	8.15
5	50	18	9.80
6	50	21	11.45
8	60	25	17.85
10	70	27	26.15
12	70	27	34.80
14	75	30	55.35
16	75	30	64.25
18	100	33	106.40
20	100	33	126.65

Code 8197 : Long Series 90° Carbide K15 micrograin

Code 8199 : Long Series 120° Carbide K15 micrograin

D	D"	L	ℓ1	Price £
4		100	12	71.40
5		120	15	87.40
6		140	20	98.85
	1/4	140	22	100.50
8		140	25	119.35
	3/8	170	25	157.80
10		170	25	158.65
12		170	30	188.35
	1/2	170	35	194.10
	5/8	200	35	321.05
16		200	35	322.65
	3/4	200	40	468.45
20		200	40	476.65

Code 007 : Combi-Mag Multi function Tool 90° Point

Hss-Co Red-X Coated

D	D"	L	ℓ1	T	Price £
3	1/8	50	6	0.3	11.55
4		52	8	0.4	12.00
5	3/16	60	10	0.5	12.75
6		66	12	0.6	14.00
	1/4	66	12	0.6	15.25
8	5/16	79	14	0.8	16.50
10	3/8	89	16	1	18.95
12		102	18	1.2	26.70
	1/2	102	19	1.3	27.90
14		115	21	1.4	36.35
16	5/8	115	24	1.6	38.15



for Quality & Service

www.toolex.co.uk

