

CPM Drainage

- Pipes
- Manholes
- Caissons
- Gully Pots
- Box Culverts

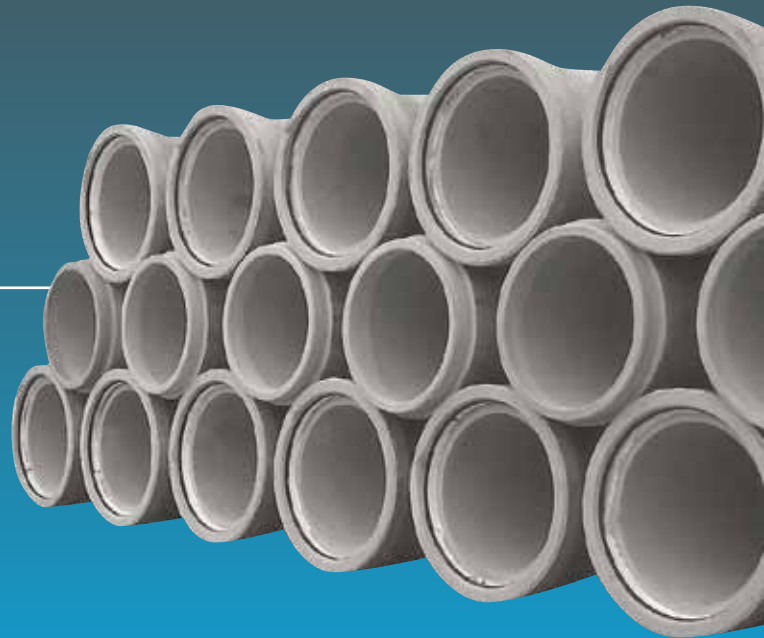
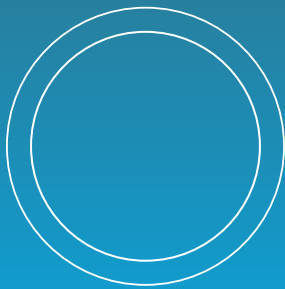

Welcome to CPM

CPM is a market-leading manufacturer of precast concrete products with extensive production facilities across the UK. This combined with a network of specialist distributors, enables us to provide our customers with complete UK coverage.

The CPM business is built on a solid reputation for delivering quality products and providing a first class service with diversification and innovation a key to our strength. We supply a vast range of sustainable precast concrete products to every sector of the construction industry, fully supported by our experienced technical and engineering teams.

CPM – Concrete for Life

CPM drainage products are designed and manufactured to British/European Standards and/or other customer requirements, and are kitemarked and CE Marked where applicable (only products covered by Harmonised Standards can be CE Marked). Our objectives are not only to continue to meet these requirements, but also to provide a high standard of service in a professional manner, to supply products that are competitively priced, to work with customers, suppliers and designers on developing our product range, to develop user loyalty and so achieve strong business performance.

To meet our objectives, the company applies a quality management system which has been developed in accordance with the requirements of ISO 9001 certification.

CPM – Build on our strength

The CPM team of engineers and technicians are at the forefront of precast concrete technology with BIM (Building Information Modeling), AutoCAD drawings, designs, calculations and installation advice being just some of the benefits we provide and all our design work is fully supported by professional indemnity insurance for peace of mind.

Quality and Accreditation



Please note that all weights and dimensions are approximate and subject to change. A copy of CPM's terms and conditions is available at www.cpm-group.com

+ Product Index

02-03

Welcome to CPM Group / Product Index

04-05

Flexible Jointed Pipes

06-07

Rocker Pipes / Butt Pipes / Uni Junctions / Ovoid Pipes

08-09

Tumbling Bay / Drawings

10-11

Pipe Handling / Pipe Jointing

12-13

Pipe Jointing / Air Testing

14-17

Traditional Manholes / Soakaway Chambers / Special Cover Slabs

18-19

House Inspection Chambers

20-23

Caissons / Adjusting Units

24-25

Gully Pots

26-35

The Perfect Manhole System

36-39

Box Culverts

40-41

Integrated Ladder System / Catch-pit / Silt Chamber Systems

42-43

Preformed Manholes / L Shape Retaining Walls

Flexible Jointed Pipes

CPM offer an extensive range of precast concrete flexible jointed pipes from 225mm to 1800mm to BS EN 1916:2002 Class 120 for use in both foul and surface water applications. All precast concrete pipes manufactured to DC Class 4 of BRE Special Digest 1.

Nominal Size	A	B	C	Angular Deflection	Joint Type			Approx Weight Of Pipe	Rocker Pipe Length	Butt Pipe Length
DN	mm	mm	mm	Degrees	'G'Ring	Integral	Lamell In wall joint no bell socket	kg	mm	mm
225	1250	380	295	2.90	●			122	600*	600
300	1250	480	410	2.40		●		217	600*	600
300	2500	497	410	2.40		●		420	600*	600
375	2500	575	490	1.90		●		510	600	600
450	2500	675	575	1.60		●		705	600	600
525	2500	760	670	1.40		●		900	600	600
600	2500	850	770	1.20		●		1200	1000	600
675	2500	980	820	1.05		●		1275	1000	1000
750	2500	1060	980	0.95		●		1924	1250	1000
825	2500	1143	985	0.90	●			1820	1250	1250
900	2500	1235	1080	0.80		●		1920	1250	1250
1050	2500	1420	1260	0.70		●		2590	1250	1250
1200	2500	1590	1440	0.60		●		3550	1250	1250
1350	2500	1840	1620	0.53	●			4600	1250	1250
1500	2500	1810	1810	0.48			●	5230	1250	1250
1600	2500	1920	1920	0.44			●	5702	1250	1250
1800	2500	2160	2160	0.40			●	7150	1250	1250

Table dimensions are for guidance only (as these may vary). For accurate dimensions and weights please contact the Technical team on 01902 356220 or technical@cpm-group.com

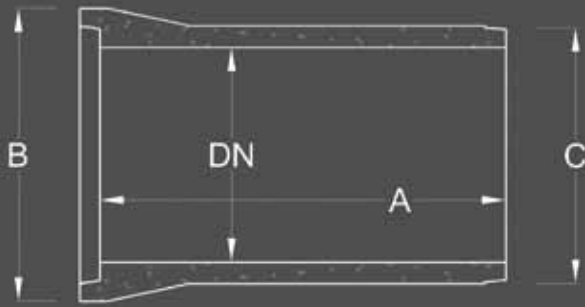

For DN 225 up to DN 1350

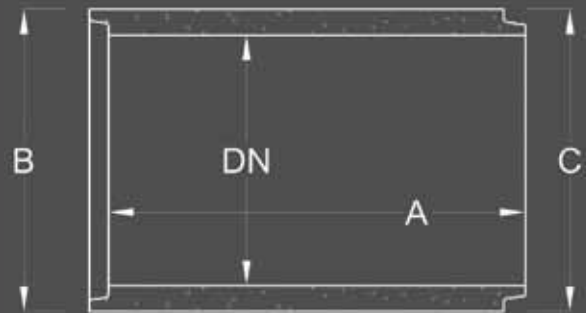

For DN 1500 up to DN 1800 / In-wall joint

Perforated Pipes

CPM manufactures precast concrete perforated pipes up to 1800mm diameter that transport and distribute storm water into the rock filled trench and eventually into the surrounding area through the circular perforations. Concrete perforated pipes are suitable for field drains or french drains.



Perforated pipes comply with the Department of Transport Specification for Highway Works, which requires the total area of drainage holes should not be less than 1000mm² per metre length of pipe.

Notes:

1. Seals are normally SBR complying with BS EN 681-1:1996. Other compounds such as Nitrile or EPDM can be supplied but may not be available from stock.
2. Pipes supplied with an in wall joint - no bell socket (full flexibility at joint maintained).
3. CPM specialised Flexi-lift system for handling/jointing purposes for pipes DN1200 to DN1800 is available.
4. Lorries with crane off load facilities are available for pipes up to DN 600 upon request, although site assistance would be required on certain diameters.
5. When ordering pipes which may have to joint with pipes already on site or previously laid, particularly extensions to contracts, it is important to advise the sales office accordingly in order to eradicate any jointing problems.
6. CPM lubricant is advised for use on integral pipes, CPM cannot guarantee that the jointing of concrete pipes with the use of other lubricants will be successful.
7. Lifting and Handling DN225 - DN1050 Straps / Pipe lifter DN1200-DN1800 Flexi-lifting / jointing chains.

Rocker Pipes / Butt Pipes

Butt pipes and rocker pipes allow for any differential settlement between the manhole and the pipeline, with the spigot/socket butt pipe being built into the manhole wall. A rocker pipe is then laid connecting the butt pipe to the incoming/outgoing pipe run, thereby incorporating a flexible joint close to the manhole.

Rocker Pipe



Nominal Size	Effective Length
DN	mm
225 - 600	600
675 - 750	1000
825 and above	1250

Spigot Butts



Nominal Size	Effective Length
DN	mm
225 - 600	600
675 - 750	1000
825 and above	1250

Socket Butts



Junctions

Branches of 100mm upwards can be fitted into all pipe sizes. Branches can be made from drainage materials other than concrete and are normally fitted to both full and short length pipes to suit customer requirements.

Uni Junctions

CPM uni-junctions are 150mm diameter connections to suit pipes from 300mm up to 1800mm. The uni-junction is an alternative to a fixed branch junction and offers the following advantages:

- Quicker and easier installation
- Less susceptible to site and transport damage
- Allows for more flexibility when positioning the branch along the pipeline
- Greater flexibility being able to accommodate a range of pipe material using adaptors
- Angular connections can be made using bends

The uni junction is designed to suit 150mm supersleve clay pipes not slimline clay pipes. To connect to plastic pipes, an adaptor coupling from the clay to the plastic pipe will be required. Alternatively for certain plastic pipes an adaptor bush is available. Contact our Sales office for full compatibility details. For information on bends and tumbling bay junctions, please visit www.cpm-group.com

Uni Juntions

All junctions are to be fitted on their side. Junctions are not designed for vertical surface compaction and need to be surrounded in concrete.



Ovoid Flexible Jointed Pipes

CPM offers a range of concrete ovoid pipes including a flexible joint seal for use with both foul and surface water applications. The ovoid concrete pipe is produced and tested in accordance with the relevant provisions of BS EN1916:2002/BS5911-1:2002 Class 150 including dimensional tolerances, crushing, hydrostatic, water absorption and joint tests.

- Lower operating costs, where some sewers may be laid without the need for pumping.
- Better self-cleansing and therefore less risk of siltation and blockage
- Reduced costs of trench excavation resulting from shallower gradients



Nominal Internal Size		Effective Length	Approx Weight	Handling & Jointing
width (mm)	height (mm)	mm	kg's	
400	600	1250	910	'C' Hook
600	900	2500	2170	Lamell
800	1200	2500	3300	Lamell

Tumbling Bay / Oblique

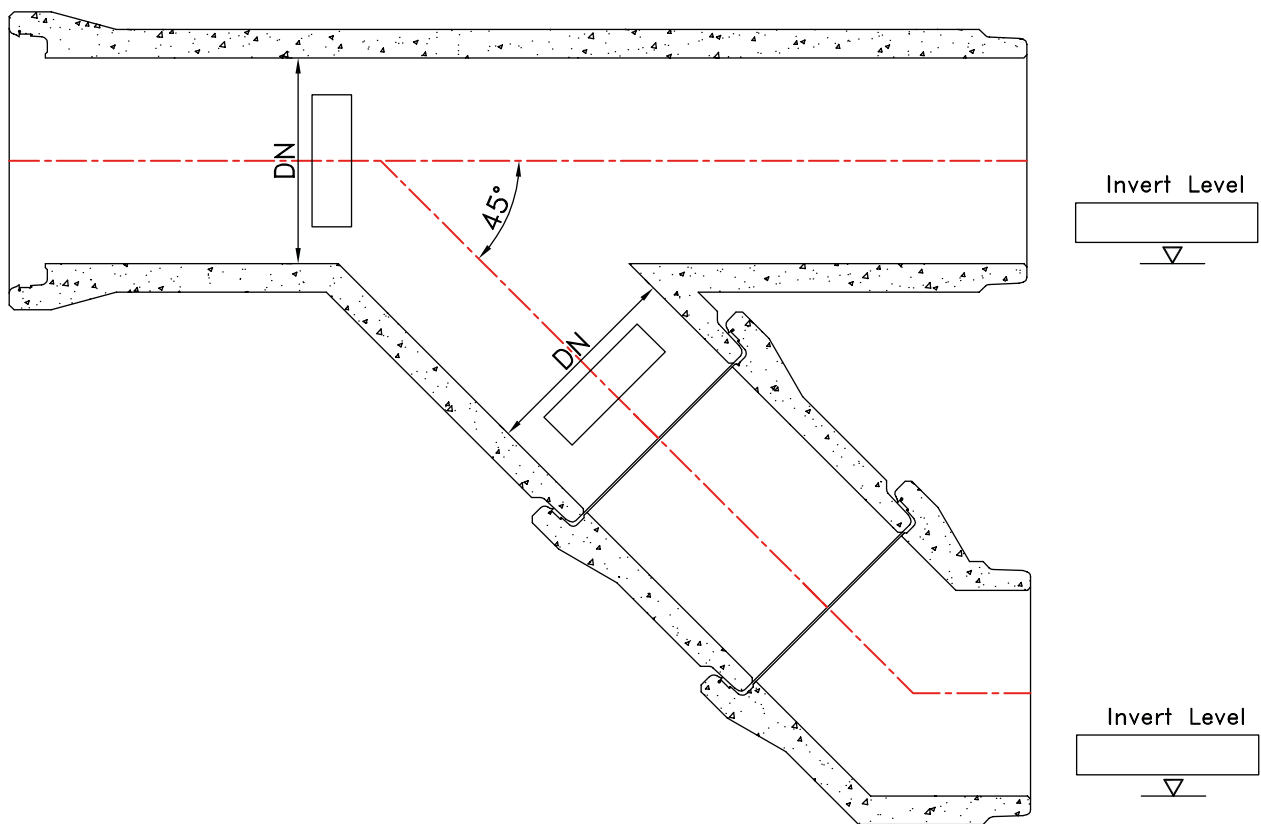

Instructions as to use:

Please supply pipe diameter and invert levels only.
CPM will complete and return for customer approval.



All dimensions exact diameter $\pm 100\text{mm}$
All bends are manufactured to $\pm 4^\circ$ Tolerance

Tumbling Bay / Square

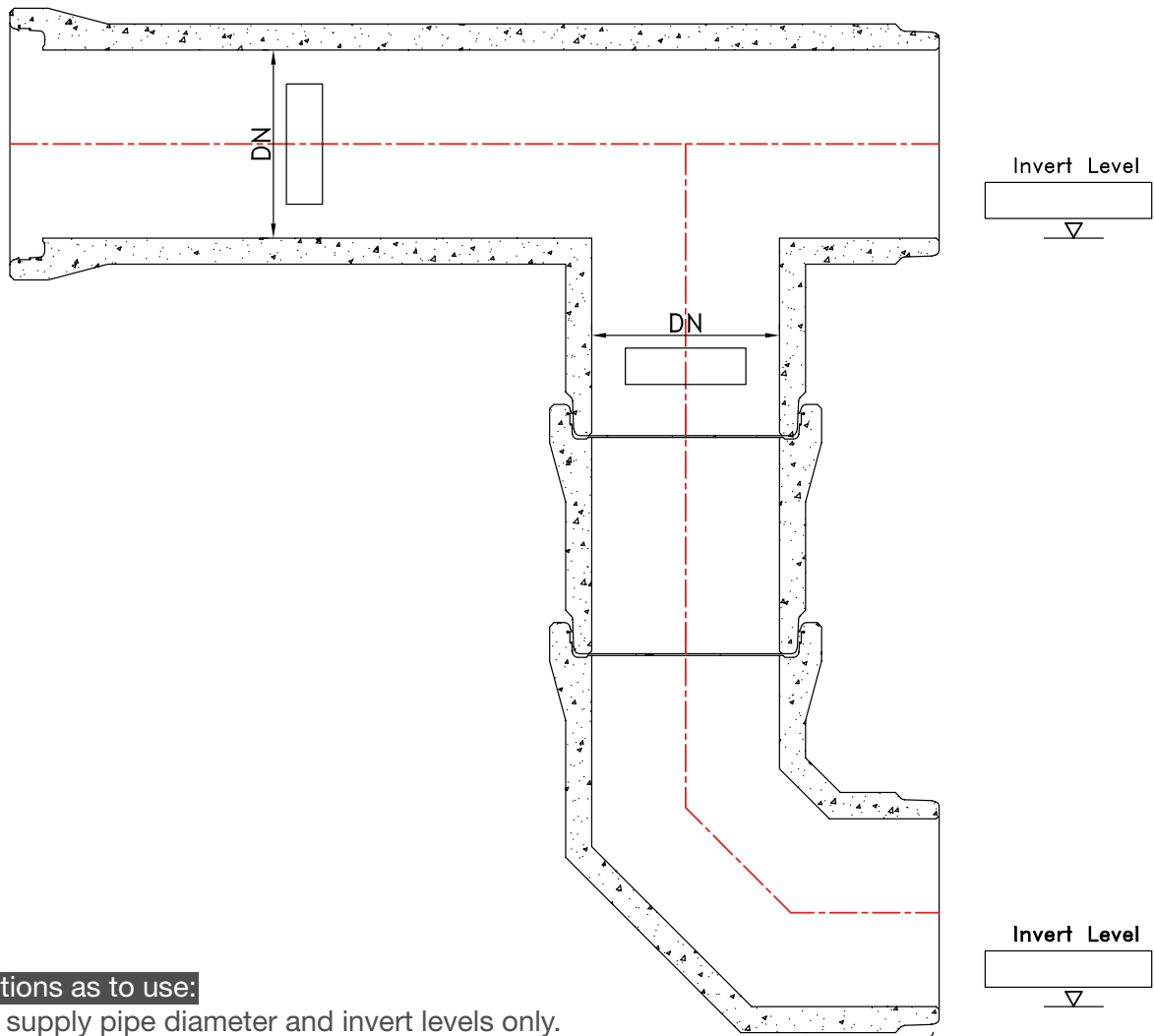

All dimensions exact diameter $\pm 100\text{mm}$
All bends are manufactured to $\pm 4^\circ$ Tolerance

CPM recommends that prior to laying the pipeline all products and equipment are checked to ensure that they are in good working order.

Handling of flexible jointed pipes

1. Avoid damage when handling, especially to ends of concrete pipes and never drag or roll pipes over rough ground.
2. Use correct craneage for offloading, utilising canvas/fabric slings with central lift or if ordered, large diameter pipes incorporate lift pins for which the propriety head link and chain set can be used.
3. Pipes should be handled individually using a properly designed 'C' hook, beam sling or other purpose-designed system. Small diameter pipes may be slung through the order to avoid damage to jointing surfaces and consequent leakage of the laid pipe.
4. Pipe lifters are available that are designed to improve site safety and speed up installation. The pipe lifter removes the need for operatives to be placed on the back of vehicles, eliminating working at height during off-loading of deliveries. Please visit www.concretepipes.co.uk/pipe-laying-lifting for more detail or email sales@cpm-group.com
5. Joint rings (when supplied loose) must be stored away from sunlight, heat or possible contact with any oils.
6. Stack pipes on even ground on timbers to protect sockets and spigots, making sure the bottom row is securely chocked.

For Integral seal joints

- Remove the protective polystyrene strip by using the tape provided (where necessary)
- Grip the tab of the tape and pull firmly towards the centre of the pipe (where necessary)
- Lubricant should be applied to the spigot end of the pipe, ensuring the radius area and entire length of the spigot is covered.
- Enter the spigot carefully into the socket and ensure that the pipes are correctly aligned.

Additional lubricant may also be applied to the seal face to assist jointing.

CPM integral pipes should only be jointed using a CPM approved lubricant which is available from our sales team on 01179 812791 or email sales@cpm-group.com. CPM cannot guarantee that the jointing of concrete pipes with the use of other lubricants will be successful.

For rolling ring joints ('G' ring)

- Stretch and position the seal onto the spigot of the pipe and ensure it is not twisted. Even out the stretch by lifting and releasing at several points around the spigot.
- Offer the pipe spigot to the socket, but keep clear of engagement by 25mm so that the joint ring is not disturbed.
- Enter the spigot carefully into the socket ensuring that the gasket is correctly positioned and that the pipes are correctly aligned.
- Under no circumstances should the joint be lubricated.

For larger pipes use of 'Flexi-lift' lifting/jointing chains

For 1200mm pipes and above, plus larger size ovoid pipes, CPM recommends the use of the 'Flexi-lift' lifting system where special lifting anchors can be cast into the concrete pipes at manufacture.

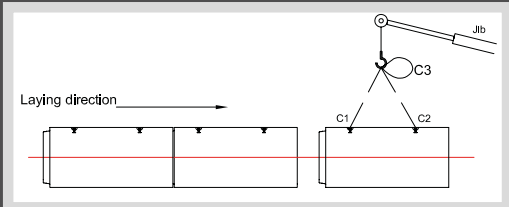
- 

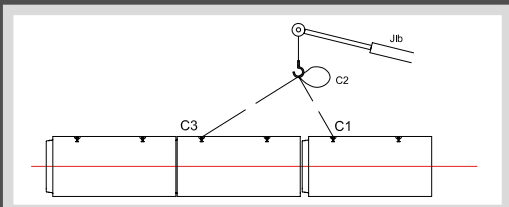
1. Use the equal length chains C1 and C2 for lifting and placing each pipe in the trench.
- 

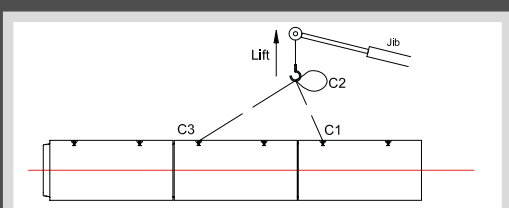
2. Connect the longer length chain, C3, to the pipe already laid and place the shorter length chain, C2 on the hook provided.
- 

3. The pipe can then be jointed without moving the jib of the crane.

Lamell Joints

- Correctly position and bed the first pipe. Prepare the bedding for the second pipe and hollow out for incoming spigot to prevent bedding material entering the joint.
- Check the spigot profile for cleanliness and that the seal is the correct size. Place the seal on the spigot (as Fig 1) with the small step on the underside.
- It is important that the seal is placed squarely back against the shoulder on the spigot and that the stretch is even around the gasket. This is achieved by lifting and releasing the gasket at opposite quarter points on the circumference.
- Ensure that the socket of the previous pipe is wiped free of dirt and grit and reasonably dry. Under no circumstances should the joint be lubricated. Enter the spigot checking that the pipes are correctly aligned.
- The joint may now be closed whilst the pipe is still supported by the crane. Check and pack, if necessary, the bedding material beneath the pipe barrel. An internal joint gap of between 10-25mm should be obtained upon completion of jointing.

Jointing

1. Correctly position and bed the first pipe. Prepare the bedding for the second pipe and hollow out for incoming spigot to prevent bedding material entering the joint.
2. Ensure the joint ring (where supplied loose) is of the correct size, is not twisted, is correctly located on the pipe spigot and the right way round.
3. Ensure the pipe spigot and socket are clean and undamaged.
4. Lubricants must not be used where 'G' and Lamell rings are supplied. Lubrication is required with the superseal integral joint (use of CPM lubricant is recommended).
5. Ensure the pipe to be jointed is adequately supported. The spigot should be centred carefully in the socket before jointing is completed, making sure bedding material does not enter the joint at any time.

For more detailed information on jointing see CPM Drainage Systems 'Concrete Pipes Installation Manual' at www.cpm-group.com

'G' ring - no lubrication

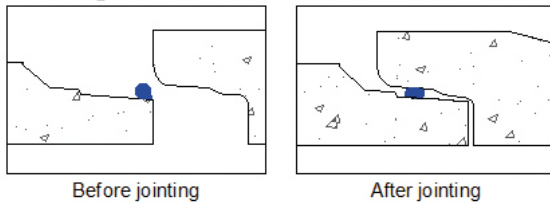

Lamell seal - no lubrication

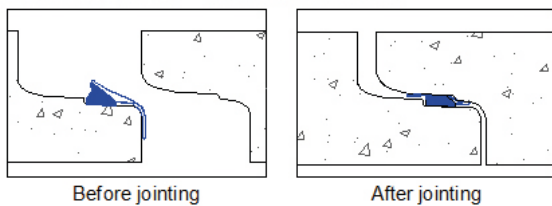

'Superseal' Integral seal - lubricated

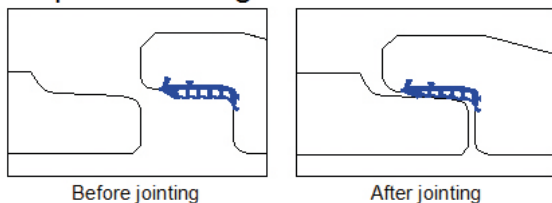

Air Testing

The air test is not covered by the European Standard, but a pipe which complies with the standard will usually comply with the air test. Failure to pass the air test will not normally preclude the acceptance of the pipeline if a successful water test can be achieved.

Ensure the test equipment is in good condition.

Inflatable stoppers are recommended for ease of use.

The test should be carried out after every 3 or 4 correctly laid and jointed pipes prior to commencement of backfill.

A successful test is achieved if the equipment shows a fall in pressure of no more than 25mm after 5 minutes, having allowed a suitable period for stabilisation.

If the pressure falls sharply and the pipes appear to have failed, the following checks must be made before contacting CPM for assistance:

- (a) Check the test equipment is in good condition
- (b) Check if the stoppers are leaking - use industrial soap around the edge of the stopper to provide an effective seal if necessary
- (c) Check the joint rings are correctly located

Dramatic temperature changes both inside and outside of the pipe could affect the air test. Reference should be made to BS EN 752.

If after following this guidance you still have problems with our product, please contact the supplying works in the first instance, on the following telephone numbers.

■	Mells Works	01179 812791
■	Pollington Works	01405 860591
■	Newmains Works	01698 386922
■	Technical	01902 356220

CPM regrets that failure to follow the advice given may result in any subsequent claims being invalid or in a call out charge being made if CPM technical personnel have to attend on site.

Traditional Manholes / Soakaway Chambers

CPM precast concrete chamber rings are manufactured with tongue and groove joints and comply to BS EN 1917:2002/ BS 5911-3:2010 and are supplied with three nominal 50mm diameter holes for lifting purposes.

DN	Available depth of section				Approx wall thickness	O.D.	Approx weight /m-depth
	0.25m	0.50m	0.75m	1.00m			
mm					mm	mm	kg
900	●	●	●	●	70	1040	530
1050	●	●	●	●	80	1210	710
1200	●	●	●	●	90	1380	912
1350		●	●	●	95	1540	1080
1500		●	●	●	105	1710	1330
1800		●	●	●	115	2030	1760
2100		●	●	●	125	2350	2140
2400		●	●	●	140	2680	2740
2700		●	●	●	150	3000	3400
3000		●	●	●	165	3330	4140
3660+		●	●	●	185	4030	5300
4000+			●	●	200	4400	6360

+ 3660mm and 4000mm are not covered by the British Standard, but comply with all the relevant provisions of BS EN 1917/5911-3:2010. 4000mm units are supplied in two halves.

Largest pipe diameter	Chamber diameter mm
Less than 375	1200
375 - 450	1350
500 - 700	1500
750 - 900	1800

Recommended minimum chamber diameters to suit pipe sizes.

Chamber sections can be supplied with:

- Fixed double steps or integrated ladder system
- Holes, cut-outs or bases cast-in
- CPM strip and primer

Safety Notice:

For safety reasons, all chamber sections are loaded and delivered chimney fashion. When offloaded, they should never be stored on their side (on the roll), but should always be laid flat. Offloading facilities are available upon request up to 3000mm. Suitable lifting bolts for offloading and handling purposes can be purchased from CPM. All lifting equipment comes with the appropriate test certificates. Please call 01179 812791 and speak to a member of the sales team or email sales@cpm-group.com

Soakaway Units

Standard chamber rings can be perforated with 75mm diameter holes for use as soakaways, providing a minimum area of exfiltration of 50,000mm² per metre of nominal diameter per metre of depth.



Chamber Section

Standard number of perforations per section

DN (mm)	0.50 m Deep	0.75 m Deep	1.00 m Deep
900	6	9	12
1050	8	12	16
1200	8	12	16
1350	8	12	16
1500	10	15	20
1800	12	18	24
2100	12	18	24
2400	14	21	28
2700	16	24	32
3000	18	27	36
3660	N/A	33	44
4000	N/A	36	48



Rectangular Manholes

Rectangular manhole units have a tongue and groove joint and are manufactured and tested in accordance with BS En1917:2002/BS5911-3:2010

These units comply with the recommendations in the Water Services Association publication Sewers for Adoption, where the manhole from ground level to the soffit of the pipes is 1.45m or less, in light or main road situations.

Manhole Section	Internal Dimensions (mm)	External Dimensions (mm)	Depth mm	Aprox Weight (kg)	Palletisation		
					No. Per Pallet	Approx Weight (kg)	Banded Pack Size
Cover (heavy duty)	1200x675 access	1510 x1060	125	239	5	1195	
Cover (heavy duty)	600 x 600 access	1380 x930	150	300	5	1800	
Cover (light duty)	600 x 600 access	1366 x916	90	180	5	750	
Chamber	1200 x 750	1350 x900	150	115	8	920	8
Chamber	1200 x 750	1350 x900	225	173	5	865	5

Note: For rectangular manholes use 12mm x 60mm sealant *1475 x 1025 available un-kitemarked please telephone our sales team: 01179 812791

Sealant Size	12mm x 60mm		12mm x 80mm				12mm x 120mm				12 x 75mm	12 x 25mm
	900	1050	1200	1350	1500	1800	2100	2400	2700	3000	3660 / 4000	4000 Vertical
Sealant length (per joint)	3.5m	4.0m	4.5m	5.0m	5.5m	6.5m	7.5m	8.5m	9.5m	10.5m	13.5m / 16.5m	2.5m
Primer	5 Litres / 100m		5 Litres / 75m				5 Litres / 50m				None required	

Cover Slabs

CPM offer a range of standard heavy duty cover slabs from DN900 to DN4000 to BS EN 1917:2002/BS 5911-3:2010 as well as a wide range of standard specials which are outside the British and European standard but are regularly used throughout the industry as well as a bespoke range of 'one offs' that require that "extra special something".



Chamber DN	Maximum Thickness	Overall DN	Standard Access Sizes (mm)					Weight 675 ² access
			600 x 600	675 x 675	750 x 750	750 x 600	1200 x 675	
mm	mm	mm						kg
900	150	1230	C	C	X	X	X	235
1050	150	1230	E	E	C	E	X	235
1200	150	1400	E	E	To order*	E	X	356
1350	150	1560	E	E	To order*	E	C	503
1500	170	1730	E	E	To order*	E	C	890
1800	175	2050	E	E	To order*	E	E	1208
2100	178	2370	E	E	To order*	E	E	1745
2400	178	2700	E	E	To order*	E	E	2200
2700	205	3020	E	E	To order*	E	E	3380
3000	225	3350	E	E	To order*	E	E	4300
3660	275	3960	E	E	To order*	To order*	To order*	7940
4000	275	4500	E	E	To order*	To order*	To order*	10035

*Made to order / E=Eccentric / C=Central

Notes

1. All slabs detailed are Type 2.
2. For details of access position, contact the technical department on 01902 356220 or technical@cpm-group.com
3. 3660mm and 4000mm cover slabs are supplied in two sections and not kitemarked.
4. All accesses have 75 x 75 corner chamfers.
5. All cover slabs are 'heavy duty' and are suitable for use in main roads.
6. 1050mm cover slab 750 x 750 central opening is 1400 OD
7. 1350mm cover slab 1200 x 675 central opening is 1730 OD

Landing Slabs



Landing slabs to suit DN1500 chamber sections and above are manufactured with a 900mm circular access.

Reducing Slabs



Reducing slabs to suit up to and including DN4000 chamber sections are generally manufactured with a 900mm, 1050mm or 1200mm circular reducing section.

Reducing slabs are generally manufactured with a built in ring.



Special Cover Slabs

As demand for high loading and multi access cover slabs has risen, CPM has become experts in both the design and manufacture, producing a wide range of bespoke cover slabs that can be manufactured to customer's specifications.

Typical examples of special cover slabs supplied are:

- For pumping stations and incorporating davits and/or rebates
- Extra heavy duty slabs for airports and ports
- Extra-large accesses
- Slabs designed to comply with Highways Agency Specifications
- Multiple accesses
- Non-circular slabs
- Slabs with customers own reinforcement design

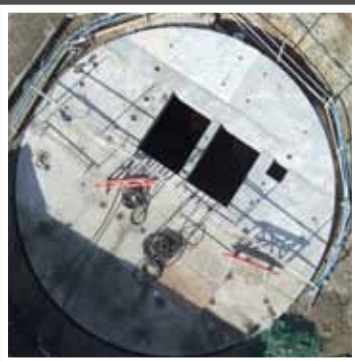

House Inspection Chambers

House Inspection Chambers

House Inspection chambers are easily handled and excavation below ground level is kept to a minimum. The CPM range of precast concrete inspection chambers are available in a variety of depths, economic and are manufactured to BS EN 1917:2002/BS 5911-4:2002

All units can be supplied banded as detailed in the tables on weights and dimensions.

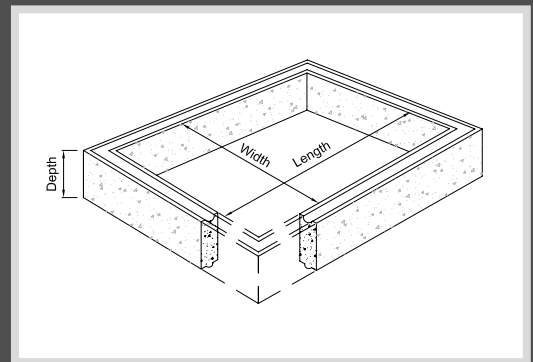

Internal Dimensions (mm)	Depth of Sections (mm)	Wall Thickness mm	Weight of Sections mm	Palletisation			
				No. Per Pallet	Approx Weight (kg)	Number Banded	Banded Pack Size (kg)
600 x 450	150	50	44	32	1410	16	512
600 x 450	225	50	58	20	1160	10	580
600 x 450	300	50	86	16	1380	8	690
750 X 600	150	60	67	16	1070	8	535
750 X 600	225	60	100	10	1000	5	500
750 X 600	300	60	134	8	1070	4	535
1000 X 675	150	65	83	16	1330	8	665
1000 X 675	225	65	130	10	1300	5	650

For depths in excess of 1.5m the use of a concrete surround is recommended.

Top sections for concrete covers weights and dimensions (All measurements in mm)

To suit chamber sections (mm)	Overall Dimensions (mm)	Effective depth of sections (mm)	Overall depth of sections (mm)	Weight of sections (mm)	Palletisation			
A x B	C x D	E	F	kg	No. Per Pallet	Weight (kg)	Banded pack size	Weight (kg)
600 x 450	845 x 680	110	120	46	10	1010	5	505
750 x 600	865 x 715	110	120	67	10	1220	5	610

Top sections for metal cover and frame weights and dimensions (All measurements in mm)

To suit chamber sections (mm)	Overall Dimensions (mm)	Effective depth of sections (mm)	Overall depth of sections (mm)	Weight of sections (mm)	Palletisation			
A x B	A x B	E	F	kg	No. Per Pallet	Weight (kg)	Banded pack size	Weight (kg)
600 x 450	825 x 675	60	85	42	10	420	5	210
750 x 600	870 x 720	50	60	44	10	440	5	220
1000 x 675	1150 x 825	50	60	89	10	890	5	445

Top sections for 750mm x 600mm and larger chambers act as reducing slabs, enabling standard 600mm x 450mm covers to be fitted irrespective of the size of chambers involved.

To provide concrete top section for 1000mm x 675mm requires:

1. Top section for metal cover and frame 1000mm x 675mm (i.e. reducer).
2. Top section for concrete cover 600mm x 450mm and concrete cover slab.

Concrete cover slabs are supplied to suit the top sections and are 695mm x 540mm overall, 60mm thick and weigh 55 kg.

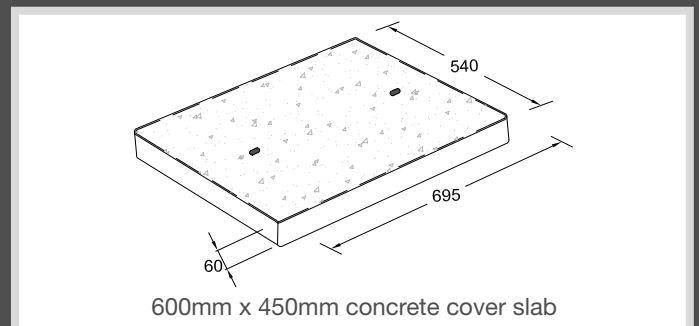
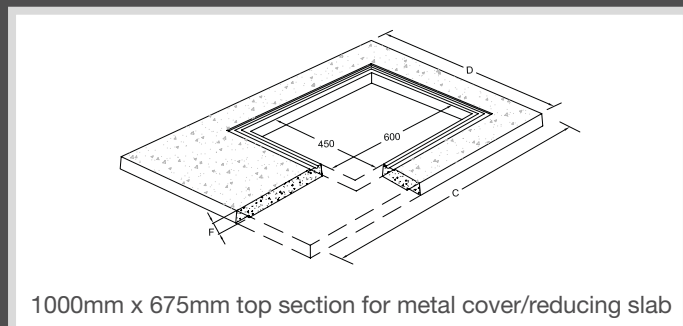
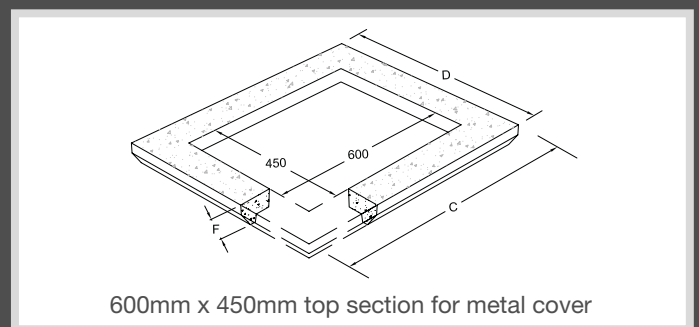
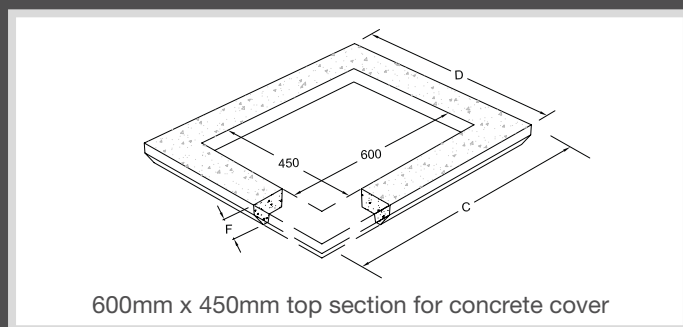

Caissons

Caisson Shaft Sinking System

CPM offer a range of reinforced precast concrete manhole units specially designed for sinking by the caisson method from 2000mm diameter to 4000mm internal diameter in varying depths.

This is achieved by using a shaft sinking plate system and is made in accordance to BS EN 1917:2002 and kitemarked where relevant to BS 5911-3:2010.



Advantages of the system include:

- Suited to weak soils, high-plasticity clays, silts, sands and gravel
- Minimal site labour costs
- Quick and easy to install
- Fast, clean accurate construction
- Immediate permanent shafts
- Suitable for jacking pits

The caisson shaft sinking system was originally designed for use in microtunnelling, but is now more widely used for construction of pumping stations, wet wells and manholes, particularly in difficult ground conditions.

Notes

1. 4000mm chambers are supplied in two half sections, each weighing approximately 3180 kg per metre, for assembly on site.
2. The steel cutting shoes provide a 10mm overbreak (20mm for 3660mm and 4000mm). Cutting shoes with a larger overbreak can be manufactured upon request.
3. The 3660mm and 4000mm steel cutting shoes are supplied in two sections.
4. Caisson lifting equipment is available for purchase from CPM on 01179 812791 or sales@cpm-group.com

Caisson Chamber Sections

DN	Wall thickness	Outside diameter	Effective depth	Overall depth	Weight per unit	Jointing plates
mm	mm	mm	mm	mm	kg	No.
2000+	130	2260	500	500	1065	3
2000+	130	2260	750	750	1598	3
2000+	130	2260	1000	1000	2130	3
2400	140	2680	500	522	1370	3
2400	140	2680	750	772	2055	3
2400	140	2680	1000	1022	2740	3
2740+	160	3060	500	500	1790	6
2740+	160	3060	750	750	2685	6
2740+	160	3060	1000	1000	3580	6
3000	175	3350	500	500	2135	6
3000	175	3350	750	750	3203	6
3000	175	3350	1000	1000	4270	6
3660+	185	4030	500	519	2660	6
3660+	185	4030	750	769	3980	6
3660+	185	4030	1000	1019	5300	6
4000+	200	4400	750	769	4770	6
4000+	200	4400	1000	1019	6360	6

+Non Kitemarked

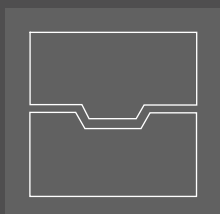

Note:

2400mm, 3660mm and 4000mm have a tongue and groove joint

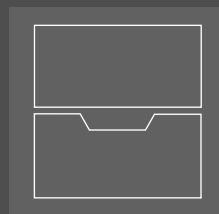

Note:

2000mm, 2740mm and 3000mm caisson rings have a flat and groove joint

Reference is strongly recommended to the Caisson Installation Guide available at www.cpm-group.com

Caisson Cover Slabs

Caisson cover slabs weights and dimensions

DN	Effective thickness	Overall thickness	Overall diameter	Approx weight (675 ²) Access
mm	mm	mm	mm	kg
2000	185	200	2370	1690
2400	163	178	2700	2200
2740	185	200	3060	3170
3000	200	225	3350	4300
3660*	260	275	3960	7940
4000*	260	275	4500	10350

*3660mm and 4000mm cover slabs are supplied in two halves



1. Reducing slabs are available, please contact sales for details on 01179 812791 or sales@cpm-group.com
2. A full installation guide is available for download at www.cpm-group.com/drainage/caissons

Reference is strongly recommended to the Caisson Installation Guide, as non-compliance may result in installation problems for which CPM can accept no responsibility.

Adjusting Units / Seating Rings



One piece cover frame adjusting units

Cover frame adjusting units are reinforced 65mm deep units which can be used in place of engineering bricks to adjust the ductile or cast iron covers and frames to the required level and are kitemarked to BS EN 1917:2002 / BS EN 5911-3 :2010

The use of adjusting units is specified in 'Sewers for Adoption'

Adjusting units are available for the following access sizes

Access Size (mm)	Depth mm	Weight kg
*600 x 600	65	70
675 x 675	65	65
750 x 600	65	70
750 x 750	65	80

Advantages are:

- Quick and easy to install using semi-skilled labour
- Fewer joints which reduce likelihood of infiltration
- All concrete units can be ordered from one source
- There is less risk of on site damage or pilferage

*600 x 600 Eccentric/ Corbel units have an eccentric opening which is used in conjunction with a 750 x 600 cover slab opening.

Two piece adjusting units are available with a 600mm² or a 675mm² opening.



Two Piece adjusting units

Cover frame adjusting units (previously known as seating rings) can be used in place of engineering bricks to adjust the final level of a cover and frame.

Access Size (mm)	Depth mm	Weight kg
600 x 600	65	48
750 x 675	65	60

Advantages are:

- Each section weighs less than 25kg for easy handling
- No requirement for skilled bricklayers due to ease of installation
- Quicker to install than brickwork

Scottish Water seating slab (Lothian Slab)

Special seating slabs 1125 x 1125 x 150mm thick, to comply with Scottish Water Services Specification are available with access sizes of 600 x 600, 675 x 675, 750 x 675, and 750 x 750.

Gully Pots

CPM gullies are typically used in highways and parking areas and are produced monolithically on fully automated machines, providing a strong robust unit that needs no concrete surround and are not subject to floatation.

Precast concrete road gullies can be supplied with adaptors for connection to clay or plastic pipes. CPM gullies are delivered inverted and should be offloaded, turned and handled using a webbing strap in choker fashion.

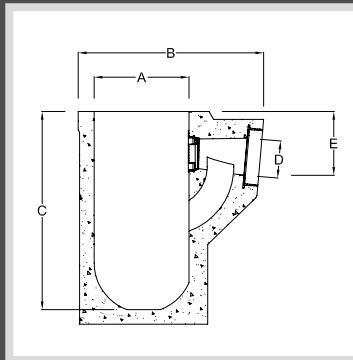

Gully weights and dimensions

DN	Nominal wall thickness	Width mm	Effective depth mm	Capacity	Approximate measurement mm	Outlet i/dia mm	Weight per unit	No. per full 23.5 tonne load
A	mm	B	C	Litres	E	D	kg	No
375	55	698	750	50	250	150	188	125
375	55	698	900	69	250	150	216	108
450	55	780	750	70	250	150	260	90
450	55	780	900	95	250	150	290	80
450	55	780	1050	120	250	150	320	73

Gully cover slabs

Gully cover slabs are available in both square and 'U' shaped, with handling recesses for lifting brackets and are designed as a seating for a gully grate and used on top of a 450mm gully. CPM gully cover slabs are quick to lay and sit flush to the kerb for enhanced stability, eliminating brickwork joint 'weakspots'.

Slab	Dimensions (100mm thick)	Kg (100mm thick)
Square	750 X 650	80
U	585 X 650	50

A 65mm thick version also available.

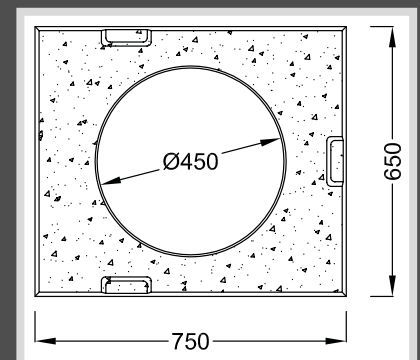
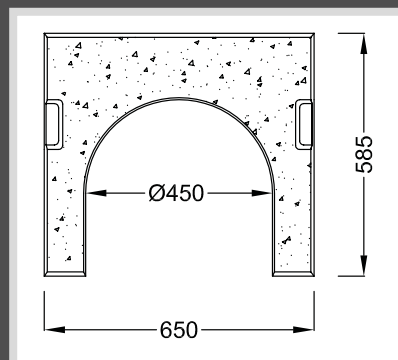

Gully Adaptors

The gully adaptor is a versatile elastomeric sealing adaptor ring manufactured in EPDM rubber to BS 2494 Type D. This table shows the tolerant of a range of pipe diameters and profiles - for use only with CPM Group kitemarked concrete gullies.

For pipes not included in the table, the following criteria should be used for selection of correct gully adaptor.

No. 1501 - Spigot diameter - 160mm to 180mm

No. 1502 - Spigot diameter - 175mm to 190mm

To Suit Pipe	Type of Pipe		Number of gully adaptor required to suit type of pipe	
			1501	1502
DN				
160	uPVC pipe to BS4660	plastic	•	
150	aquapipe - corrugated	plastic	•	
150	ultrarib	plastic	•	
150	twin wall PVC - corrugated	plastic	•	
150	supersleeve	clay	•	
150	densleeve	clay		•
150	hepseal	clay		•

Procedure for installation and selection of gully adaptor

1. Ensure the gully outlet socket is clean. Any hard points should be removed.
2. Fit adaptor into socket. The adaptor seals are designed slightly larger than the socket to ensure positive location and an effective seal. Care should be taken to even out the seal to remove folds, although if left, this will occur naturally.
3. Place pipe in adaptor and push home.

Lubricant requirements:

- i) Smooth plastic pipe - requires no lubricant.
- ii) Supersleeve pipe - can be jointed dry with care, but lubricant may be used to assist jointing.
- ii) Densleeve/Hepseal/Corrugated pipes - lubricant such as water/soap, silicone etc. is required for jointing purposes. In some instances for corrugated pipes it may be advisable to place the pipe in the adaptor prior to its location in the gully outlet.





The Perfect Manhole System

After an extensive research programme, CPM introduced the 1200mm perfect manhole system in October 2009 to meet the challenges of modern day construction. Today it is available in 1200mm, 1500mm and 1800mm diameters and comprises of a monolithic precast concrete base (available pre-benched in any configuration within just days of requisition), a sealed chamber ring (with a thicker wall than a traditional ring), a rubber joint (so no tokstrip or similar product is required) and a sealed cover slab (supplied with your required access).

For other sizes please Telephone: 01538 380500 / Email perfect@cpm-group.com

This unique system of products combine to form the CPM perfect manhole system; designed and manufactured to last a minimum of 120 years that provides a sealed manhole system that gives up to 40% savings on greenhouse emissions compared to traditional manhole construction and eliminates the need of ready mixed concrete to form the traditional base, chamber benching and further concrete to surround the manhole. A complete manhole can be installed in as little as 25 minutes, and making safe site practice a real winner when using the perfect manhole as it reduces the need to work in confined spaces and eliminates the need for wet trades resulting in rapid construction compared to traditional methods as well as a reduction in time for the excavation space to be open.

The Perfect Installation / Time Line

#1	#2	#3	#4	#5
				
17:05	17:10	17:15	17:20	17:25

Attributes of the Perfect Manhole System

✓ Build Greener	Up to 40% lower greenhouse gas emissions
✓ Build Leaner	Saves material and labour / No waste
✓ Build Faster	Speedy installation
✓ Build Safer	No confined space working, excavation closed quicker
✓ Build Quality	CPM's Perfect Manhole is produced in a quality controlled factory environment

Quality of the Perfect Manhole System

- ✓ Perfect Manhole complies with BSEN1917:2002 and BS5911-3.
- ✓ CPM's Perfect Manhole is accepted for use by all major UK companies and is included in Sewers for Adoption 7th edition.

The long term benefits

- ✓ CPM's Perfect Manhole is made from high quality durable concrete with a minimum of 120 year design life.
- ✓ Easy access for inspection - reduces maintenance and running costs.
- ✓ Watertight Manhole – prevents water infiltration into the manhole system and ex-filtration of raw sewage or dirty water from the manhole into the surrounding area.

The Perfect Manhole take off tool / Configurator

Available from CPM's website www.cpm-group.com is the perfect manhole take off tool and configurator. Just input your 1200mm or 1500mm manhole details and email to perfect@cpm-group.com and we will send you back a complete schedule and costs for your project.

Advantages / Perfect Manhole System



Safer construction

No requirement to form a concrete surround. Reduction of open excavation.



GHG savings

Up to 40% savings on GHG emissions compared with traditional construction.



Fast installation

The modular solution eliminates the need for wet trades resulting in rapid construction compared to conventional methods.



No need to surround in concrete unless specifically required

130mm wall thickness.



Available at short notice

Our modern methods of production enables just in time delivery of all components including bases at short notice.



Watertight

The combination of a thicker wall and rubber joints ensures a watertight structure.*



No water ingress into sewerage network reduces treatment costs

The combination of a 130mm wall and sealed rubber joint withstand 5m head of pressure.*



Combined seal includes load distributor

Load distribution ensures even distribution of vertical loads.



Allows joint inspection

Correct installation can be visually confirmed.



Fully tested under factory conditions

The whole system from base to cover slab is subject to testing.



Kitemarked solution manufactured under factory conditions

Complies with the requirements of BSEN 1917 and BS5911-3



Concrete for life – built to last.

High quality durable concrete with a minimum 120 year design life.



Flexible connections

The Perfect Manhole can be connected to plastic, clay, cast iron or concrete - giving you a larger choice.

*Watertightness is defined in BS EN 1917 as resisting a 5m head for 15 minutes. This is to simulate a temporary surcharge condition not a permanent head of water.

*Shafts in high water tables are subject to buoyancy effects. For further information please contact the CPM Group Technical team.

Ticking all the boxes



Efficient construction

Available in varying depths for efficient construction.



Base options

Available pre-benched or plain bottom with or without inlet / outlets.



Pre-fit options

Hydro-Brake®, penstocks, non-return valves, and filters can be pre-fitted in the factory.



Customer choice

The perfect manhole is available with or without double steps. Sealed chamber rings can be used without the perfect base.



Cover choice.

Each perfect manhole is available with a cover slab opening of 600 x 600mm, 675 x 675mm, 750 x 600mm or 1200 x 675mm

Extra Services



Full take-off service available.



Lifting apparatus available for fast, effective and safe handling.



Full installation guide available.



Hydro-Brake® / Penstocks and valves can be pre-fitted.

Available in 1200mm, 1500mm and 1800mm diameter

For other sizes please call 01538 380500 or Email perfect@cpm-group.com

Perfect Manhole / Diagrams

Customer		Product Reference	
Site		Originator	
Customers MH Ref			
Required fall across main channel (E1 To A0)			
Double steps position if Required (DEG)			
Outlet / Inlet Positions (DEG)	Pipe Size	Gradient	Pipe Type
Outlet - A0			
Inlet - E1			
Inlet - E2			
Inlet - E3			
Inlet - E4			

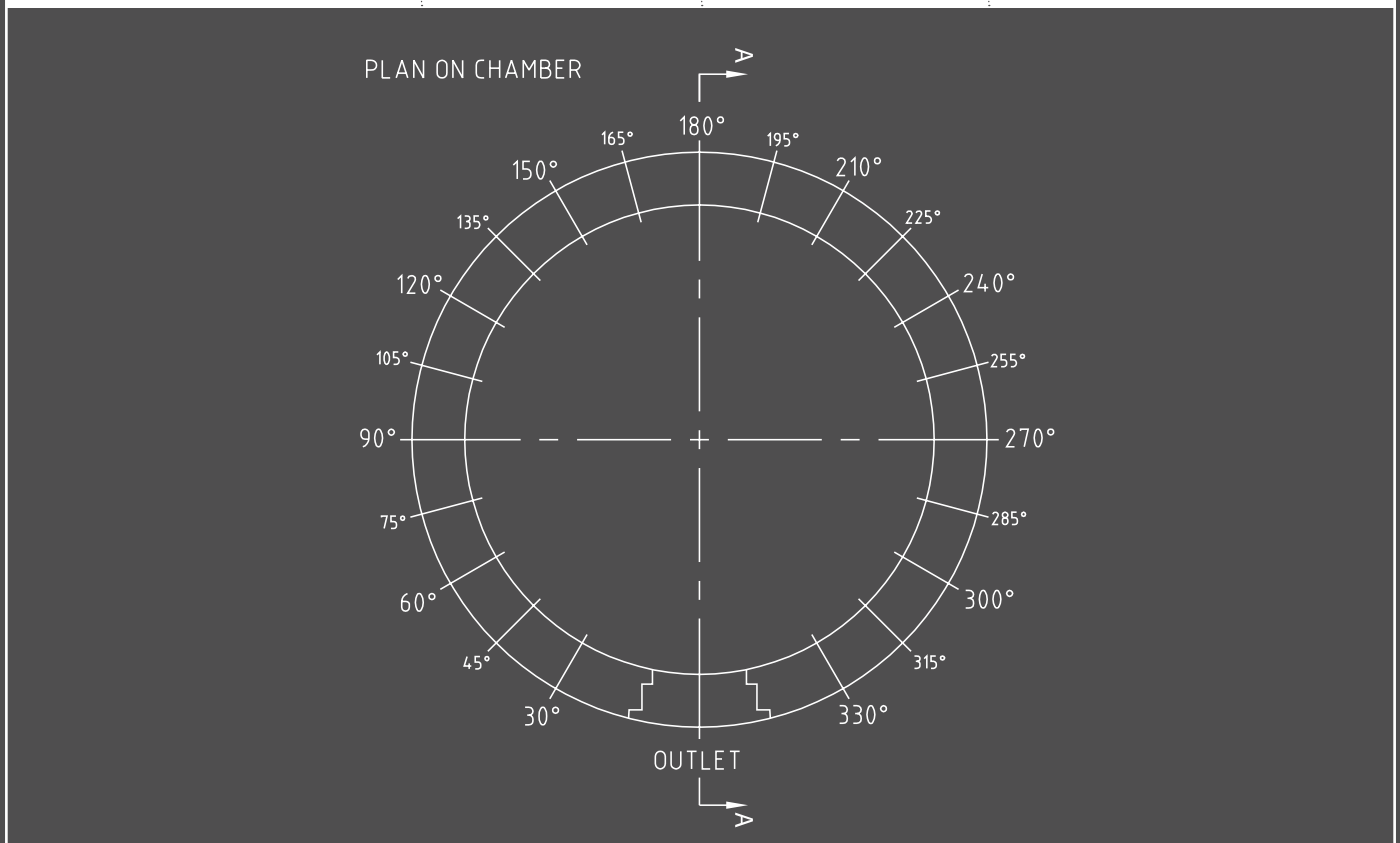

Please use this diagram to scan/photocopy and forward your requirements to perfect@cpm-group.com

Please note that there is a 1 in 9 gradient for the 1200mm perfect manhole and a 1 in 18 gradient for pipes 450mm upwards for the 1500mm perfect manhole and the angles between adjacent connection cannot be less than 24 degrees.

Perfect Manhole Dimensions / 1200mm

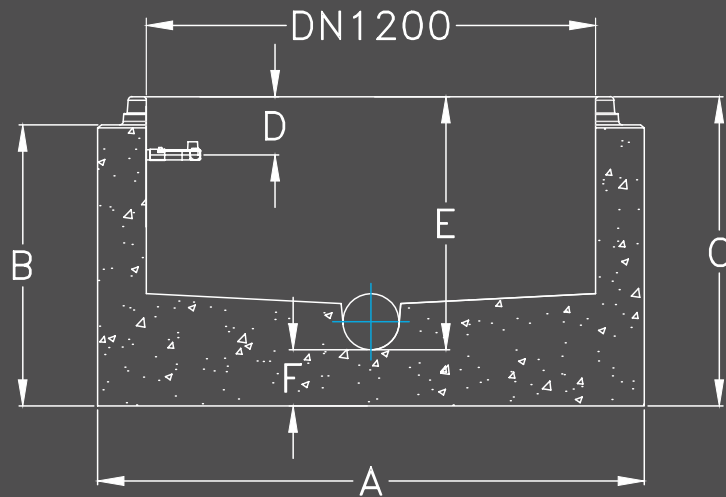

1200mm Standard Base Unit

Dimensions mm	A	B	C	D	E	F	G	Weight/(kg)
100 Diameter Outlet	1460	600	675	155	400	275	130	1820
100 Diameter Outlet	1460	675	750	155	475	275	130	1918
100 Diameter Outlet	1460	750	825	155	550	275	130	2016
150 Diameter Outlet	1460	600	675	155	450	225	130	1806
150 Diameter Outlet	1460	675	750	155	525	225	130	1904
150 Diameter Outlet	1460	750	825	155	600	225	130	2002
225 Diameter Outlet	1460	600	675	155	525	150	130	1755
225 Diameter Outlet	1460	675	750	155	675	150	130	1853
225 Diameter Outlet	1460	750	825	155	985	150	130	1951
300 Diameter Outlet	1460	675	750	155	600	150	130	1998
300 Diameter Outlet	1460	750	825	155	675	150	130	2096

1200mm chambers have a nominal fall of 20mm +/- 10mm north to south across the major incoming to outgoing inlets. G=Wall Thickness. Please note that all weights and measures are approximate.

Perfect Manhole Dimensions / 1500mm

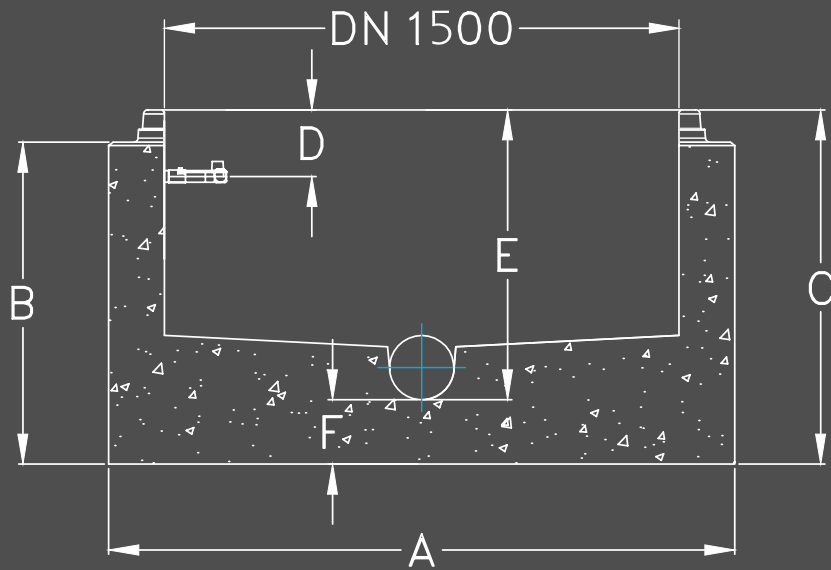

Typical Perfect Manhole Images



1500mm Standard Base Unit

Dimensions	A	B	C	D	E	F	Wall	Weight/(kg)
100 Diameter Outlet	1820	750	835	155	580	255	160	2900
100 Diameter Outlet	1820	825	910	155	655	255	160	3100
150 Diameter Outlet	1820	750	835	155	630	205	160	2900
150 Diameter Outlet	1820	825	910	155	705	205	160	3100
225 Diameter Outlet	1820	750	835	155	630	205	160	2900
225 Diameter Outlet	1820	825	910	155	705	205	160	3100
300 Diameter Outlet	1820	825	910	155	705	205	160	3100
100 Diameter Outlet	1820	900	985	155	730	255	160	3224
150 Diameter Outlet	1820	900	985	155	780	205	160	3195
255 Diameter Outlet	1820	900	985	155	780	205	160	3363
255 Diameter Outlet	1820	900	985	155	855	205	160	3514
300 Diameter Outlet	1820	900	985	155	780	205	160	3566
300 Diameter Outlet	1820	975	1060	155	855	205	160	3716
300 Diameter Outlet	1820	900	985	155	930	205	160	3867
375 Diameter Outlet	1780	975	1060	155	855	205	160	3772
375 Diameter Outlet	1820	1050	1135	155	930	205	160	3992
375 Diameter Outlet	1820	1125	1210	155	1005	205	160	4072
450 Diameter Outlet	1820	975	1060	155	855	205	160	3835
450 Diameter Outlet	1820	1050	1135	155	930	205	160	3985
450 Diameter Outlet	1820	1125	1210	155	1005	205	160	4135
450 Diameter Outlet	1820	1200	1285	155	1080	205	160	4522
525 Diameter Outlet	1960	1050	1135	155	930	205	230	5039
525 Diameter Outlet	1960	1125	1210	155	1005	205	230	5264
525 Diameter Outlet	1960	1200	1285	155	1080	205	230	5489
600 Diameter Outlet	1960	1125	1210	155	1005	205	230	4950
600 Diameter Outlet	1960	1200	1285	155	1080	205	230	5362
600 Diameter Outlet	1960	1275	1360	155	1155	205	230	5587
675 Diameter Outlet	1960	1125	1210	155	1005	205	230	5035
675 Diameter Outlet	1960	1200	1285	155	1080	205	230	5260
675 Diameter Outlet	1960	1275	1360	155	1155	205	230	5485
675 Diameter Outlet	1960	1350	1435	155	1230	205	230	5710

1500mm chambers have a nominal fall of 25mm +10mm/-13mm north to south across the major incoming to outgoing inlets. G=Wall Thickness. Please note that all weights and measures are approximate.

Perfect Manhole System / 1800mm

After the successful introduction of the 1200mm and 1500mm perfect manhole system, CPM has developed an 1800mm sealed manhole that can be used for precast concrete pipes up to 900mm diameter.

The system includes a cast-in base and incorporates the concrete butt pipes into the chamber base and pipe channel; this only leaves the benching to be completed on site.

By leaving the benching out of the base element, the weight of the unit is reduced to between 5.0 and 5.5 tonnes depending upon the configuration.

Deeper manholes are accommodated by using a reducing slab to a 1200mm sealed manhole.

The 1800mm Perfect Manhole system can be supplied with either double steps or with an integrated ladder system which is available from CPM.

As the 1800mm sealed manhole system is a bespoke precast product, standard measurements cannot be given as each is individual.

For further information please call 01538 380500 or email perfect@cpm-group.com

Typical Perfect Manhole Images



Perfect Manhole / Rings

Perfect Manhole Ring Typical Weights	
1200 Dimension mm	Weight kg
1200 x 1000	1180
1200 x 750	890
1200 x 500	590
1200 x 250	300
1500 Dimension mm	Weight kg
1500 x 1000	1750
1500 x 750	1310
1500 x 500	870

Perfect Manhole / Cover Slabs

Perfect Manhole Cover Slab Typical Weights (kg)				
Dimension	600 X 600 Access	675 X 675 Access	750 X 600 Access	1200 X 675 Access
1200	615	600	600	470
1500	1170	1120	1120	960

Please note that all weights and measures are approximate.

Box Culverts

Design chemical class DC-4 resistance

CPM's precast concrete box culverts are designed and manufactured in accordance with all current design specifications and relevant standards and are manufactured in both standard sizes available from stock and a bespoke range that is manufactured to customer specification, ensuring that those who require standard sizes as well as those who require something extra are catered for.

As well as culverts, CPM are able to include end walls, access points, vent holes, inlets, outlets, rungs and splayed ends. Starter bars and sockets can be added to facilitate any additional casting on site which may be required as part of the finished work.

The culverts can be supplied as standard units, on their side, vertical chambers and where being used as channels, cover slabs can be supplied separately if required

CPM box culverts suit a wide variety of applications such as:-

- Highways
- Storm and foul sewers
- Sea outfalls
- Tunnels and subways
- Underpasses
- Stream crossings
- Vertical chambers
- Open channels
- Road crossings
- Shafts
- Service tunnels and ducts
- Attenuation and storage tanks
- Water course diversion

An installation guide is available from www.cpm-group.com or call 01179 812791 for a copy or email sales@cpm-group.com

Typical Box Culverts



Box Culvert Range

Reference	Eff. Area	Internal Dimensions			External Dimensions		Normal Thickness		Approx Weight
* Stock Item	m.sq	Width m	Height m	Length m	Width m	Height m	Walls mm	Slabs mm	Tonnes
*MC 10.05	0.485	1.000	0.500	2.000	1.30	0.800	150	150	2.77
MC 10.07	0.735	1.000	0.750	2.000	1.300	1.050	150	150	3.14
MC 12.05	0.591	1.250	0.500	2.000	1.550	0.800	150	150	3.24
*MC 12.07	0.904	1.250	0.750	2.000	1.550	1.050	150	150	3.61
MC 13.06	0.826	1.375	0.625	2.000	1.675	0.925	150	150	3.61
MC 13.10	1.341	1.375	1.000	2.000	1.675	1.300	150	150	4.17
MC 15.07	1.065	1.500	0.750	2.000	1.80	1.050	150	150	4.12
*MC 15.10	1.440	1.500	1.000	2.000	1.80	1.300	150	150	4.49
MC 15.12	1.815	1.500	1.250	2.000	1.80	1.550	150	150	4.86
MC 15.15	2.190	1.500	1.500	2.000	1.80	1.800	150	150	5.24
*MC 17.07	1.252	1.750	0.750	2.000	2.050	1.050	150	150	4.49
MC 17.10	1.690	1.750	1.000	2.000	2.05	1.300	150	150	4.86
MC 17.15	2.565	1.750	1.500	2.000	2.05	1.800	150	150	5.63
*MC 20.10	1.940	2.000	1.000	2.000	2.30	1.350	150	175	5.79
MC 20.15	2.940	2.000	1.500	2.000	2.30	1.850	150	175	6.54
MC 20.20	3.940	2.000	2.000	2.000	2.30	2.350	150	175	7.20
MC 22.15	3.315	2.250	1.500	2.000	2.55	1.850	150	175	6.98
*MC 25.15	3.690	2.500	1.500	1.500	2.900	1.950	200	225	7.33
MC 24.07 A	1.740	2.400	0.750	1.500	2.800	1.200	200	225	6.050
MC 24.10 A	2.340	2.400	1.000	1.500	2.800	1.450	200	225	6.430
MC 24.12 A	2.820	2.400	1.200	1.500	2.800	1.650	200	225	6.730
MC 24.15 A	3.540	2.400	1.500	1.500	2.800	1.950	200	225	7.170
MC 24.18 A	4.260	2.400	1.800	1.500	2.800	2.250	200	225	7.620
MC 24.21 A	4.980	2.400	2.100	1.500	2.800	2.550	200	225	8.070
MC 27.07 A	1.965	2.700	0.750	1.500	3.150	1.250	225	250	7.370
MC 27.10 A	2.640	2.700	1.000	1.500	3.150	1.500	225	250	7.790

Reference	Eff. Area	Internal Dimensions			External Dimensions		Normal Thickness		Approx Weight
* Stock Item	m.sq	Width m	Height m	Length m	Width m	Height m	Walls mm	Slabs mm	Tonnes
MC 27.12 A	3.180	2.700	1.200	1.500	3.150	1.700	225	250	8.130
MC 27.15 A	3.990	2.700	1.500	1.500	3.150	2.000	225	250	8.630
MC 27.18 A	4.800	2.700	1.800	1.500	3.150	2.300	225	250	9.140
MC 27.21 A	5.610	2.700	2.100	1.500	3.150	2.600	225	250	9.640
MC 30.07 A	2.190	3.000	0.750	1.500	3.150	1.250	225	250	7.930
MC 30.10 A	2.940	3.000	1.000	1.500	3.450	1.500	225	250	8.350
MC 30.12 A	3.540	3.000	1.200	1.500	3.450	1.700	225	250	8.690
MC 30.15 A	4.440	3.000	1.500	1.500	3.450	2.000	225	250	9.190
MC 30.18 A	5.340	3.000	1.800	1.500	3.450	2.300	225	250	9.700
MC 30.21 A	6.240	3.000	2.100	1.500	3.450	2.600	225	250	10.200
MC 33.07 A	2.415	3.300	0.750	1.500	3.750	1.250	225	250	8.490
MC 33.10 A	3.240	3.300	1.000	1.500	3.750	1.500	225	250	8.910
MC 33.12 A	3.900	3.300	1.200	1.500	3.750	1.700	225	250	9.250
MC 33.15 A	4.890	3.300	1.500	1.500	3.750	2.000	225	250	9.750
MC 33.18 A	5.880	3.300	1.800	1.500	3.750	2.300	225	250	10.260
MC 33.21 A	6.870	3.300	2.100	1.500	3.750	2.600	225	250	10.760
MC 36.07 A	2.640	3.600	0.750	1.500	4.050	1.250	225	250	9.050
MC 36.10 A	3.540	3.600	1.000	1.500	4.050	1.500	225	250	9.470
MC 36.12 A	4.260	3.600	1.200	1.500	4.050	1.700	225	250	9.810
MC 36.15 A	5.340	3.600	1.500	1.500	4.050	2.000	225	250	10.310
MC 36.18 A	6.420	3.600	1.800	1.500	4.050	2.300	225	250	10.820
MC 36.21 A	7.500	3.600	2.100	1.500	4.050	2.600	225	250	11.320
MC 39.07 A	2.865	3.900	0.750	1.500	4.350	1.250	225	250	9.612
MC 39.10 A	3.840	3.900	1.000	1.500	4.350	1.500	225	250	10.033
MC 39.12 A	4.620	3.900	1.200	1.500	4.350	1.700	225	250	10.369
MC 39.15 A	5.790	3.900	1.500	1.500	4.350	2.000	225	250	10.873
MC 39.18 A	6.960	3.900	1.800	1.500	4.350	2.300	225	250	11.378
MC 39.21 A	8.130	3.900	2.100	1.500	4.350	2.600	225	250	11.882
MC 42.07 A	3.090	4.200	0.750	1.500	4.650	1.250	225	250	10.173

Reference	Eff. Area	Internal Dimensions			External Dimensions		Normal Thickness		Approx Weight
* Stock Item	m.sq	Width m	Height m	Length m	Width m	Height m	Walls mm	Slabs mm	Tonnes
MC 42.10 A	4.140	4.200	1.000	1.500	4.650	1.500	225	250	10.593
MC 42.12 A	4.980	4.200	1.200	1.500	4.650	1.700	225	250	10.929
MC 42.15 A	6.240	4.200	1.500	1.500	4.650	2.000	225	250	11.434
MC 42.18 A	7.500	4.200	1.800	1.500	4.650	2.300	225	250	11.938
MC 42.21 A	8.760	4.200	2.100	1.500	4.650	2.600	225	250	12.443

Table Notes:

A Adjustable size mould range -

Details of splays:

- MC 10.05 to MC 10.07 : 150 * 50mm
- MC 12.05 to MC 13.10 incl : 225 * 75mm
- MC 15.07 upwards : 300 * 100mm

Typical Box Culvert Images



Manhole / Integrated Ladder System

CPM, in conjunction with Caswick, the market leading manhole step producer has developed an Integrated Manhole Ladder system. This innovative product has been designed to provide safe access and egress to precast concrete manholes, caisson shafts and inspection chambers. A range of rungs are pre-fitted into the chamber to make the installation of the ladder quick, cost effective, reliable and safer than conventional ladders.

The system has WRc approval and meets the essential requirements of existing and new design codes in terms of dimensions and performance.



System advantages

- The integrated manhole ladder system has the innovative ladder rungs pre-fitted into the chamber rings therefore the system is delivered to site partly pre-installed
- The chamber rings are then installed in the conventional way, ensuring that the ladder steps are inline
- The Integrated Manhole Ladder System has been granted WRc approval

Ease of Installation

- The Ladder Rungs are pre-fitted at 250mm centres into the chamber sections, leaving only the Stringer, Locating Bracket and End Caps to fit
- Minimal access to a confined space to fit ladder stringers
- No lifting, drilling or temporary access required to chamber

Flexibility

- The incorporation of the Ladder Rung in the manhole automatically takes account of the variation in depth to design
- No bespoke ladder needs to be surveyed, ordered or manufactured
- No equipment hire compared to fitting traditional galvanised steel ladder

Safety

- The polypropylene polymer encapsulation gives high visibility and no sharp edges
- The rung has a tread pattern to give good slip resistance
- The stringer has a circular cross section designed to give a secure hand grip unlike a conventional ladder which is normally too large to safely hold on to

Quality

- Ladder rungs are kitemarked to BS EN 13101
- Ladder rungs are reinforced with high tensile steel tube
- The ancillary fitting brackets are made from stainless steel Grade 304 or 316

Durability and Strength

- Ladder rungs are pre-fitted to ensure factory controlled performance and are pull out and deflection tested to BS5911 part 3
- The chemical resistance of polypropylene can be considered equivalent to Grade 316 stainless steel

Product Standards

- The system has been designed and manufactured in accordance with the requirements specified in: BS EN 13101 Steps for underground man entry chambers / BS EN 14396 Fixed ladders for manholes

Catch-pit/silt trap chamber systems

CPM has developed a range of off-site solution catchpit and silt trap manholes so why spend days constructing an in-situ catch-pit manhole on site when one-piece chambers are available now and can be installed within hours, not days!

The reinforced watertight one-piece structures offer greater design flexibility with a range of cored or pre-formed holes/cut-outs for inlet/outlet holes which come complete with seals CPM modular catchpits save money and time as they are built under factory conditions to your specification ensuring dimensional correctness as well as a high quality finish.

Design options include:

- 1050mm to 3000mm standard tongue and groove complete with a cast-in reinforced base
- 1200mm, 1500mm and 1800mm sealed manhole joint complete with cast-in reinforced base
- Pipe inlet/outlet diameters covered by system 100mm to 1800mm

Benefits of using a CPM catchpit and silt trap

- Reduced costs in construction time and on-site personnel
- Sump depths to suit design requirements
- Accommodates uPVC, twinwall, clay, ductile iron and concrete
- Increased Health and Safety benefits as it reduces on-site construction
- Reduces wet trades for manhole construction
- Product is made and tested under factory conditions
- Eliminates extra transport and material wastage used with on-site construction methods
- Chamber bases are Kitemarked
- 1050mm unit weighs less than one tonne
- Bespoke design to suit customer requirements
- Standard tongue and groove joints
- Greatly reduced installation time on site
- None or minimal on-site fabrication required



Preformed Manholes

CPM has developed an off-site large modular manhole system that is designed to speed up the installation of the manhole whilst providing a safe working environment for personnel working within the manhole.

The benefits of the wide wall section include:

- An established and proven product range that is Quality Assured
- Wide wall products are supplied with a Butyl sealant which removes the need for a concrete surround
- The chamber is supplied with a reinforced cast-in base
- The chamber system provides preformed inlet and outlet holes to suit pipe requirements
- The chambers are manufactured in fixed steel moulds that give a superior dimensional accuracy
- Wide wall chambers have an inherent structural concrete strength with a 120 year design life
- Chamber units are supplied with cast-in brackets for a lifting loop system
- AutoCAD drawings can be provided
- Kitemarked product range

Product specifications include:

- All chamber sections are manufactured to the requirements of BS5911-3, 2100mm, 2400mm, 2700 and 3000mm are kitemarked.
- The base chamber is manufactured with a 200mm deep; grade C40, reinforced concrete base dowed into the chamber unit. Concrete has a minimum cover to reinforcement of 30mm.
- The inlets and outlets are either pre-scored, pre-formed or cored holes (depending on size) to suit the customer's requirements.
- Cover slabs are manufactured to the requirements of BS EN 1917:2002 and BS 5911-3:2010

Nominal Diameter	Outside Diameter	Weight per 500mm	Weight per 750mm	Weight per 1000mm
(mm)	(mm)	Depth	Depth	Depth
2100	2350	1070	1605	2140
2400	2680	1370	2055	2740
2700	3000	1700	2550	3400
3000	3330	2070	3105	4140
3660	4030	2650	3980	5300
4000	4400	N/A	4770	6360



For an installation sequence please see our website: www.cpm-group.com

L Shape Retaining Walls

CPM L Shape precast concrete walling makes wall units easier to use as both faces of the unit are vertical and there are only two thicknesses of wall for the complete range.

Accessories

- Corner filler unit with straps and cleats
- Lifting and handling equipment

CPM L shape retaining wall units are manufactured from C40/50 concrete with 50mm nominal cover to reinforcement.

They can be used in very severe exposure conditions as defined in BS 8110 Part 1 and severe exposure conditions as defined in BS 5400 Part 4. Stock units are suitable for loading from either side, with maximum loading from a level fill with a density of 19kN/m³ and 10kN/m² live load surcharge or sloped up at max. 30° to an equivalent height to the wall. A qualified engineer should check the foundation and wall stability.

Holes (32 dia) are provided to connect units with insitu foundation to provide stability against sliding and overturning. Holes in the wall stem provide lift points, corner filler strap cleat fixings and weep holes.

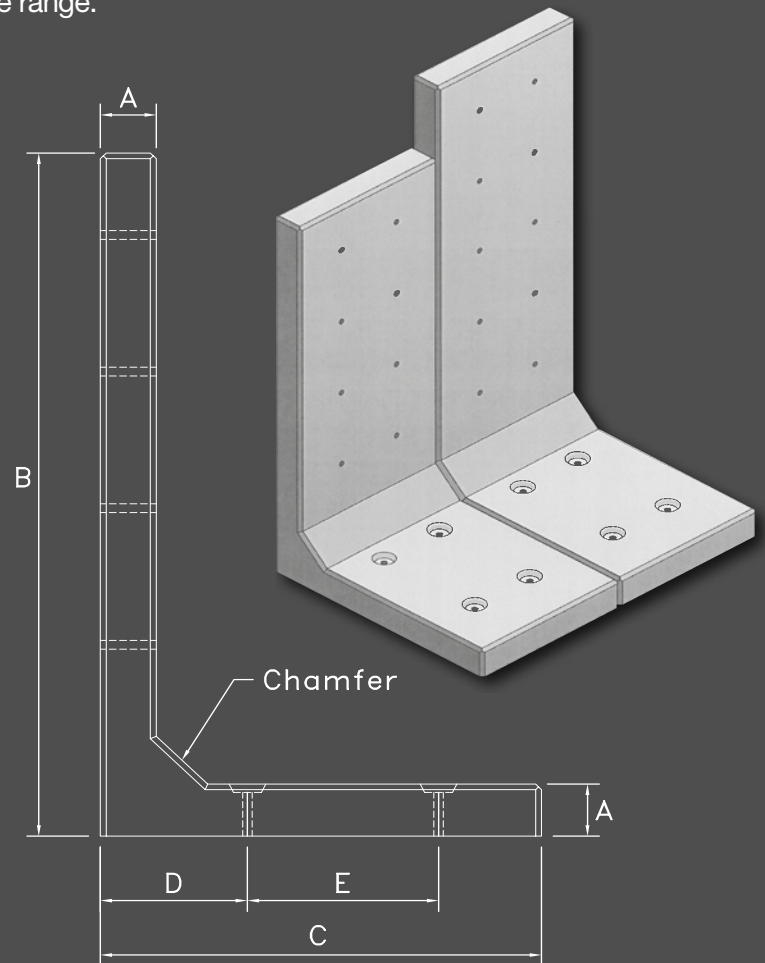

Dimensions (mm)							
Height (mm)	A	B	C	D	E	Chamfer	Weight (kg)
1000	120	1000	650	400		135 x 135	470
1500	120	1500	650	400		135 x 135	626
2000	190	2000	1000	500		135 x 175	1350
2500	190	2500	1500	500	650	175 x 175	1810
3000	190	3000	1500	500	650	175 x 175	2040

*Bespoke only

Complete UK Coverage

HEAD OFFICE / ENGLAND / WALES SALES AND SOUTHERN WORKS

CPM Group Ltd, Mells Road, Mells,
Nr Frome, Somerset, BA11 3PD
Tel: 01179 812791 Fax: 01179 814511

NORTHERN WORKS

CPM Group Ltd, Pollington, Goole,
East Riding of Yorkshire, DN14 0DU
Tel: 01405 860591 Fax: 01405 863606

SCOTLAND SALES

CPM Group Ltd, 101 Main Street, Newmains,
Wishaw, Lanarkshire, ML2 9BG
Tel: 01698 386922 Fax: 01698 387167

PERFECT MANHOLE SALES

CPM Group Ltd, Barnfields, Leek,
Staffordshire, ST13 5QG
Tel: 01538 380500 Fax: 01538 380510

TECHNICAL OFFICES

CPM Group Ltd, CPM House,
Heath Mill Road, Wombourne,
Staffordshire, WV5 8AP
Tel: 01902 356220 Fax: 01902 356221



sales@cpm-group.com
www.cpm-group.com