

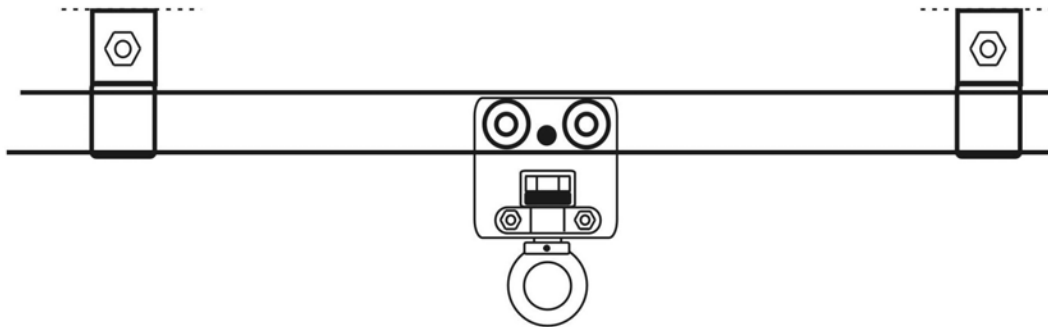

Personal Safety System NIKO PSS 25

Horizontal Security System with
track arrangement 25.000



Assembly and Operation Instructions

PSS 25 03/04



TÜV Tested in Austria
EN 795/Class D
Test. cert. No. TÜV-A- MHF/FÖT-1/04/FT04-026



Contents

1 General Instructions

Manufacturer
Department
1.1. Regulations

2 Safety Instructions

2.1. Regulations of use

3 Product Description

3.1. Parts
3.2. Standards
3.3. Construction

4 System Components

4.1. Use of parts
4.2. Track attachments
4.3. Moving apparatus
4.4. Coupling & Stopper
4.5. Track
4.6. Assembly regulation

5 Safety Instructions

6 Servicing

6.1. Checklist



1 General Instructions

Manufacturer

<u>Greece</u>	<u>U.K.</u>	<u>Austria</u>
Helm Hellas S.A PO Box 209 20100 Korinthos Tel: 0030-27410-85803 Fax: 0030-27410-25368 e-mail: helmhellas@hotmail.com	NIKO Limited Kineton Road Industrial Estate CV47 OFB Southam Tel: 0044-19268-1311 Fax: 0044-19268 – 15599 e-mail: Sales@niko-ltd.co.uk	NIKO Vertriebs gmbh Hainsfeldstraße 3 A-2564 Weissenbach Tel: 0043-2674-81005 Fax: 0043-2674-81006 e-mail: nikobeschlag@aon.at

1.1 Regulations

The personal safety system NIKO PSS 25 is only to be used for the safety of attached persons.

The system does not replace personal safety harnesses (PSA)

Rolling Apparatus Type 25.T10P are only to be used for materials. Maximum load 100kg.



2 Safety Instructions

2.1 Regulations of Use

1 person permitted to each reel.

Each safety reel must only be used in combination with a personal safety harness.

Dampers are to be used.

- a) Safety harnesses according to EN 355 are to be used during use.
- b) The compulsory fall and catch distances must be paid attention to.
The manufacturers regulations must be observed for use.
- c) **Distance to collision:**
Is the least space necessary to ensure that a secured person, in the case of a fall, falls onto no obstacles. The fall height must always be reduced to a minimum. The calculation of the fall height depends on the system used:
Means of connection, dampers, distortion and safety belt.
Minimum distance from the impact point (incl. body height) + 1m to floor or obstacle.

!!!Pay attention to wall ledges, mouldings or other construction obstacles!!!



3 Product Description

3.1 Parts

Horizontal running track system with detachable coupling for wall or ceiling fastening as well as fastening to a steel girder above.

Internally running reels each with 4 ball bearing reels and a safety bolt which prevents the reel falling due to axle or bearing break.

The running track system can be assembled lineally or follow a given track, allowed through several curves. By dividing the track in several directions - track switches are assembled which can lead into one or more different tracks. The running reels are available in two levels of performance.

Reel Type T40 with vertical swivel vice 360° and ring nuts DIN 582.

Reel Type T20 with ball bearing oscillation and pivoted axle through an angle of max. 15°. Track stoppers of Type 25.X01 are screwed on the open end of the track.

Switch systems are delivered either with manual or automatically changing sliders.

The operation can be carried out manually or by chain pull.

3.2 Standards

The parts comply with EN 795 class D.

3.3 Construction

The track system is constructed for vertical assembly. Linear tracks or one following a course.

Fastening: The tracks are attached to steel girders or masonry with coupling or with angle support. The fastening distances are depicted at 4.1. It is permitted to exceed this distance by max. 10% (through construction necessity)

Warning: Each fastening point must be capable of holding a load of 35kn.

At assembly the foundations must be checked and the holding strength of the fastening points must be verified through protocol. At assembly onto steel constructions- screws of DIN 933 M16 (8.8) must be used.

The free standing tracks are allowed to hang max. 300mm over the last fastening coupling. If these distances are exceeded then additional fastening couplings are to be built.



Free standing tracks and track joints are to be separated by at least a full section. See 4.6 assembly regulations.

At assembly of curves, a load-bearing coupling is to be put in the middle of each curve. Instruction for the exact positioning of the coupling is at 4.1.1, which is to be followed. In the case of tracks, which are slanting - suitable supporting devices must be assembled so that the reel runs over no brake mechanisms. This can only take place with further discussion with the manufacturer, or more specifically after a calculation by a control body.

(All non-horizontal tracks must need a special examination)

The switches are screwed into the system with connecting coupling and are to be hung immediately before the connecting coupling. Track stoppers are to be used on open tracks, which must be secured against shifting horizontally with a steel screw DIN 933 M8x80.

4 System Components

4.1 Use of Parts

Straight and curved track parts

Materials for accessories and components

Steel quality St37 2 according to DIN 17100

Ball bearing material AISI 1015, Surface hardness 58-62 HRC

Surface galvanised yellow chromed

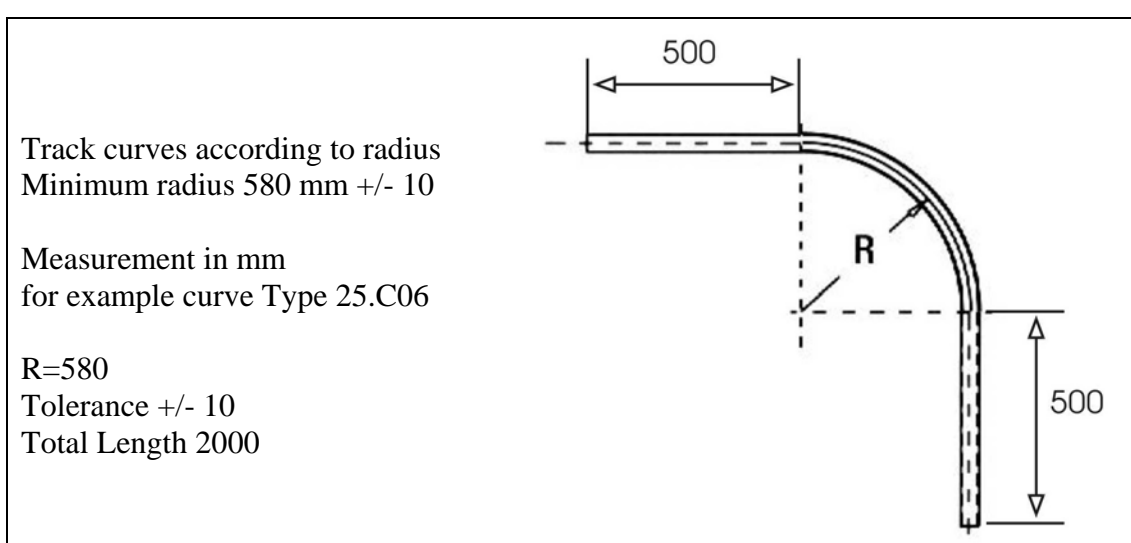
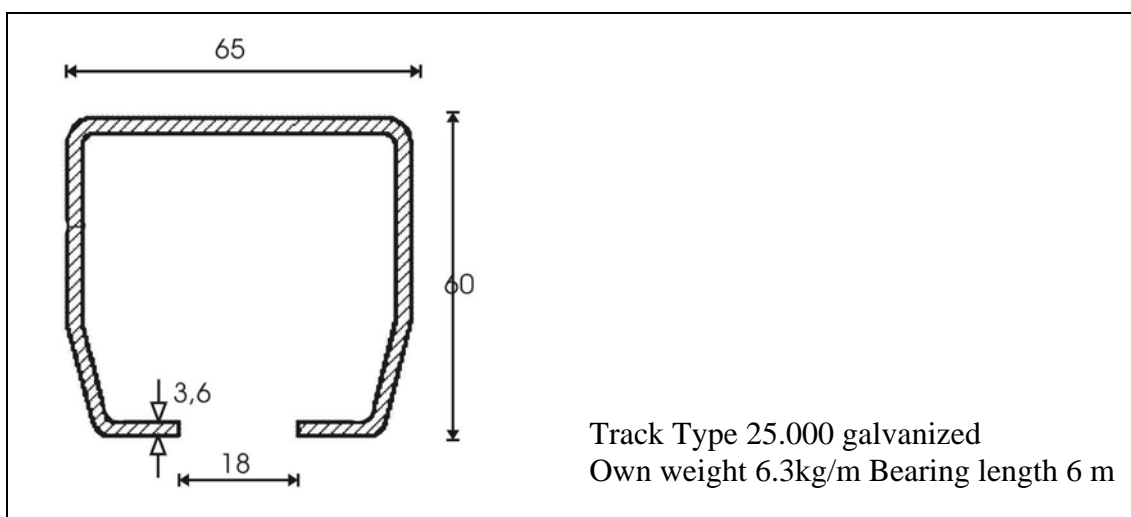

4.2 Track Attachments

Track fastening

! After a fall case the wall coupling and dowels are to be changed!

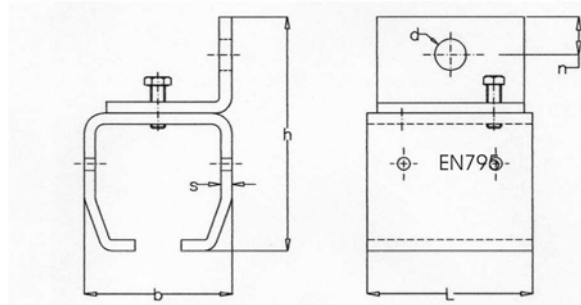

NIKO Profile No.	25.000
Wall support bracket No.	25.B01
Dimension b (mm)	80
h	125
L	90
n	18
d	17 ϕ
S	6

Wall coupling Type 25.B01P

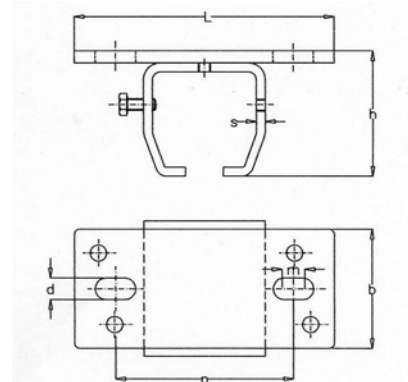

NIKO Profile No.	25.000
Ceiling support bracket No.	25.B02
Dimension b (mm)	80
h	83
L	170
n	124
d	17
m	10
s	6

Ceiling coupling Type 25.B02

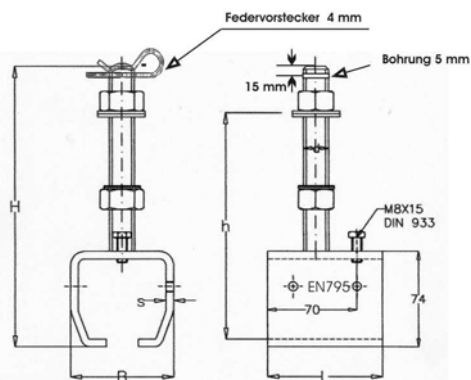

NIKO Profile No.	25.000
Adjustable bracket No.	25.B04
Dimension B (mm)	82
H	215
L	90
h	140 ²⁵
d	M20
S	6

Height adjustable coupling type 25.B04P

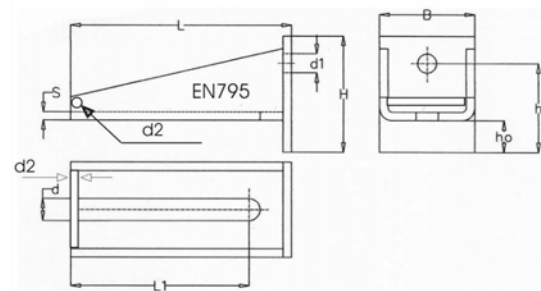

NIKO Profile No.	26.000
Double adjustable wall bracket No.	26.B06
Dimension B (mm)	90
H	110
h	85
ho	31
L	208
L1	168
S	8
d	21
d1	ϕ 18
d2	8 mm

Angle support (to coupling) type 26.B06P

4.3 Moving apparatus

Material Carrier Type 25.T10P (not for persons)

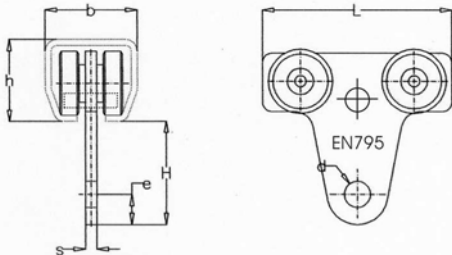

NIKO Profile No.	25.000
4-Wheel trolley with hole No.	25.T10
SWL Kg	200
Dimension H (mm)	62
L	120
h	60.0
b	65.0
d	18
e	20
s	10

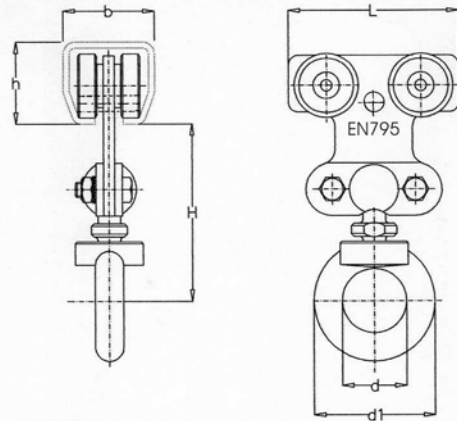

NIKO Profile No.	25.000
4-Wheel trolley with a rotating eye nut DIN582 No.	25.T20
SWL Kg	100
Dimension H (mm)	122
h	60
b	65
L	110
d	40
d1	72

Person Carrier Type 25.T20P

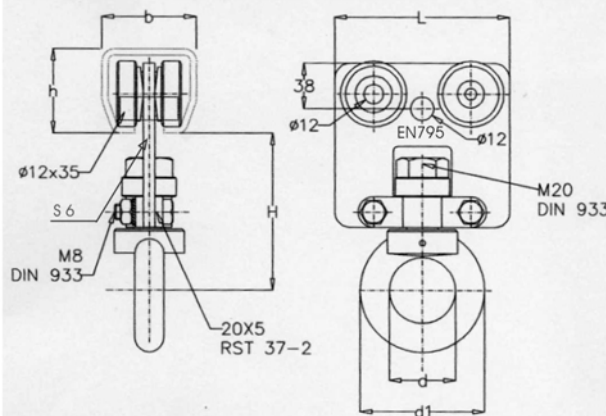

NIKO Profile No.	25.000
Wheel hanger with rotating eye nut DIN 582	25.T40
SWL Kg	100
Dimension H (mm)	93
h	60
b	65
L	110
d	40
d1	72

Person Carrier Type 25.T40P

4.4 Coupling and Stopper

Connecting coupling 25.B49

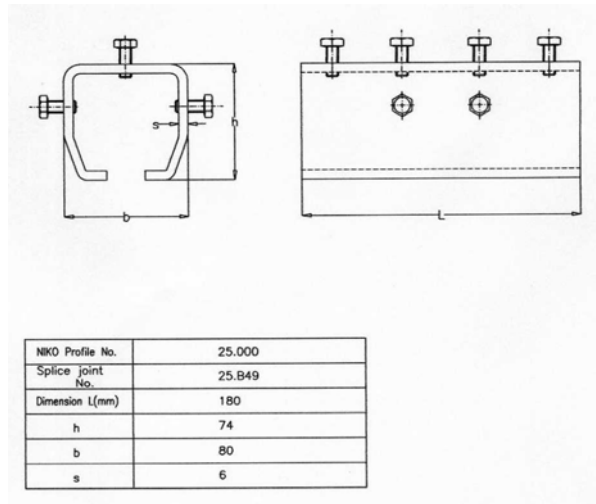

Track Stopper Type 25.X01

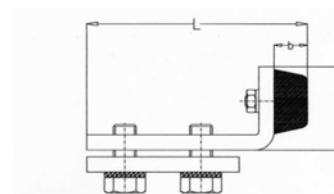

NIKO Profile No.	25.000
Track end stop No.	25.X01
Dimension L (mm)	122
h	45
b	22

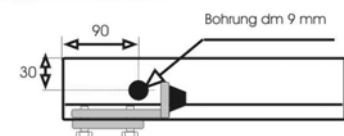

Positioning of safety screw M8x80.

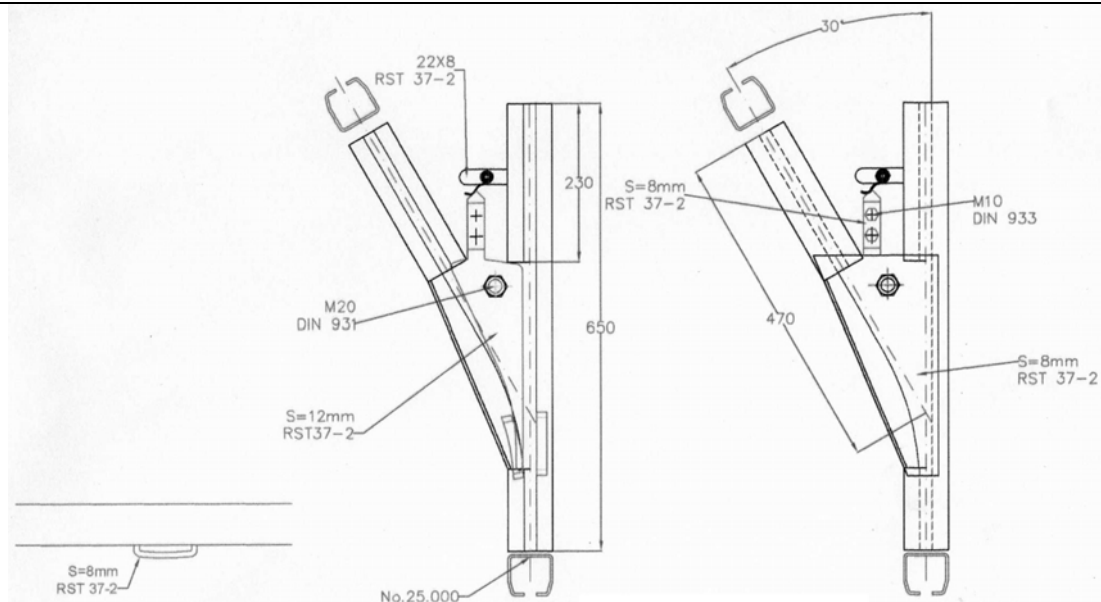

Simple splitting switches
 Type 25.A05 left direction.
 Type.A05 right direction.

4.5 Track

On the track diagram below the attaching points can be seen.
 The given measurements are maximum distances and can be exceeded by max.10%
 View from above hung for example with ceiling coupling.

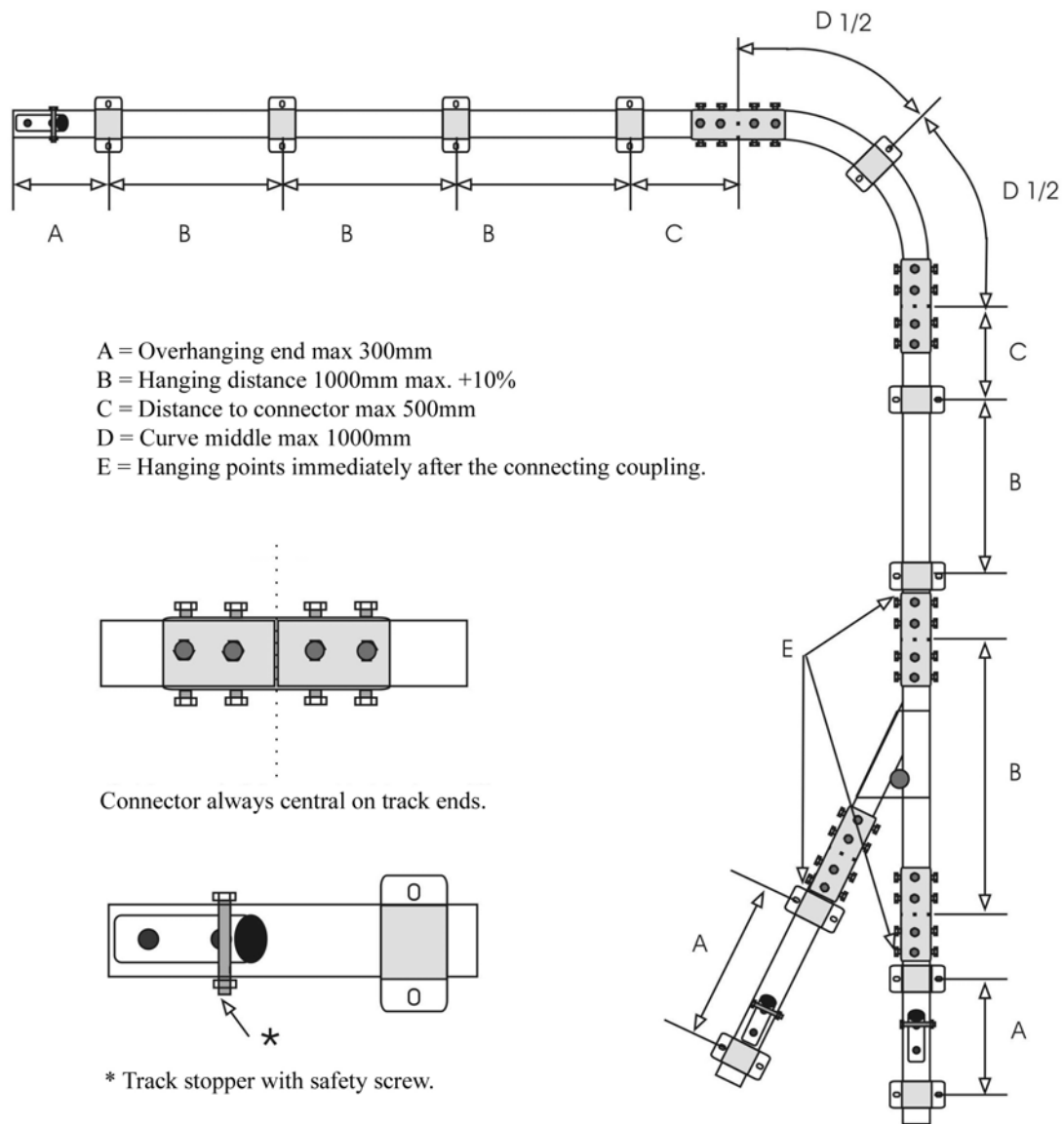

4.6 Assembly regulations

The tracks depicted below must be used according to the following procedures.

In the section of a overhanging end or in an edge section - no connecting coupling can be placed.

The same goes for track curves and switches.

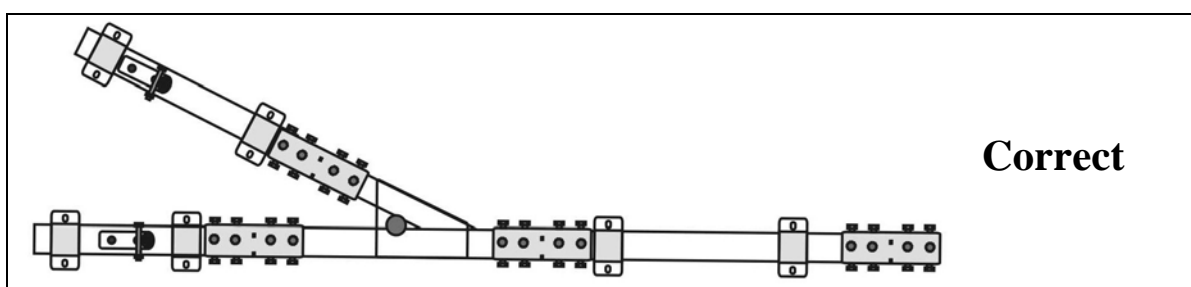
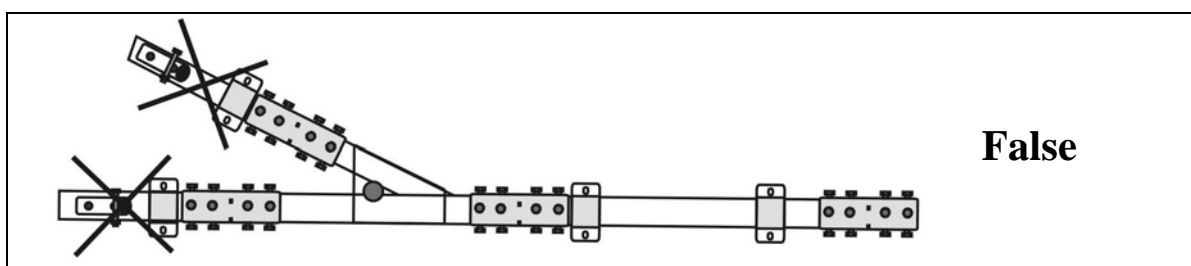
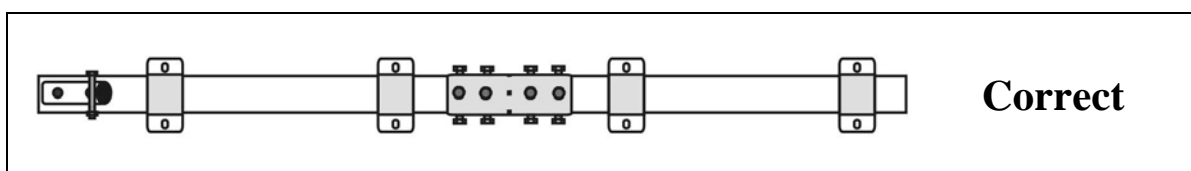
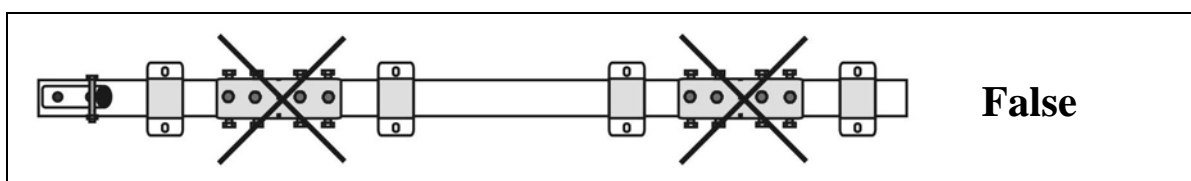

Special set-ups are only permitted after proceeding and written approval from an authorized body.



5 Safety Instructions

All fastening points must set up as is depicted in track 4.5. The manufacturer takes no responsibility for improper assembly. Be aware of correctly aligned assembly at track crossings. An optimal running quality can only be guaranteed by correct alignment of the parts. After assembly of the fastening coupling, the track is pushed into the coupling and fixed centrally to the security screws lying above. With poor fixing the tracks can slide out of the coupling due to one sided pressure. (Risk of falling)

Use of the track is exclusively permitted with Carrier Type 25.T20 and 25.T40.

The Carrier 25.T10 is only to be used for materials.

Persons and materials can not be carried in one Carrier.

6 Servicing

All Person safety systems NIKO PSS 25 are subject to repeated inspection. The inspection intervals depend on the use and demands placed on equipment. Fundamentally the following minimum intervals are to be kept.

In the case of security equipment in use 1 X monthly
Examination checklist 1 X year

In the case of security equipment in use 1 X weekly
Examination checklist 4 X year

In the case of security equipment in use daily (high wires, event arrangements)
Examination checklist 1 X week

After previous agreement, special equipment is to be dealt with separately by an authorized inspection office.



6.1 Examination Checklist PSS 25

All examinations of the equipment NIKO PSA 25 must be documented in this list.

Part	Tested:	Complies:	Comments
Coupling			
Screw joint attachment to construction below			
Fixing screw			
Observe yielding			
After fall (change coupling and dowels)			
Track			
Corrosion			
Material wear			
Track crossings			
Fixings			
Track connections			
Positioning			
Fixings			
Track curves			
Corrosion			
Material wear			
Track crossings			
Fixings			
Switch system			
Corrosion			
Axle screw wear and play			
Switch splitting function and wear			
Switch rest function and connection			
Wear of split support frame position			
Crossing and and position of the connections			
Wear of connections			
Track stopper			
Wear and position			
Security screw positioning			
Rubber buffer			
Carrier			
Running quality			
Bearing play			
Position of carrying screws			
Position of clip screws			
Wear on ring coupling			
Wear on carrier body			
Corrosion			
Other			

Equipment examined on:

Permitted for use: Yes ____ No ____

Examiner:



Personal Safety System PSS 25

Mechanism tested according to EN 795 Class D
Test. cert. No. TÜV-A- MHF/FÖT-1/04/FT04-026

Use of the system is permitted only by instructed persons.
Maximum loading weight respectively 100kg. & 1 load bearer.
Loads and persons run along separate tracks.
Pay attention to the operation instructions.

Permitted for ___ Persons

NIKO Vertriebsgesellschaft m.bH
Hainfelderstraße 3, A-2564 Weissenbach
Tel. : 0043-2674-81005

Personal Safety System PSS 25

Test. cert. No. TÜV-A- MHF/FÖT-1/04/FT04-026

Built in:

System No.:

Inspection Office:

Next examination due:

NIKO Vertriebsgesellschaft m.bH
Hainfelderstraße 3, A-2564 Weissenbach
Tel. : 0043-2674-81005