

Uniclass	EPIC
L8247	Q247
CI/SfB	
(74.8)	X (U31)



Baby Changing Units



the
MH42



the
MV64



the
MC75

...Shaped for the Future

the **MH42** Horizontal Baby Changing Unit

The MH42 horizontal, fold-down baby changing unit combines innovative design with the latest safety features. This compact, stylish unit will enhance any washroom.



Colour option shown: White Fleck

- New, contoured contemporary design
- Unique hinge construction eliminates finger traps
- Choice of colour to suit any project
- Extra deep sides increase safety and eliminate the need for straps
- Withstands static loads in excess of 100Kgs
- Hygienic, easy-clean surface



MH42 Colour Options



White Fleck



Oatmeal

Fully Compliant with
BS EN 12221: 2008 ✓

the **MH42** **MAGRINI**
Meeting Tomorrow's Standards Today

Key Features



The unique hinge construction eliminates finger traps even during opening and closing. The hinge rotates within the enclosed moulding eliminating exposure to moving parts.



Superior integral strength, with stainless steel reinforced hinge, withstands static loads in excess of 100Kgs. Strong enough even for a baby elephant!



Extra deep barriers provide natural protection. This intrinsic safety feature eliminates the uncertainty involved in the use of straps. Easy to install with Magrini fixing kit.

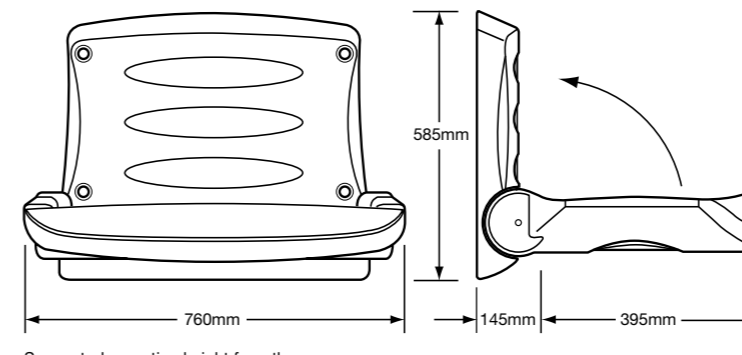

Suggested mounting height from the floor to the base of the unit is 730mm

SAFETY STANDARDS

The Magrini MH42 is fully compliant with and independently tested to BS EN 12221:2008.

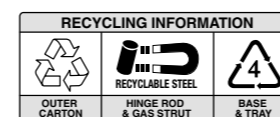

Designed and
Manufactured in the UK

Specification Clause - Manufacturer: Magrini Ltd., Tel: 01543 375311 Fax: 01543 361172. Horizontal baby changing unit, Ref: MH42. Size: 760mm (width), 585mm (height), 145mm (closed depth), 540mm (open depth). Material: MDPE with enclosed stainless steel reinforced hinge and gas strut closing mechanism. Colour option: Oatmeal or White Fleck. Installation kit as supplied by manufacturer. Fully compliant with BS EN 12221:2008



the **MV64** Vertical Baby Changing Unit

The space saving MV64 vertical, fold-down baby changing unit fits where wall space is limited. It allows stylish nappy changing facilities to be provided in even the smallest of washrooms.



Colour option shown: Oatmeal

- New, contoured contemporary design
- Unique hinge construction eliminates finger traps
- Choice of colour to enhance any project
- Extra deep sides increase safety and eliminate the need for straps
- Withstands static loads in excess of 100Kgs
- Hygienic, easy-clean surface

Fully Compliant with
BS EN 12221: 2008 ✓



MV64 Colour Options



White Fleck



Oatmeal

the **MV64** **MAGRINI**
Meeting Tomorrow's Standards Today

Key Features



The unique hinge construction eliminates finger traps even during opening and closing. The hinge rotates within the enclosed moulding eliminating exposure to moving parts.



Superior integral strength, with stainless steel reinforced hinge, withstands static loads in excess of 100Kgs.



Extra deep barriers provide natural protection. This intrinsic safety feature eliminates the uncertainty involved in the use of straps. Easy to install with Magrini fixing kit.

Specification Clause - Manufacturer: Magrini Ltd., Tel: 01543 375311 Fax: 01543 361172. Vertical baby changing unit, Ref: MV64. Size: 545mm (width), 860mm (height), 140mm (closed depth), 830mm (open depth). Material: MDPE with enclosed stainless steel reinforced hinge and gas strut closing mechanism. Colour option: Oatmeal or White Fleck. Installation kit as supplied by manufacturer. Fully compliant with BS EN 12221:2008

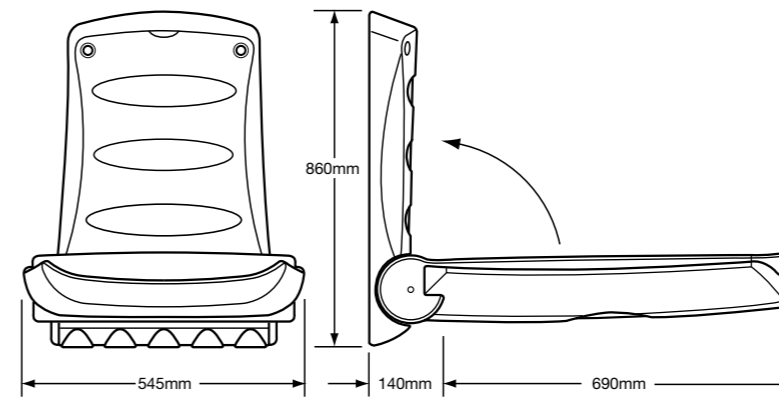

Suggested mounting height from the floor to the base of the unit is 730mm

SAFETY STANDARDS

The Magrini MV64 is fully compliant with and independently tested to BS EN 12221:2008.

RECYCLING INFORMATION		
OUTER CARTON	HINGE ROD & GAS STRUT	BASE & TRAY

Designed and
Manufactured in the UK



the MC75 Stainless Steel Baby Changing Unit

The MC75 stainless steel baby changing unit offers exceptional strength and durability. The all-metal construction is designed to withstand abuse and is ideal for unsupervised areas.



- Compact, fold-away design
- Stylish, brushed stainless steel finish
- Withstands static loads in excess of 100Kgs
- Ideal for use in areas where CCTV is not possible
- Graffiti and vandal resistant
- Exceptional fire resistance



Fully Compliant with
BS EN 12221: 2008 ✓

the MC75 **MAGRINI**
Meeting Tomorrow's Standards Today

Key Features



The enclosed metal hinge system eliminates finger traps even during opening and closing. The superior integral strength of this unit makes it ideal for unattended public washrooms.



The MC75 changing unit is constructed from stainless steel and aluminium which provide exceptional durability and fire resistance. The full length reinforced hinge withstands static loads of 100Kgs.

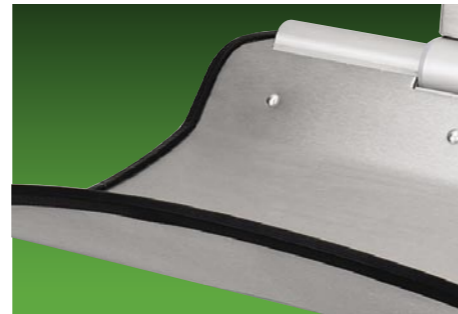

The specially configured barriers eliminate the uncertainty involved in the use of straps. The unit is easy to install with Magrini fixing kit and template.

Specification Clause - Manufacturer: Magrini Ltd., Tel: 01543 375311 Fax: 01543 361172. Wall mounted stainless steel baby changing unit, Ref: MC75. Size: 760mm (width), 650mm (height), 165mm (closed depth), 615mm (open depth). Material: Stainless steel 1.4301 DP2 with reinforced cast aluminium hinge system, dual hydro-pneumatic gas strut closing mechanism. Colour option: Stainless steel. Installation kit as supplied by manufacturer. Fully compliant with BS EN 12221:2008

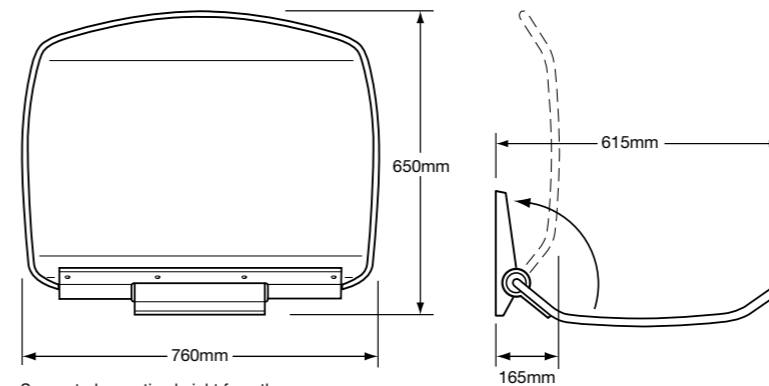

Suggested mounting height from the floor to the base of the unit is 740mm

SAFETY STANDARDS

The Magrini MC75 is fully compliant with and independently tested to BS EN 12221:2008.

RECYCLING INFORMATION		
OUTER CARTON	TRAY & COVER	HINGE ASSEMBLY

Designed and
Manufactured in the UK





MAGRINI

Baby Changing Units



the MH42



the MV64



the MC75

...Shaped for the Future

IMPORTANT NOTE ABOUT SAFETY STRAPS

There are a number of potential issues involved with the provision of straps:

- they are often not used
- they can be damaged or removed
- they may become unhygienic

In designing this range, Magrini have provided extra-deep barriers to eliminate the need for straps. Operators will benefit from reduced maintenance time and cost.

SAFETY STANDARDS

The Magrini MH42, MV64 & MC75 are fully compliant with and independently tested to BS EN 12221:2008.

The units must be fixed to the wall for safe use and are intended for children up to a maximum weight of 15Kgs.

Magrini reserves the right to make changes to prices and specifications without notice. Please confirm details at time of ordering.

MAGRINI

Magrini Limited, Unit 5, Maybrook Industrial Estate, Brownhills, Walsall WS8 7DG. Tel: 01543 375311 Fax: 01543 361172 Email: sales@magrini.co.uk Web: www.babychanging.co.uk

