

# Stainless Steel

Information on the range of stainless steel protection products including Wall Guards, Corner Guards, Corner and Floor Rails, Bollards and Door Protection.

# Stainless Steel Wall Guards



Gradus website:  
[www.gradusworld.com](http://www.gradusworld.com)

Gradus stainless steel wall guards provide a modern, hi-tech finish and are designed to protect walls from impact and abrasion caused by wheeled traffic. The hygienic nature of the wall guards make them ideal for use in environments such as food & pharmaceutical preparation and manufacturing facilities.

## Profiles:

- 304 grade Satin finish stainless steel
- 3 profile designs and various height options
- Comprise continuous stainless steel covers with fixing retainers
- Supplied cut to size to a maximum length of 2.5m (longer runs should be butt jointed on-site).
- End caps are formed during manufacture
- Interior use

## Information:

- For guidance on selection in line with HBN 00-10 & Mat 05 see pages 73 and 76
- Visit: [www.gradusworld.com](http://www.gradusworld.com) to download AutoCAD drawings, Gradus & NBS Specifications, Cleaning & Maintenance, Installation Guidelines and Health & Safety Data Sheets

# Stainless Steel Wall Guards

**SSWGA**

Product

Description



Shown with factory formed end cap

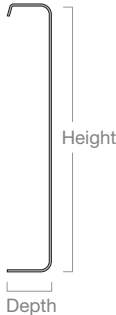

SSWGA	
Code	Depth x Height
SSWGA1	23mm x 73mm
SSWGA2	23mm x 101mm
SSWGA3	23mm x 152mm
SSWGA4	23mm x 195mm

**SSWGB**



Shown with factory formed end cap

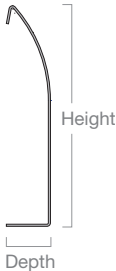

SSWGB	
Code	Depth x Height
SSWGB1	24mm x 125mm
SSWGB2	24mm x 200mm

**SSWGC**



Shown with factory formed end cap



SSWGC	
Code	Depth x Height
SSWGC1	25mm x 150mm
SSWGC2	25mm x 200mm

Profiles: Dimensions shown are nominal. Illustrations are not full size. Products subject to minor design alterations without notice.

# Stainless Steel Handrail



Gradus website:  
[www.gradusworld.com](http://www.gradusworld.com)

Gradus stainless steel handrail has been designed to provide a clean, modern finish for environments such as hospitality, leisure, commercial office, retail and healthcare. The hygienic nature of the handrail also makes it ideal for use in food & pharmaceutical preparation and manufacturing facilities.

## Profiles:

- 304 grade stainless steel – Satin or Polished finish
- Supplied in 3.0m lengths
- Comprise stainless steel handrail, brackets and matching accessories
- Can be curved – contact Gradus Contracts for radii information
- Interior use
- PVC-u handrail (pages 18 to 21) and timber handrail (pages 22 to 23) also available

## Information:

- Designed for use in horizontal circulation areas
- For guidance on selection in line with BS8300:2009 + A1:2010, Approved Document M of The Building Regulations 2000, HBN 00-10 and HBN 00-04 see pages 70 to 75
- Visit: [www.gradusworld.com](http://www.gradusworld.com) to download AutoCAD drawings, Gradus & NBS Specifications, Cleaning & Maintenance, Installation Guidelines and Health & Safety Data Sheets

# Stainless Steel Handrail

## SSHR45 Stainless Steel Handrail - typical example

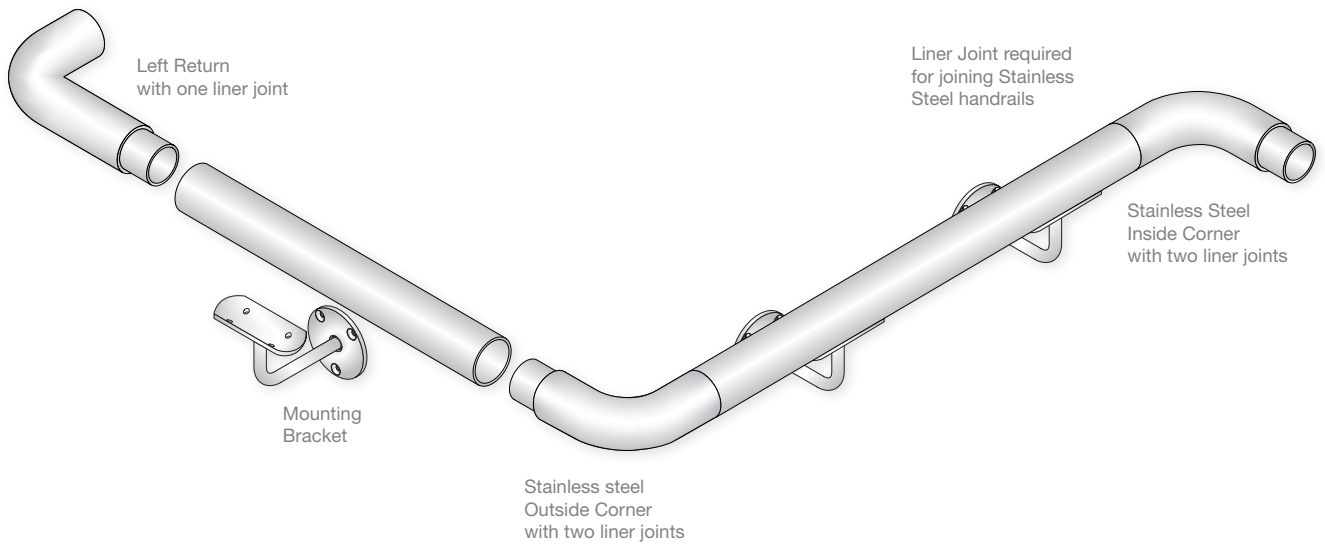

Designed to meet guidelines in BS8300:2009 + A1:2010 and Approved Document M (2004), with the aim to help specifiers and building owners meet their duties under the Equality Act 2010 (see pages 70 to 73)

- Handrail diameter: 45mm
- Bracket clearance: 50mm
- Distance from the wall: 67.5mm

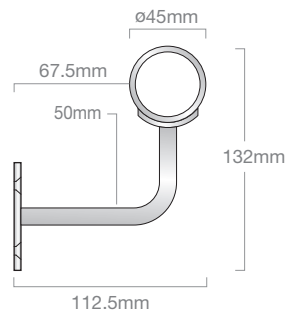

## SSHR45 Stainless Steel Handrail

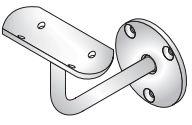
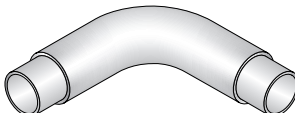
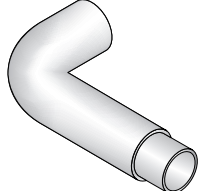

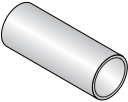
Mounting Bracket	Inside/Outside Corner 90°	Wall Return	Flat End Cap	Liner Joint
				
SSHR45/SBTKT	SSHR45/A90	SSHR45/RET	SSHR45/EC	SSHR45/SPLICE

Profiles: Dimensions shown are nominal. Illustrations are not full size. Products subject to minor design alterations without notice.

# Stainless Steel Floor Systems

Gradus stainless steel floor systems provide the ideal protection solution for surfaces that are not suitable for wall fixings, such as counters and glass partitions. Floor systems are specifically designed for keeping wheeled traffic away from the walls and can help create a sophisticated, unobtrusive finish for a modern design scheme.

## Floor Rails

- Ideal alternative to wall guards where wall fixings are not possible such as curtain walling or glass partitioning
- 304 grade stainless steel – Satin or Polished finish
- Comprises 51mm diameter rail with various pillar options and accessories
- Standard and heavy duty pillar and bracket options available for front and back of house applications
- Supplied in 3m lengths
- Can be curved – contact Gradus for radii information
- Interior use

Code	Description	Ø = Diameter
SSFR51	Stainless Steel Rail 51mm Ø	
SSFR51P/180/S*	Standard Pillar 180mm (h) - Chrome Plated Brass	
SSFR51P/230/S*	Standard Pillar 230mm (h) - Chrome Plated Brass	
SSFR51P/180/D*	Pillar with Diagonal Stay 180mm (h) - Chrome Plated Brass	
SSFR51P/230/D*	Pillar with Diagonal Stay 230mm (h) - Chrome Plated Brass	
SSFR51HD/230*	Heavy Duty Pillar 230mm (h) - Stainless Steel	
SSFR51FB/180	Straight Floor Bracket 180mm (h) - Satin Stainless Steel	
SSFR51SFB/180	Slanted Floor Bracket 180mm (h) - Satin Stainless Steel	
SSFR51A90	90° Corner - Internal & External	
SSFR51A135	135° Corner - Internal & External	
SSFR51SP	Joining Splice	
SSFR51EC	Flat End Cap	
SSFR51RET/180	Floor Return 180mm (h)	
SSFR51RET/230	Floor Return 230mm (h)	



Standard Pillar



Pillar with Diagonal Stay



Heavy Duty Pillar



Slanted Floor Bracket  
(straight version also available)

## Bollards

- Ideal alternative to wall guards where surface fixings are not suitable such as counters, refrigeration units, isolated equipment and doors in hold open position
- 2 profile options available in 2 heights
- 304 grade stainless steel – Satin or Polished finish
- Comprises bollard with base plate cover for concealed fixing
- Interior use

Code	Description	Ø = Diameter
SSP51/550	51mm Ø x 550mm (h)	
SSP51/1000	51mm Ø x 1000mm (h)	
SSP76/550	76mm Ø x 550mm (h)	
SSP76/1000	76mm Ø x 1000mm (h)	



# Stainless Steel Corner Protection

Gradus stainless steel corner protection offers durable and hygienic protection against damage caused by a wide range of wheeled traffic of varying heights, weights and projections.

## Corner Rails

- Allow wheeled traffic to be guided around corners without making contact with the substrate
- 2 profile options – Standard & Curved
- Supplied with wall fixing plates for secure fixing to the substrate
- 304 grade stainless steel – Satin or Polished finish
- Interior use

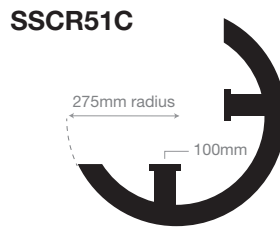
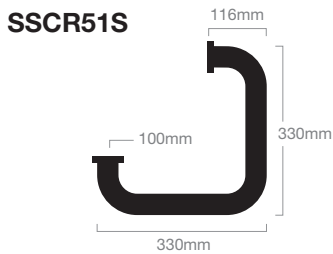

Standard - SSCR51S



Curved - SSCR51C

## Corner Guards

- Ideal for providing hygienic, durable protection for corners in areas such as kitchens, canteens and laboratories
- 304 grade Satin finish stainless steel - 1.5mm thick
- 2 profile options with up to 2 height options (special sizes, radii, angles and heights available on request)
- Can be supplied with pre-drilled counter sunk holes for screw fixing or without holes for adhesive fixing
- Interior use

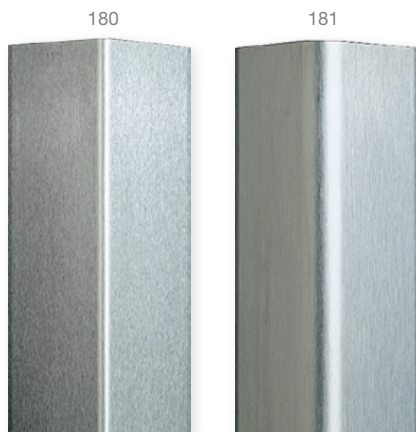

		<i>Height Options &amp; Codes</i>	
		1.22m	2.44m
<b>185</b>		Drilled	1854HOLE 1858HOLE
		Undrilled	1854CMT 1858CMT
<b>180</b>		Drilled	1804HOLE 1808HOLE
		Undrilled	1804CMT 1808CMT
<b>181</b>		Drilled	181HOLE n/a
		Undrilled	181CMT n/a

# Stainless Steel Door Protection

Gradus stainless steel door protection can help prevent damage and avoid the expense of repairs and replacement doors in areas such as loading bays, service corridors and kitchens which are exposed to frequent impact from heavy trolleys and other mobile equipment. The nature of stainless steel also makes these products ideal for use in environments requiring a hygienic finish such as food preparation areas and laboratories.

## Kickplates

- Offer severe duty impact protection to doors from wheeled traffic
- 304 grade Satin finish stainless steel – 1.5mm thick
- Can be supplied with or without pre-drilled counter sunk holes for screw or adhesive fixing
- Maximum size 1250mm x 2500mm (size to be specified at time of ordering)
- Interior use

Code	Description
130HOLE	Drilled
130CMT	Undrilled



## Door Edge Protectors

- Ideal for providing hygienic, durable protection for door edges in areas such as kitchens, canteens & laboratories
- 304 grade Satin finish stainless steel – 1.5mm thick
- Can be supplied with or without pre-drilled counter sunk holes for screw or adhesive fixing
- 'U' & 'L' shaped channels available in standard 965mm height – choice of 90° or 93° angles
- Interior use



			<i>Height &amp; Codes</i>
<b>190</b>		Drilled	965mm 190HOLE
		Undrilled	190CMT
<b>193</b>		Drilled	193HOLE
		Undrilled	193CMT
<b>290</b>		Drilled	290HOLE
		Undrilled	290CMT
<b>293</b>		Drilled	293HOLE
		Undrilled	293CMT



# Heavy Duty Rubber

Information on the range of heavy duty rubber protection products including wall guards and corner guards.

# Heavy Duty Rubber

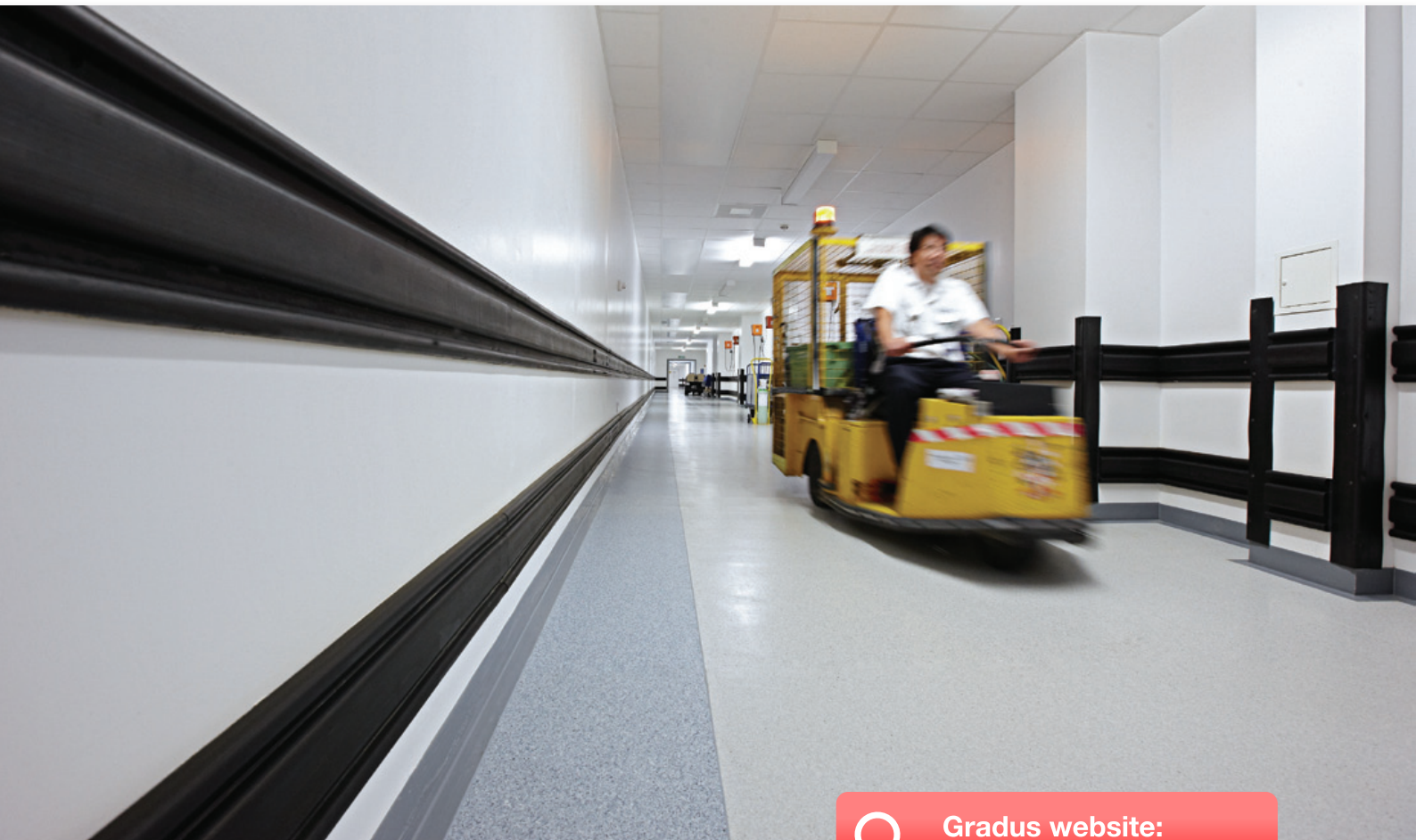

Gradus website:  
[www.gradusworld.com](http://www.gradusworld.com)

Gradus rubber wall and corner profiles have been developed to offer heavy duty protection against severe damage caused by wheeled traffic, such as trolleys and carts. Suitable for the protection of walls, corners and columns in areas such as manufacturing, warehousing & loading bays, back of house retail and hospital service corridors. Also suitable for use in car parks to offer effective protection solutions for vehicles and walls. The products absorb the effects of impact, thus minimising the extent of the damage.

## Profiles

- Black rubber
- 3 wall guard profiles & 1 corner guard option
- Supplied in 3m lengths
- Interior & exterior use

## Information:

- Usually installed onto solid backgrounds such as concrete, brick or brickwork. Surface preparation such as a timber base may be required for weaker substrates
- Visit: [www.gradusworld.com](http://www.gradusworld.com) to download: AutoCAD drawings, Gradus & NBS Specifications, Cleaning & Maintenance, Installation Guidelines and Health & Safety Data Sheets

# Heavy Duty Rubber

## Rubber Protection - typical example

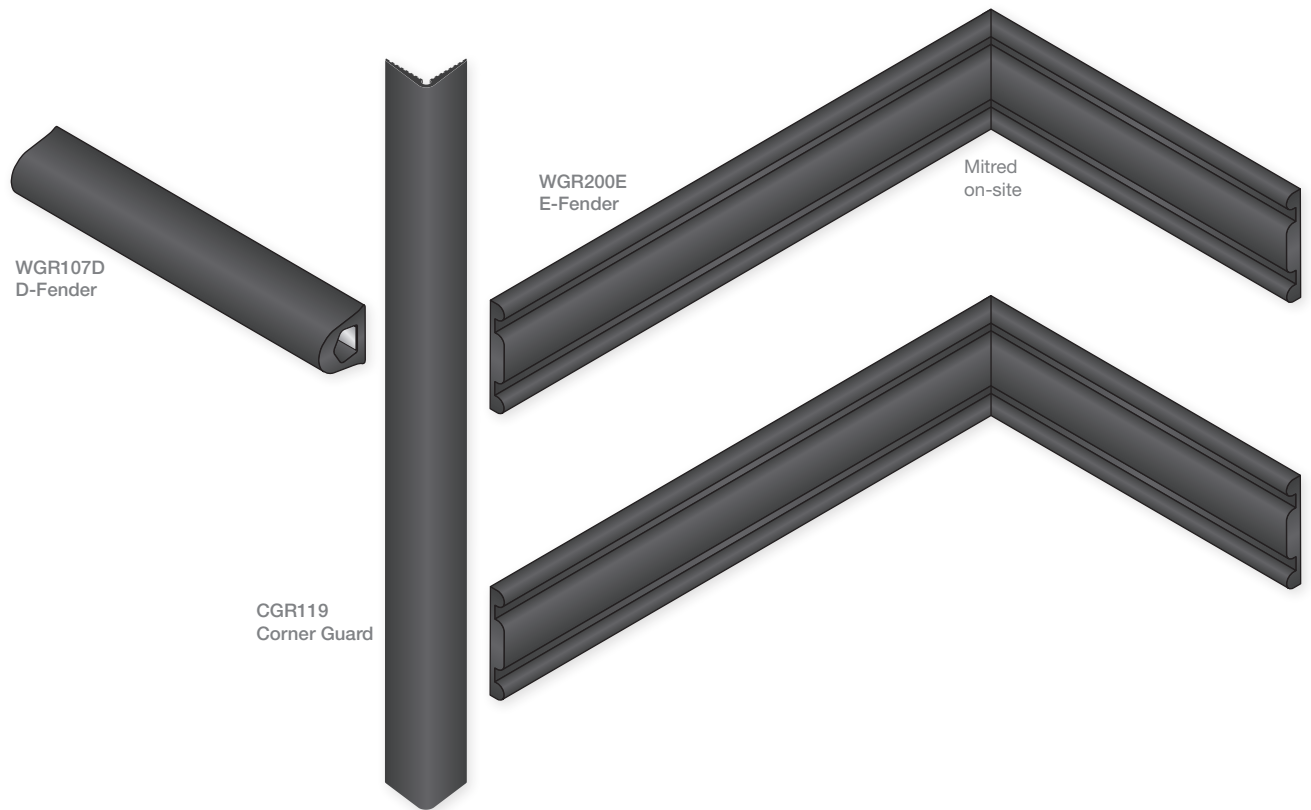

### WGR200E E-Fender



Can be curved - contact Gradus for radii information

### WGR150E E-Fender



Can be curved - contact Gradus for radii information

### WGR107D D-Fender



Galvanised steel fixing plate (supplied)

### CGR119 Corner Guard

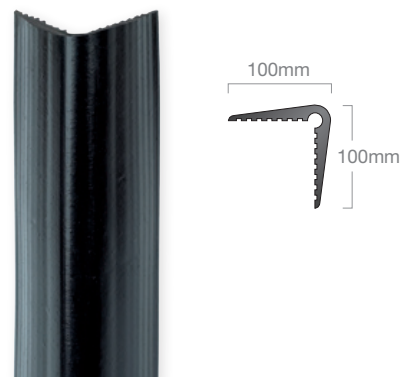



# Appendix

Specification guidelines on British Standards, Building Regulations, HBN 00-10, HBN 00-04 and Mat 05. Specification and ordering guidelines for handrails, combi-rails, Dual Rail and wall guards.

Product characteristics.

# Specification Guidelines

## The Building Regulations, British Standards and Construction Guidelines for specifying the appropriate Gradus product

Building Regulations and British Standards are designed to ensure the optimum specification of products through a combination of legislative requirements and guidance. The following extracts have been taken from the Building Regulations 2000, British Standard BS8300 + A1:2010, Health Building Note 00-10 and Health Building Note 00-04 and show how Gradus products can be used to help satisfy these requirements, and help achieve an inclusive environment in line with the Equality Act 2010. For further details on this or any other aspect of Building Regulations and Standards contact Gradus Technical Services on 01625 428922.

[Extracts from the Building Regulations](#)

### Building Regulations 2000 - Approved Document M “Access to and use of buildings” (Effective May 2004)

#### The Legal Requirement

Part M Access to and use of buildings  
Access and Use

M1. Reasonable provision shall be made for people to -

- a) gain access to : and
- b) use the building and its facilities

Gradus advice and recommendations for the Building Regulations - Approved Document M are detailed [in blue text](#).  
For further details contact Gradus Technical Services on 01625 428922.

#### Approved Document M

Approved documents are intended to provide guidance. Much of the guidance in the approved document is based on BS8300:2009+A1:2010. The guidance contained in Approved Document M is designed to indicate one way in which requirements may be met. There may be other equally satisfactory ways of meeting the requirements.

#### Entrance Lobbies

2.29 Entrance lobbies will satisfy Requirement M1 or M2 if:

- (h) Any columns, ducts and similar full height elements that project into the lobby by more than 100mm are protected by a visually contrasting guard rail.
- (h): [Protruding elements can be highlighted with products such as Sanparrel sheet, rubrails or Armaclad which can be formed around the element, additionally wall guards and corner guards can be used.](#)

#### Internal Doors

3.8.1 The presence of doors, whether open or closed, should be apparent to visually impaired people through the careful choice of colour and material for the door and its surroundings. For example, when a door is open, people with impaired sight should be able to identify the door opening within the wall, as well as the leading edge of the door.

3.10 Internal doors will satisfy Requirement M1 or M2 if:

- (e) All door opening furniture contrasts visually with the surface of the door.
- (f) The door frames contrast visually with the surrounding wall
- (g) The surface of the leading edge of any door that is not self-closing, or is likely to be held open, contrasts visually with the other door surfaces and its surroundings.

[Sanparrel kickplates, pushplates and door edge protectors, along with InPro door frame guards can be used to highlight and protect the door in a colour that contrasts to the door and wall.](#)

[Continued on the next page](#)

Source: Building Regulations - Access to and use of buildings - Approved Document M - 2004 Edition  
Crown Copyright material is reproduced with the permission of the Controller of HMSO and the Queen's Printer for Scotland.



Extracts from the Building Regulations

### Corridors and passageways

3.14 Corridors and passageways will satisfy Requirement M1 or M2 if:

- (a) Elements such as columns, radiators and fire hoses, do not project into the corridor, or where this is unavoidable, a means of directing people around them, such as a visually contrasting guard rail, is provided.
- (a): [Protruding elements, such as columns, can be highlighted with products such as Sanparrel sheet, rubrails, Armaclad, wall guards, handrails and corner guards.](#)

### Handrails to external stepped and ramped access

Note: Gradus handrails are not suitable for stepped and ramped access, however these guidelines are considered best practice guidelines for all types of handrails.  
Similar guidelines can also be found in BS8300:2009 + A1:2010 under 5.10 Handrail Design (see page 72).

### Design considerations

- 1.34 People who have physical difficulty in negotiating changes of level need the help of a handrail that can be gripped easily, is comfortable to touch and, preferably, provides good forearm support.  
[Made from PVC-u or timber, Gradus handrails have a comfortable grip with a smooth, safe finish which is not cold to the touch.](#)
- 1.35 Handrails should be spaced away from the wall and rigidly supported in a way that avoids impeding finger grip.  
[Gradus InPro 950 Handrail and Gradus 450 Timber Handrail are designed to meet the guidelines in BS8300:2009 + A1:2010 and Approved Document M \(2004\) with dimensions as stated \(see figures below\).](#)
- 1.37 Handrailing to external ramped and stepped access will satisfy Requirement M1 or M2 if:
  - (e) It contrasts visually with the background against which it is seen, without being highly reflective.
  - (e): [A wide range of colours is available, allowing a handrail to be selected in a colour that contrasts to the background.](#)
  - (f) Its surface is slip resistant and not cold to the touch.
  - (f): [Gradus handrails are either made from timber or have a textured PVC-u cover which makes them slip resistant and not cold to the touch.](#)
  - (g) It terminates in a way that reduces the risk of clothes being caught.
  - (g): [All Gradus handrails return to the wall, minimising the risk of snagging.](#)
  - (h) Its profile is either circular with a diameter of between 40 and 45mm, or oval preferably with a width of 50mm (see diagram 7).
  - (j) There is a clearance of at least 50mm between a cranked support and the underside of the handrail.
  - (k) There is a clearance of between 50 and 75mm between the handrail and any adjacent wall surface.
  - (h), (j) [Gradus InPro 950 Handrail and Gradus 450 Timber Handrail are designed to meet the guidelines in BS8300:2009 + A1:2010 & \(k\): and Approved Document M \(2004\) with dimensions as stated \(see figure below\).](#)

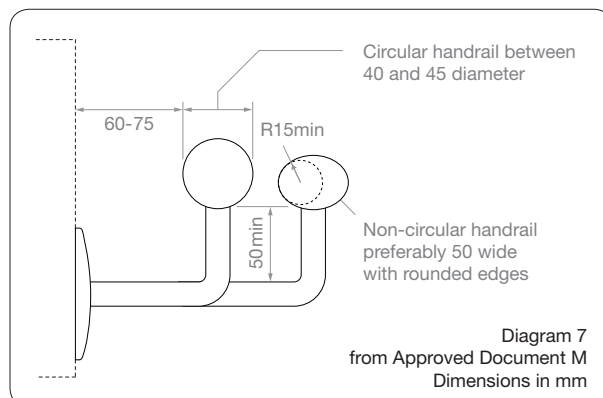

Source: Building Regulations - Access to and use of buildings - Approved Document M - 2004 Edition  
Crown Copyright material is reproduced with the permission of the Controller of HMSO and the Queen's Printer for Scotland.

# Specification Guidelines

## The Building Regulations, British Standards and Construction Guidelines for specifying the appropriate Gradus product

Extracts shown below show examples of best practice

### BS8300:2009+A1:2010

Incorporating amendment number 1

#### Design and Buildings and their approaches to meet the needs of disabled people - Code of Practice.

This standard provides guidance or good practice in the design of domestic and non-domestic buildings and their approaches so that they are convenient to use by disabled people. Gradus advice and recommendations for BS8300 : 2009 +A1: 2010 are detailed in blue text. For further details contact Gradus Technical Services on 01625 428922.

#### 5.10 Handrails

##### 5.10.2 Handrail Design

A handrail should be:

- (a) Easy and comfortable to grip with no sharp edges, but able to provide adequate resistance to hand slippage;
- (a): Made from PVC-u or timber, Gradus handrails have a comfortable grip with a safe finish.
- (b) Continuously graspable along its entire length without obstruction;
- (b): Gradus handrails are designed to provide a continuous uninterrupted grip, with accessories such as internal and external corners, allowing the handrail to navigate changes in direction.
- (c) Finished so as to provide visual contrast with the surroundings against which it is seen;
- (c): The wide range of colours available allows a handrail to be selected in a colour that contrasts with the wall finish.  
All Gradus handrail colours have been measured to provide Light Reflectance Values\* (LRVs) in order to provide the specifier with information to ensure that suitable contrast is achieved.

\*These values have been measured using the CIE Y value in accordance with BS8493:2008 + A1:2010

##### 5.10.3 Handrail dimensions and spacings

Any circular handrail should have a diameter of between 32mm and 50mm.

There should be a clearance of between 50mm and 75mm between a handrail and any adjacent wall surface, and any handrail support should meet the handrail, centrally, on its underside. The clearance between the bottom of the rail and any cranked support, or any continuous balustrade, should be at least 50mm to minimise the risk of the handrail supports interrupting the smooth running of a person's hand along the rail.

Gradus InPro 950 handrail and 450 Timber handrail are designed to meet the dimensions stated (see pages 20 to 21 & 22 to 23).

Note: Similar guidelines can also be found in The Building Regulations Approved Document M under 'Handrails to external stepped and ramped access' (see page 71).

Gradus handrails are not suitable for stepped and ramped access, however, these guidelines are considered best practice guidelines for all types of handrail.

#### 9 Surfaces and communication aids

##### 9.1 Surface finishes

The extent to which floor, wall, door and ceiling surfaces enable disabled people to find their bearings and maintain their independent use of a building is influenced by:

- The colour, pattern, light reflectance value (LRV) and texture of the surfaces;  
All Gradus products have an LRV to ensure that a suitable choice can be made to contrast between surfaces. For instance, kickplates and pushplates can be used to highlight the door. In addition, handrails that contrast to the background can provide support and direction.
- The treatment of components and finishing elements, such as doors, architraves, skirtings, handrails, etc. which define, or are contained within, these surfaces;  
Through the use of colour, Gradus products can be used to colour code different floors or departments, create wayfinding or highlight protruding elements such as columns.

Continued on the next page

#### 9.1.1 Visual Characteristics

Differences in LRV should be used to assess the degree of visual contrast between surfaces such as floors, walls, doors and ceilings and between key fittings/fixtures and surrounding surfaces.

All Gradus products have an LRV to ensure that a suitable choice can be made to contrast between surfaces. For instance, kickplates and pushplates can be selected to highlight the door, and handrails can be selected to contrast with the background.

#### 9.1.4 Wall Surfaces

Large, repeating patterns that incorporate bold, contrasting colours should not be used for the wall surfaces in parts of a building where visual acuity is critical.

Service outlets, light switches, and other functional elements on the surface of walls should be distinguishable from the wall, using visual and textural contrast.

Gradus Sanparrel protective PVC-u sheet is available in 30 solid colours in order for visual contrast and clarity to be achieved. This allows other functional elements on the wall surface to be highlighted using Light Reflectance Values to ensure suitable visual contrast.

Extracts from HBN 00-10 Performance requirements for building elements used in healthcare facilities

## HBN 00-10 (supersedes HTM 69)

This document outlines the policy and performance requirements for building elements used in healthcare facilities. These requirements are a set of essential standards of quality and safety that building elements must comply with. It supersedes Health Technical Memoranda 56, 60, 61, 64, 68 and 69.

Gradus advice and recommendations for HBN 00-10 are detailed in blue text.

For further details contact Gradus Technical Services on 01625 28922.

### Performance Requirements:

- Smooth, hard, seamless and impervious surfaces are required in clinical areas as they are easier to clean.
- Wall finishes should not comprise materials that promote or sustain the growth of fungi and micro organisms.
- Wall finishes are to be durable and able to withstand minor impacts without the need for additional wall protection.
- Wall finishes are to be impermeable and easily wiped over if necessary and not be physically affected or degraded by detergents and disinfectants.

Gradus Sanparrel offers an impermeable surface finish which is easy to clean and does not support the growth of bacteria or fungus. It is 1.5mm thick and through coloured in order to resist and conceal the effects of impact and abrasion.

### Requirements for impact protection:

Impact protection is intended to help reduce the incidence and severity of damage to walls and partitions in healthcare buildings so that their performance is maintained.

Protection fittings include:

- Handrails
- Crash rails
- Buffer rails
- Chair Rails
- Corner Guards
- Splayed Skirtings
- Protective Plates and sheeting
- Bed buffers

Gradus wall protection products are tested for impact resistance and are designed to absorb impact without damage to the substrate. The majority of profiles are modular in design, allowing damaged covers to be easily replaced without disruption.

Note:

This section does not cover the need for handrails as part of a protection system, as this is covered by the client's project-specific needs and the Equality Act 2010 (see also Health Building Note 00-04 – 'Circulation and communication spaces'). Nevertheless, this does not preclude the use of handrails as part of a protection system.

### Performance Requirements:

Materials and colours should comply with the requirements of the Equality Act 2010, where appropriate.

Gradus InPro wall protection profiles are available in 30 solid colours, all of which are measured for Light Reflectance Values, in order to ensure profiles can be selected to provide suitable visual contrast where required.

Materials for handrails are PVC-u or timber and offer a comfortable grip with a smooth, safe finish which is not cold to the touch.

Source: Department of Health Estates & Facilities Division: Core Elements – Health Building Note 00-10 Performance requirements for building elements used in healthcare facilities  
Crown copyright material is reproduced with the permission of the Controller of HMSO and Queen's Printer for Scotland

# Specification Guidelines

## The Building Regulations, British Standards and Construction Guidelines for specifying the appropriate Gradus product

Extracts from HBN 00-04 – ‘Circulation and communication spaces’

### HBN 00-04

Health Building Note 00-04 provides guidance on the design of circulation and communication spaces in hospitals and other healthcare buildings, including corridors, internal lobbies and stairs, and lifts. It also provides supporting information on doors and handrails.

Gradus advice and recommendations for HBN 00-04 are detailed in [blue text](#).  
For further details contact Gradus Technical Services on 01625 28922.

#### 2 General design and functional requirements

Visual and colour contrast

- 2.9 Contrasting handrails/crash rails may be fitted to act as navigation tools

The wide range of colours available allows a handrail to be selected in a colour that contrasts with the wall finish. All Gradus handrail colours have been measured to provide Light Reflectance Values\* (LRV) in order to provide the specifier with information to ensure that suitable contrast is achieved.

\*These values have been measured using the CIE Y value in accordance with BS8493:2008+A1:2010.

#### 3 Corridors

Handrails

- 3.29 Handrails should be fitted in main communication routes (that is, main corridors between departments) and in departmental departments as required. See specific departmental guidance for further information.

See [Gradus InPro handrails and combi-rails \(pages 18 to 21\)](#) and [Gradus InPro 3500/3500W Dual Rail \(pages 22 to 25\)](#)

#### 7 Handrails

Shape and size

- 7.3 Handrails should be easy to grasp; the size and shape should allow a firm but comfortable grip with the whole hand.
- 7.4 Handrails that are too small are uncomfortable and provide an unsatisfactory grip, whereas handrails that are too large are difficult to grip for people with weak or arthritic hands
- 7.5 A handrail that is round in cross section with a diameter of 40-45mm is recommended. Oval handrails with dimensions of 38mm x 50mm wide are acceptable. In both cases the longer dimension should be horizontal.
- 7.6 Handrails with large square or rectangular cross-section should be avoided.

All Gradus InPro handrails feature a round or oval grip. The Gradus InPro 950 handrail, 450 handrail and 3500/3500W Dual Rail feature grip diameters in line with the recommendations and the guidelines in BS8300:2009 + A1:2010 and Approved Document M (2004).

Shape and size

- 7.7 Handrails should allow enough space between the rail and the adjacent wall (or any other obstacle) for hands to pass without scraping knuckles and to aid those who want to use the rail as a support for the whole forearm.
- 7.8 A clearance of 60-75mm is recommended, as this allows the forearm to be rested on the rail without any danger of it getting trapped.

Gradus InPro 950 handrail, 450 handrail and 3500/3500W Dual Rail meet the recommended clearance dimension. Similar guidelines can also be found in BS8300:2009 + A1:2010 and Approved Document M (2004).

Provision in corridors

- 7.19 Handrails should return into recessed doorways and openings, but otherwise be continuous to aid navigation.

All Gradus InPro handrails are offered with a complete range of accessories to allow continuous runs around both internal and external corners and for safe returns to walls to take into account doorways and openings (see pages 18 to 25).

[Continued on the next page](#)

Source: Department of Health Estates & Facilities Division: Core Elements – Health Building Note 00-04: Circulation and communication spaces  
Crown copyright material is reproduced with the permission of the Controller of HMSO and Queen's Printer for Scotland

Handrails in association with wall protection

7.20 Where handrails and wall protectors are provided:

- a minimum vertical clearance of 50mm must be maintained between the handrail and wall protector (see Figure 30 and 31);  
[Gradus InPro 3500/3500W Dual rail is designed to meet the dimensions stated \(see pages 22 to 25\), incorporating a 50mm clearance between the handrail and wall guard element of the profile. All other Gradus handrails and wall guards are designed to work together and can be installed to the dimensions stated.](#)

7.22 Handrails should be:

- easily visible, that is, contrast visually with the surface to which they are fixed;  
[The wide range of colours available allows a handrail to be selected in a colour which contrasts with the wall finish \(see opposite – Visual and colour contrast\)](#)

- smooth and free from any abrasive elements;
- neither too cold nor too hot to the touch.

[Made from PVC-u or timber, Gradus handrails have a comfortable grip with a smooth, safe finish that is not cold or hot to the touch](#)

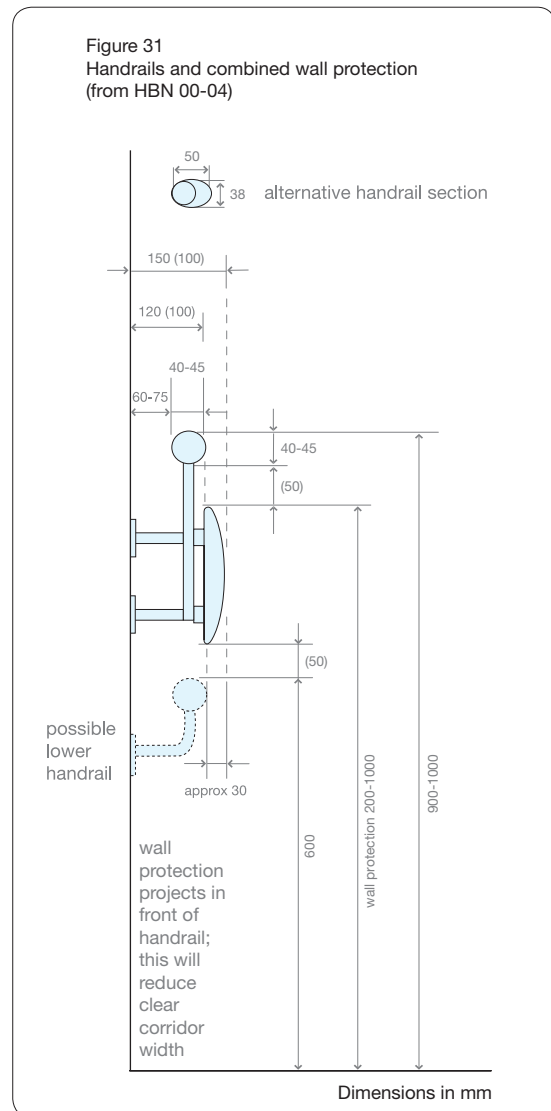
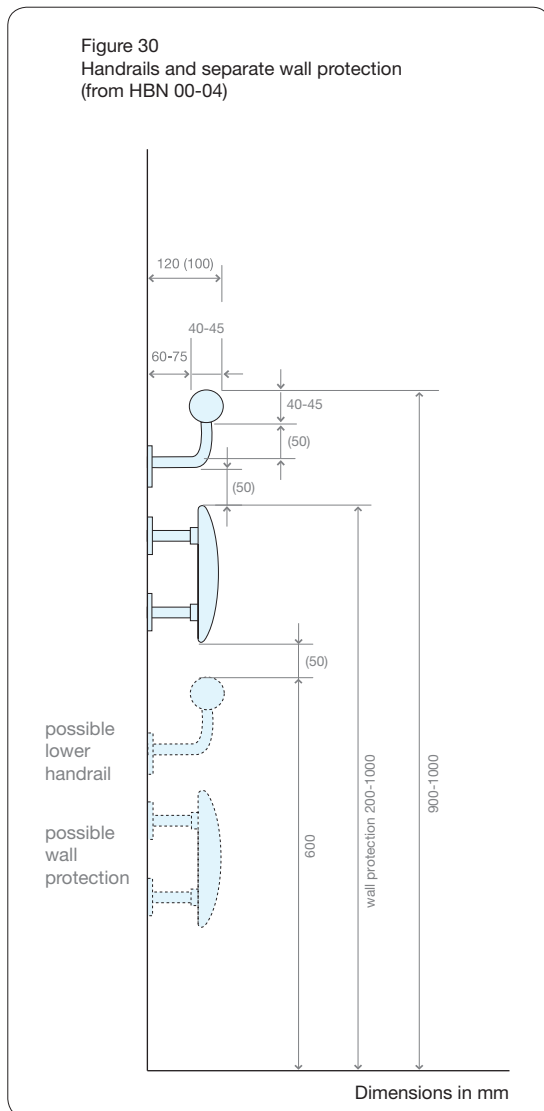

Source: Department of Health Estates & Facilities Division: Core Elements – Health Building Note 00-04: Circulation and communication spaces  
 Crown copyright material is reproduced with the permission of the Controller of HMSO and Queen's Printer for Scotland

# Specification Guidelines

## The Building Regulations, British Standards and Construction Guidelines for specifying the appropriate Gradus product

Extracts shown below show examples of best practice

### Mat (Material) 05 Designing for robustness

**No. of credits available: 1**

**Minimum standards: No**

#### Aim

To recognise and encourage adequate protection of exposed elements of the building and landscape, therefore minimising the frequency of replacement and maximising materials optimisation.

#### Assessment Criteria

The following is required to demonstrate compliance for:

#### One credit

1. Areas of the building have been identified (both internal and external) where vehicular, trolley and pedestrian movement occur.
2. The design incorporates suitable durability and protection measures or design features/solutions to prevent damage to the vulnerable parts of the building. This must include, but is not necessarily limited to:
  - a. Protection from the effects of high pedestrian traffic in main entrances, public areas and thoroughfares (corridors, lifts, stairs, doors etc).
  - b. Protection against any internal vehicular/trolley movement within 1m of the internal building fabric in storage, delivery, corridor and kitchen areas.
  - c. Protection against, or prevention from, any potential vehicular collision where vehicular parking and manoeuvring occurs within 1m of the external building façade for all car parking areas and within 2m for all delivery areas.

#### Compliance notes

Suitable durability measures

Suitable durability and protection measures to vulnerable parts of the building can include: 1.

Bollards/barriers/raised kerbs to delivery and vehicle drop-off areas 2.

Robust external wall construction, up to 2m high 3.

Corridor walls specified to Severe Duty (SD) as per BS 5234-21 and, for healthcare buildings, Health Technical Memorandum 56 – Partitions<sup>2</sup>

4. Protection rails to walls of corridors
5. Kick plates/impact protection (from trolleys etc) on doors
6. Hard-wearing and easily washable floor finishes in heavily used circulation areas (i.e. main entrance, corridors, public areas etc)
7. Designing out the risk without the need for additional materials specification to protect vulnerable areas.

#### Vehicle impact protection

Any vehicle impact protection measures specified must be positioned at an adequate distance from the building to protect the fabric from impact from any vehicle with a measurable overhang of the body from the wheel track, in particular for any goods delivery areas.

#### Compliance notes

Construction is specified to comply with the credit, additional protection must be provided to ensure against potential damage to the robust façade from vehicle movement, i.e. specifying bollards or protection rails.

#### Preventing excessive material use

The specification or design measures chosen should reflect the need to balance the additional specification of materials with the need to protect building elements to minimise their replacement, insuring against excessive material use and promoting materials optimisation.

---

### **Public / Common Areas**

Consideration should be given to materials specification in public/common areas (especially public waiting areas and toilet areas) to provide protection against potential malicious or physical abuse in as far as it is possible.

Sales areas (retail)

In any sales areas, where customer goods trolleys will be used, protection must be provided to vulnerable parts of the building (such as glass curtain walling etc.) within 1m of trolley movement.

## **Schedule of Evidence**

Req.

Design Stage

Post Construction Stage

All

Design drawings illustrating vulnerable areas/parts of the building.

Design drawings and/or relevant section/clauses of the building specification or contract confirming the durability measures specified.

BREEAM Assessor's site inspection report and photographic evidence AND/OR 'As built' drawings.

Gradus offers a comprehensive service for all aspects of wall protection ranging from advice on specification for supply only projects, through to a complete project management service for the supply and installation of Gradus Wall Protection Systems.

Gradus considers factors that would influence the specification in line with 'Mat 05 Designing for robustness' and facilitates this with extended service levels including on-site surveys, measuring and face-to-face advice from trained specification consultants.

Gradus can help with the assessment of a building in order to establish the types of wall protection required and appropriate locations/levels where it should be installed, ensuring products selected meet the requirements of the building.

Source: BREEAM New Construction Non Domestic Buildings Technical Manual - SD5073-2.0 : 2011

# Specification & Ordering Guidelines

## Handrails / Combi-rails / Dual Rail

- Brackets should be placed at centres to suit the substrate (maximum 800mm), however the number of brackets should be increased if the quality and type of substrate deem it necessary.
- Two additional brackets are required for every handrail / Dual Rail joint - they should be placed 100mm to either side of the join to ensure a secure finish.
- One extra bracket is required for every other return accessory used.
- One additional bracket is required for every inside/outside corner.
- InPro 950 Handrail, InPro 3500 / 3500W Dual Rail, 450 Timber Handrail and projected Bedhead protection systems - if fixed to a dry wall / stud partition, provision should be made for a plywood patress.
- Outside corner accessories are recommended to continue the handrail around a corner, with the option of using a corner guard for additional protection (see illustration below).
- In the event of encountering non-regular angles it may be necessary to finish at a corner using return accessories.
- Splices should always be used when joining multiple pieces to ensure secure, even and safe joins. (InPro only)
- Aluminium retainers and PVC-u covers are supplied in standard lengths to be cut on-site as required. (InPro only)
- InPro Handrails / Dual Rail / Timber Handrails are supplied with all fixings to secure accessories. Guidelines for substrate fixings (not supplied) can be obtained from the Gradus Technical Services department.

Note: InPro Handrails / InPro Combi-rails / InPro Dual Rail / Timber Handrails are designed for use in horizontal circulation areas and should not be specified for use on stairs, ramps or changes in level.

*Outside / inside corner accessories are recommended to continue the handrail around corners (with the option of using a corner guard for additional protection on outside corners).*

*For wall guards it is recommended to use end caps to finish either side of the corners (with a corner guard for extra protection on outside corners).*

## Wall Guards

- Wall guards can be used at specific points of impact to provide direct protection or can be used at alternative levels on the wall to provide indirect protection.
- The use of splices to join multiple lengths of wall guard is optional. However, they are recommended for use where joins occur in areas of specific heavy impact.
- It is recommended to use end caps to finish at every corner (rather than inside/outside corner accessories), with the option of using a corner guard for additional protection (see illustration below).
- Spacers are optional and can be used to add extra depth of protection and to take up minor undulations in the substrate. Note: Wall guards placed on spacers should not be specified as a handrail. The spacer option is not suitable for infinity systems.
- InPro wall guards are supplied with all fixings to secure accessories. Guidelines for substrate fixings (not supplied) can be obtained from the Gradus Technical Services Department.



NBSPlus

### TYPICAL NBS SPECIFICATION

Gradus is a member of NBS Plus to assist architects and other specifiers for guidance when writing specifications.

**BUILDING FABRIC SUNDRIES**  
P20: UNFRAMED ISOLATED TRIMS/SKIRTINGS SUNDRY ITEMS  
170

#### Handrail / Bumper Guard

Location: See drawings

Manufacturer:

Gradus Ltd, Park Green, Macclesfield, Cheshire SK11 7LZ

Tel: 01625 428922 Fax: 01625 433949

Web: [www.gradusworld.com](http://www.gradusworld.com)

Reference: InPro Wall Protection System

Type: 1200 Handrail, 158mm x 3660mm

Colour: See finishes schedule

Fixing: In accordance with manufacturers instructions

Accessories: 801 bracket, 1202/1203 returns, 1204/1205 outside / inside corners

NBS contact: Tel: 0845 456 9594 Email: [info@theNBS.com](mailto:info@theNBS.com)

NBSPlus

### TYPICAL NBS SPECIFICATION

Gradus is a member of NBS Plus to assist architects and other specifiers for guidance when writing specifications.

**BUILDING FABRIC SUNDRIES**  
P20: UNFRAMED ISOLATED TRIMS/SKIRTINGS SUNDRY ITEMS  
170

#### Wall Guard

Location: See drawings

Manufacturer:

Gradus Ltd, Park Green, Macclesfield, Cheshire SK11 7LZ

Tel: 01625 428922 Fax: 01625 433949

Web: [www.gradusworld.com](http://www.gradusworld.com)

Reference: InPro Wall Protection System

Type: 700 Wall Guard, 196mm x 3660mm

Colour: See finishes schedule







Fixing: In accordance with manufacturers instructions

Accessories: 701 end cap, 702/707 outside / inside corners, 1601 rubber spacer, 706 splice support

NBS contact: Tel: 0845 456 9594 Email: [info@theNBS.com](mailto:info@theNBS.com)

# Gradus InPro Product Characteristics

Gradus InPro products have undergone a series of rigorous tests to ensure they will perform to expectation throughout their life. Tests are undertaken in Gradus' purpose-built testing facilities, by independent testing houses and through observing and testing products in-situ. With over 45 years experience Gradus provides peace of mind to its customers.

<p><b>PVC-u:</b></p>	<p>Unplasticised polyvinyl chloride through coloured and textured to conceal the effects of impact and abrasion. Added impact modifiers enhance impact resistance.</p> <div style="display: flex; align-items: flex-start; gap: 10px;"> <div style="text-align: center;">  </div> <div> <p><b>Fire Performance:</b> Gradus Sanparrel PVC-u sheet has been tested in accordance with EN ISO 11925-2:2002 and EN 13823:2002 and classified according to EN 13501-1:2002 as - <b>Reaction to Fire classification: B - s3, d0</b></p> <p>Gradus InPro PVC-u material has been tested in accordance with EN ISO 11925-2:2002 and EN 13823:2002 and classified according to EN 13501-1:2002 as - <b>Reaction to Fire classification: B - s3, d0</b></p> </div> </div> <div style="display: flex; align-items: flex-start; gap: 10px; margin-top: 10px;"> <div style="text-align: center;">  </div> <div> <p><b>Chemical Resistance:</b> Tested in accordance with BS2782:Part 8. Method 830A:1986. ISO175-1981. Plastics - determination of the effects of liquid chemicals including water. The results show that the products as tested are resistant to most commonly used chemical solutions.</p> </div> </div> <div style="display: flex; align-items: flex-start; gap: 10px; margin-top: 10px;"> <div style="text-align: center;">  </div> <div> <p><b>Bacterial Resistance:</b> Tested in accordance with BS EN ISO 846-1997. Plastics - evaluation of the action of micro-organisms. The results show that the products as tested did not support bacterial growth.</p> </div> </div> <div style="display: flex; align-items: flex-start; gap: 10px; margin-top: 10px;"> <div style="text-align: center;">  </div> <div> <p><b>Fungal Resistance:</b> Tested in accordance with BS EN ISO 846-1997. Plastics - evaluation of the action of micro-organisms. The results show that the products as tested did not support fungal growth.</p> </div> </div> <div style="display: flex; align-items: flex-start; gap: 10px; margin-top: 10px;"> <div style="text-align: center;">  </div> <div> <p><b>Accelerated Wear Test:</b> A purpose built test rig simulates the most extreme impact a wall protection product is ever likely to encounter. A hospital bed is loaded with weights to represent a person and the bed is repetitively pushed towards a wall fitted with wall protection products, increasing the weights each time. This severe type of testing ensures that the specifier is supplied a robust product which withstands the most severe impact.</p> </div> </div> <div style="display: flex; align-items: flex-start; gap: 10px; margin-top: 10px;"> <div style="text-align: center;">  </div> <div> <p><b>VOC Testing – Sanparrel:</b> France has introduced new regulations relating to the labelling of building products used internally with regard to emissions of volatile polluting substances. Sanparrel has been tested for VSO emissions in accordance with ISO 16000. Emission test results after 28 days correspond to the emission Class A+ of the French regulation on the labelling of products for wall cladding on their emissions of volatile pollutants (April 2011).</p> </div> </div>
<p><b>Moulded Accessories:</b></p>	<p>Returns, inside corners, outside corners and brackets are hardwearing injection moulded thermoplastic, textured and colour matched to the PVC-u.</p>
<p><b>Aluminium:</b></p>	<p>Durable alloy 6060-T6 to BS1474.</p>
<p><b>Polycarbonate:</b></p>	<p>Impact resistant with International Fire Rating UL94HB.</p>
<p><b>Product Support:</b></p>	<p>Colour swatches, samples and further information are available on request from: Gradus Technical Support on 01625 428922 or visit: <a href="http://www.gradusworld.com">www.gradusworld.com</a></p>
<p><b>Installation:</b></p>	<p>Each order is supplied with comprehensive installation instructions. Installation details and advice are also available on request from: Gradus Technical Support on 01625 428922 or visit: <a href="http://www.gradusworld.com">www.gradusworld.com</a></p>
<p><b>Maintenance:</b></p>	<p>Maintenance details available on request from: Gradus Technical Support on 01625 428922 or visit: <a href="http://www.gradusworld.com">www.gradusworld.com</a></p>

# Product Index

Product	Page	Product	Page	Product	Page	Product	Page
11209	42	169	39	293	64	903	21
11209N	42	169BN	40	293CMT	64	904	21
11212	42	169F	41	293HOLE	64	904/135	21
11212N	42	170 Series	39	296135	42	906	21, 27
11235	42	1700	55	296135N	42	909	21
11235N	42	170BN Series	40	309135	42	950	19, 20
11248	42	170F Series	41	309135N	42	951	21
11248N	42	1712	39	312135	42	952	21
11296	42	1712BN	40	312135N	42	953	21
11296N	42	1712F	41	3309	42	954	21
1200	19, 20	171TC	39, 40	3309N	42	959	21
1202	21	173	39	3312	42		
1203	21	1736	55	3312N	42	Admiral 165	17
1204	21	173BN	40	3335	42	Amethyst 171	17
1204/135	21	174	39	3335N	42	Approved Document M	70-71
1205	21	1748	55	3348	42	Arctic 101	16
1205/135	21	174BN	40	3348N	42	ARM150	34
121TC	39, 40	178	39	335135	42	ARM150N	34
130 Series	39	178BN	40	335135N	42	ARM150T	34
1300	29, 32, 36	178F	41	3396	42	ARM200	34
1302	33, 36	179	39	3396N	42	ARM200N	34
1303	33	1796	55	3409	42	ARM200T	34
1307	33	179BN	40	3409N	42	Armaclad	34
130BN Series	40	179F	41	3412	42	Ash 401	23
130CMT	64	180	63	3412N	42	Bed Locators	35, 37
130F Series	41	1800	29, 30	3435	42	Bed Head Protectors	35, 36
130HOLE	64	1800i	29, 30	3435N	42	Beeswax 249	16
1312	39	1801L	31	3448	42	Birch 151	16
1312BN	40	1801R	31	3448N	42	BL1300	36
1312F	41	1802	31	348135	42	BL6000	37
133	39	1803	31	348135N	42	BL800	36
133BN	40	1804CMT	63	3496	42	Black 152	16
134	39	1804HOLE	63	3496N	42	BLXB2	37
134BN	40	1808CMT	63	3500	25, 26	Bollards	62
138	39	1808HOLE	63	3500W	25, 26	BS8300:2009 + A1:2010	72-73
138BN	40	181	63	3501	27	Bumper Rails	see Wall Guards
138F	41	181CMT	63	3501W	27	CGR119	67
139	39	181HOLE	63	3502	27	Chamomile 232	16
139BN	40	185	63	3503	27	Cherry 236	17
139F	41	1854CMT	63	3504	27	Cinnamon 235	17
1400	32	1854HOLE	63	3505	27	Colour Availability	16-17
1400i	32	1858CMT	63	396135	42	Combi-rails	18-21
1402	33	1858HOLE	63	396135N	42		
1403	33	190	64	406	47	<b>Corner Guards</b>	
1407	33	190CMT	64	407	47	Clear Polycarbonate	43
150 Series	39, 55	190HOLE	64	408	47	Flexi-Angle	43
1500	30	193	64	409	47	Flush Mount	41
1500i	30	193CMT	64	4118	43	High Impact	39-41
1501L	31	193HOLE	64	4212135	43	Rubber	67
1501R	31	200	32	421290	43	Stainless Steel	63
1502	31	2000	20	434	43	Standard PVC-u	42
1503	31	2001	21	450	23	Surface Mount	39-40, 42-43, 55
150BN Series	40	2002	21	456	23, 27		
150F Series	41	2003	21	500	32	Corner Rails	63
1512	39	2004	21	501	33, 36	Crash Rails	see Wall Guards
1512BN	40	2004/135	21	502	33	D-Fender	67
1512F	41	201	33	503	33	Daybreak 115	17
151TC	39, 40	202	33	507	33	DEG/A40	56
153	39	207	33	581	47	DEG/A44	56
153BN	40	209135	42	6009	43	DEG/A46	56
154	39	209135N	42	6009N	43	DEG/A55	56
154BN	40	212135	42	6012	43	DEG/A65	56
158	39	212135N	42	6012N	43	DEG/B44	56
158BN	40	2209	42	6035	43	DEG/B46	56
158F	41	2209N	42	6035N	43	DEG/B55	56
159	39	2212	42	6048	43	Dolphin 106	16
159BN	40	2212N	42	6048N	43	Door Protection	52-55, 64
159F	41	2235	42	6096	43	Dual Rail	24-27
160 Series	39, 55	2235N	42	6096N	43	E-Fender	67
1600	30	2248	42	700	30	Eggshell 111	16
1600i	30	2248N	42	700i	30	Extender Brackets	37
1601	31	2296	42	701	31	FBC Collar	23, 27
1606	31	2296N	42	702	31	Flax 113	16
1606i	31	235135	42	706	31	Flexi-Angle	43
160BN Series	40	235135N	42	706i	31	Floor Rails	62
160F Series	41	248135	42	707	31	FRI/01/AA/2.1	55
1612	39	248135N	42	800	20, 36	FRI/02/AA/2.1	55
1612BN	40	2509	42	801	21, 36	FRI/03/AA/2.1	55
1612F	41	2509N	42	802	21, 36	FRI/EC	55
161TC	39, 40	2512	42	803	21		
1622	31	2512N	42	803/135	21	<b>Handrails</b>	
1623	31	2535	42	804	21, 27	PVC-u	18-21, 24-27
1627	31	2535N	42	805	21	Stainless Steel	60-61
163	39	2548	42	805/135	21	Timber	22-27
163BN	40	2548N	42	8118	43		
164	39	2596	42	8212135	43	HBN 00-04	74-75
164BN	40	2596N	42	821290	43	HBN 00-10	73
168	39	290	64	834	43	Hessian 118	16
168BN	40	290CMT	64	900	20	HTM 69	73
168F	41	290HOLE	64	902	21	Kickplates	52, 64
						Lagoon 286	17
						Lemon 216	16
						Lupin 132	17
						Maple 403	23
						Mat 05	76-77
						Mint 248	17
						Muslin 103	16
						Oak 402	23
						Ordering Guidelines	78
						Papaya 271	16
						Peach 273	17
						Petrol 134	17
						Pewter 107	17
						Product Characteristics (InPro)	79
						Rapid Response	16
						Rose 149	16
						Rubber - Heavy Duty	66-67
						Rubrails	48
						Russet 257	17
						Sanparrel Bespoke Solutions	49
						Sanparrel Rubrails	48
						Sanparrel Sheet	47
						Seaspray 262	17
						Sherwood 125	17
						Specification Guidelines	70-77
						SS3502W	27
						SS3503W	27
						SS3504W	27
						SS3505W	27
						SS454	23
						SSCR51C	63
						SSCR51S	63
						SSFR51	62
						SSFR51A135	62
						SSFR51A90	62
						SSFR51EC	62
						SSFR51RET/180	62
						SSFR51RET/230	62
						SSFR51HD/230	62
						SSFR51FB/180	62
						SSFR51SFB/180	62
						SSFR51P/180/D	62
						SSFR51P/180/S	62
						SSFR51P/230/D	62
						SSFR51P/230/S	62
						SSFR51SP	62
						SSHR45	61
						SSHR45/A90	61
						SSHR45/EC	61
						SSHR45/RET	61
						SSHR45/SBTKT	61
						SSHR45/SPLICE	61
						SSP51/1000	62
						SSP51/550	62
						SSP76/1000	62
						SSP76/550	62
						SSWGA1	59
						SSWGA2	59
						SSWGA3	59
						SSWGA4	59
						SSWGB1	59
						SSWGB2	59
						SSWGC1	59
						SSWGC2	59
						Stainless Steel	58-64
						T3502W	27
						T3503W	27
						T3504W	27
						T3505W	27
						T454	23
						T951	23
						T959	23
						Tempest 134	17
						Testing	79
						Timber Handrail	22-23
						Utile 404	23
						<b>Wall Guards</b>	
						PVC-u	28-33
						Rubber	67
						Stainless Steel	59
						Wall Strips	34
						WGR107D	67
						WGR150E	67
						WGR200E	67
						Wheat 109	16
						Willow 187	17

# Trademarks

---



Gradus website:  
[www.gradusworld.com](http://www.gradusworld.com)

All trademarks, product names and codes detailed within this catalogue are the property of Gradus Ltd.

- Armaclad®
- Dual Rail™
- Gradus®
- InPro®
- Sanparrel™



**www.gradusworld.com**  
**call: 01625 428922**

# GRADUS

**Gradus Accessories Park Green Macclesfield Cheshire SK11 7LZ England UK Tel: 01625 428922 Fax: 01625 433949**  
For enquiries outside the UK and Eire contact Gradus International on +44 (0)1625 613780

Gradus International  
England  
Tel +44 (0) 1625 613780

Gradus Far East  
Singapore  
Tel: (+65) 6734 5933

Gradus Middle East  
United Arab Emirates  
Tel: (+971) 4887 6540

Gradus France  
France  
Tél: (+33) 1 8114 9300

This catalogue supersedes and replaces all previous issues.  
All designs and illustrations contained within this catalogue remain the copyright of Gradus Ltd.©  
All trademarks, product names and codes detailed within this catalogue are the property of Gradus Ltd.