



TYPE 6224

**Integrating Precision
Sound Level Meter**

Instruction Manual

(Version 1.6C)

Thank you for buying a Castle product, I am sure you will find both the goods and the service to be of the highest quality but if not, then please feel free to write to me personally and I will ensure that your needs are dealt with immediately.

This manual is designed to show you the operation of the goods you have purchased and a very brief insight into acoustics itself. If you would like to become a competent person in the eyes of the law, then you may like to know more about our Competent Persons training course for the Noise at Work Regulations.

It is my intention for Castle Group Ltd to provide a complete range of Noise and Vibration products and Services of the highest standard. If you would like to know more about any of our other products and services then please telephone on +44(0)1723 584250.

A handwritten signature in black ink, consisting of several overlapping loops and a horizontal line extending to the right.

Simon Bull
Managing Director

Copyright

This manual is copyrighted with all rights reserved. The manual may not be copied in part or in whole without the prior written consent of Castle Group Ltd.

Precautions

- Only operate the instrument as described in this manual.
- These are precision instruments, protect from shocks and vibrations.
- Take special care with the microphone. The diaphragm is made from a very thin metal and is easily damaged.
- Ambient conditions for the operation of the unit are as follows:-
 - Temperature -10°C to +50°C
 - Relative Humidity 25 to 90%
- Protect the unit from extremes of temperature and humidity, direct sunlight and air with a high salt or sulphur content.
- Always turn the unit off after use. Remove the batteries from the instrument when not in use.
- Do not use any solvents or cleaning agents on the instrument. Use only a soft dry cloth or a soft cloth lightly moistened with water when necessary.
- Do not let any conductive objects, such as wire or metal scraps get into the unit.
- Do not try to disassemble the instrument or attempt any repairs as this will invalidate your warranty. Take a note of the condition of the instrument and contact your authorised Castle service station.
- To ensure continued precision performance of your instrument have it checked and serviced at regular intervals.

Contacting Castle Group

This manual contains complete operating instructions for the Castle 6224 Integrating Precision Sound Level Meter, read it carefully and you will quickly become familiar with your instrument and its operation.

If you do encounter problems with the operation of your instrument please feel free to contact customer support with your enquiry on: -

techsupport@castlegroup.co.uk

For all other enquires please contact us on either: -

+44 (0)1723 584250	Telephone
+44 (0)1723 583728	Fax
www.castlegroup.co.uk	Web Site

Introduction

1. Overview

The Castle 6224 (Class 1) Integrating Sound Level Meter is ideally equipped for carrying out Noise at Work Risk Assessments, as well as the majority of environmental survey work. The range of parameters measured, the wide measuring capability of the meter and the ease of use, mean that this equipment is suitable for anything from aircraft noise to lawnmower design, and from construction sites to laboratories.

The Castle 6224 has an easy to follow menu system and clearly marked keys, all designed to make the meter simple-to-use. The back-lit LCD display is also very clear with large figures and a quasi-analogue display bar to show the changes in sound level as they happen.

2. Features

- Equivalent continuous level (Leq)
- 5 user selectable percentile values (Ln)
- Wide Linearity range of 90dB
- RS232 for data output to optional software
- Memory storage for 10,000 data-points

3. Configuration

(1) Integrating Sound Level Meter	TYPE 6224	1
(2) 1/2"electret condenser microphone	TYPE 7146N	1
(3) Windshield (∅50)		1
(4) Screwdriver		1
(5) Wrist strap		1
(6) Carrying case		1
(7) Instruction manual		1
(8) Optional extras		
• AC adaptor		PSU4
• Extension cable(2m, 5M. 10m)		ZL0046-02, 05, 10
• Interface cable		ZL0026
• Output cable(BNC pin cord)(2m)		ZL0071
• Data management software (with Interface Cable)		PC0226-4

Contents

Section 1 Setting up

1. Locations and their functions	5
2. Battery installation	6
3. AC power adaptor	6
4. LCD adjustment	7
5. Calendar adjustment	8
6. LCD backlight	9

Section 2 Basic Operation

1. Changing Display mode	10
2. Operation of panel switches and their function	13
3. Calibration	14

Section 3 Measuring Procedure

1. A-weighted sound pressure level (L _A) measurement.....	16
2. Sound pressure level (L _c /L _f) measurement	17
3. Equivalent continuous A-weighted sound pressure level (L _{Aeq}) measurement	18
4. Single event sound exposure level (L _{Ae}) and Percentile level (L _x) measurement.....	19
5. Max Hold Measurement	20
6. C-weighted waveform peak hold measurement (L _{CPeak})	21

Section 4 Menu

1. How to use Menu	22
2. Menu (1/2).....	23
3. Mode Set (2/2).....	24

Section 5 AC, DC Output

1. AC Output	25
2. DC Output	25

Section 6 Printing..... 26

Section 7 Data Transfer to a Personal Computer..... 28

Section 8 Specifications..... 29

Pin Connections and How to Connect the Extension cable..... 30

Section 1 Setting up

1. Locations and their functions

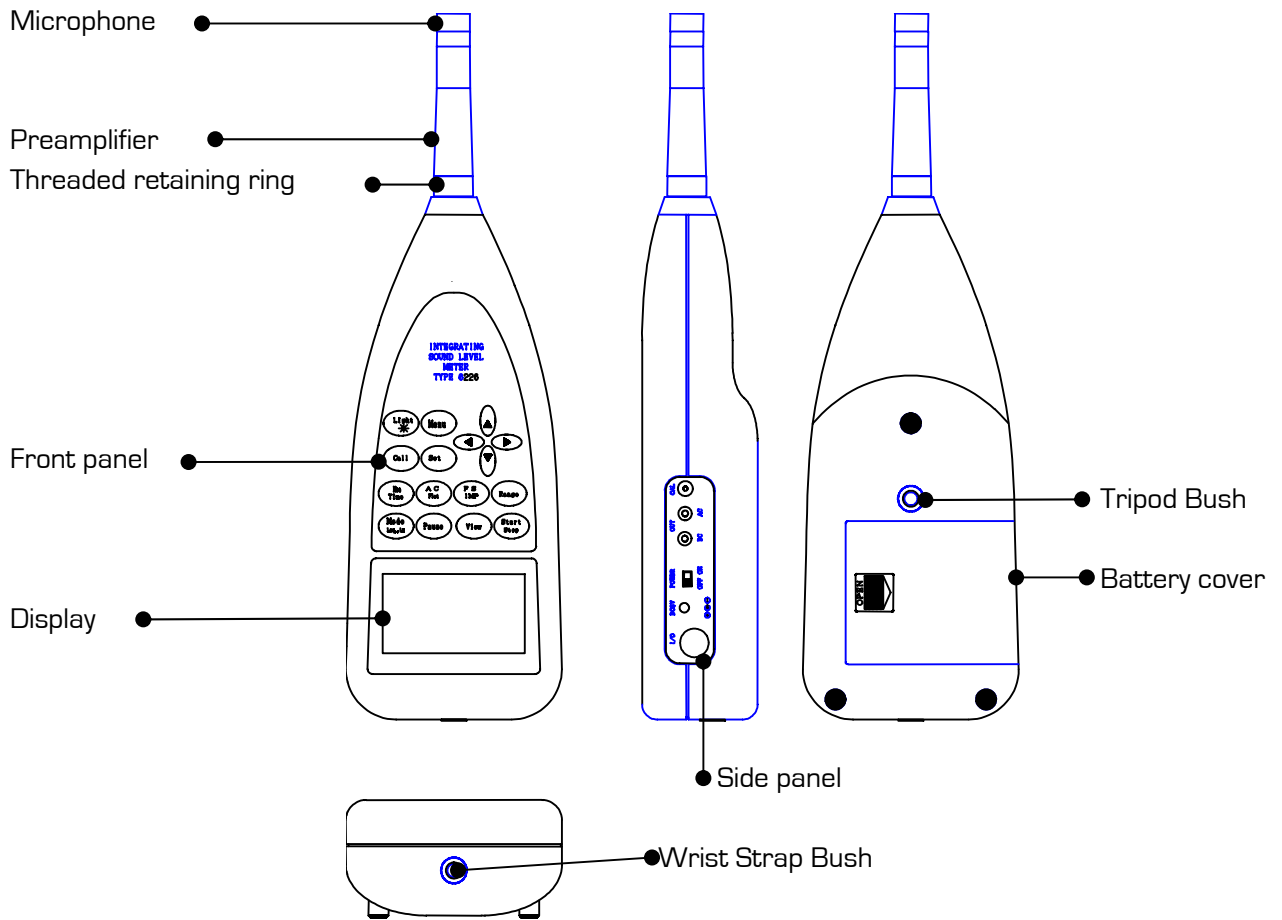

Side panel

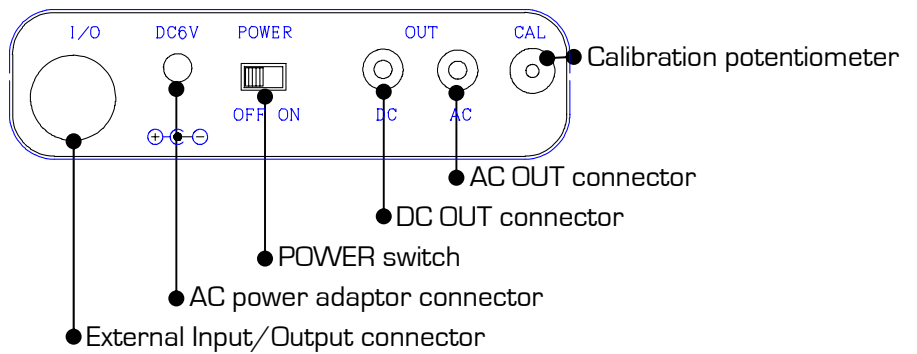

2. Battery installation

When the display indicates low battery, install new batteries.

For long-term measurement, install new batteries in advance.

The following diagrams indicate the battery condition.



To install new batteries:

- 1) Turn off the POWER switch.
- 2) Push the Battery cover gently where it says 'OPEN' and slide it to the right.
- 3) Insert the new batteries according to the diagram inside the battery compartment and replace the cover.

CAUTION

Place each individual battery with the positive terminal to the positive markings on the case. All four batteries should be replaced at the same time.

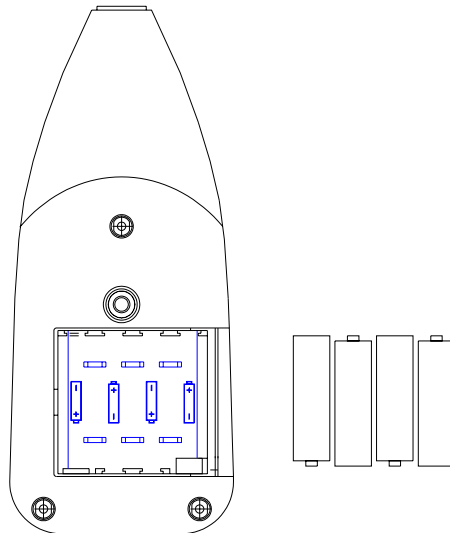

- Battery life is approximately:
 - 20 hours (Alkaline batteries, continuous operation)
 - 10 hours (Manganese batteries, continuous operation)
- Use of the LCD backlight shortens the life of the batteries (approximately 1/3).

3. AC power adaptor

- 1) Turn off the POWER switch.
- 2) Connect the optional AC power adaptor to the AC power adaptor connector.
- 3) Place the AC plug in the AC 240V outlet.

CAUTION

The use of an AC power adaptor other than the one recommended may cause damage to the instrument.

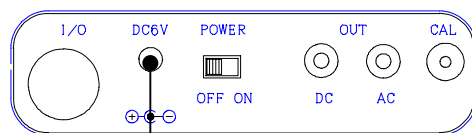

● AC power adaptor connector

4. LCD adjustment

The LCD contrast can be adjusted when the batteries are low or when new batteries are installed. The procedure is as follows.

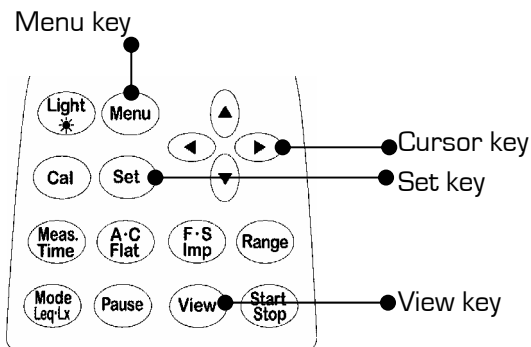

1) When you press the **Menu** key, the following screen appears.

<menu>	1/2
Meas Mode	: Manu
Interval	: Single
I/O	: OFF
Data delet	: OFF
LCD cont	: * * * * *
date y/m/d	: 00/01/01
time	: 00:00:00

- 2) Select **LCD cont** with **Cursor** key ▼, then move the cursor to the right with ► key.
- 3) Adjust the LCD contrast with ▲ ▼ key, then press **Set** key to save the setting. Asterisks indicate the degree of contrast. After pressing **Set** key, the cursor moves to the left.
- 4) To go back to measurement mode, press the **View** key.

5. Calendar adjustment

To adjust the calendar (time), operate as follows.

The calendar can be adjusted in the Menu mode in the same way as the LCD adjustment.

1) When you press the **Menu** key, the following screen appears.

The keypad layout is as follows:

- Row 1: Light *, Menu, (Up arrow)
- Row 2: Cal, Set, (Left arrow), (Right arrow)
- Row 3: Meas. Time, A-C Flat, F-S Imp, Range
- Row 4: Mode Leq Lx, Pause, View, Start Stop

The menu screen displays the following information:

```

<menu> 1/2
Meas Mode : Manu
Interval   : Single
I/O       : OFF
Data delet : OFF
LCD cont  : *****
date y/m/d : 00/01/01
time      : 00:00:00
  
```

Labels in the diagram point to the **Menu** key, **Cursor key** (up, down, left, right arrows), **Set key**, **View key**, and the **date y/m/d** and **time** fields in the menu screen.

【Calendar adjustment】

- 1) Select **date y/m/d** with **Cursor** key ▼, then move the cursor to the right with ► key.
- 2) Set the year/month/day with ▲▼ key, then press **Set** key to save the setting.
After pressing **Set**, the cursor moves to the left.
- 3) To return to the measurement mode, press **View** key.

【Time adjustment】

- 1) Select **time** with **Cursor** key ▼, then move the cursor to the right with ► key.
- 2) Set the hour:minute:second with ▲▼ key, then press **Set** key to save the setting.
After pressing **Set**, the cursor moves to the left.
- 3) To return to the measurement mode, press **View** key.

【Caution】

Be sure to enter the date (date y/m/d) in the order of "year → month → day."

Input any figure of; y(year): 00 - 99, m(month): 01 - 12, and d(day): 01 - 31.

e.g.: - For November 30, 2003 input 03/11/30

Be sure to enter the time in the order of "hour → minute → second."

Input any figure of; h(hour): 00 - 24, m(minute): 00 - 59, s(secOond) 00 - 59.

e.g.: - For 23:58:32 input 23/58/32

<Entry of incorrect date and time>

The instrument has a function for outputting measured data to a personal computer.

During transfer of data, if an incorrect date and time are entered, an error message "**Econver Error**" is displayed on the screen and data transfer cannot be carried out.

6 . LCD backlight

Your Castle 6224 is equipped with a backlight on the display.

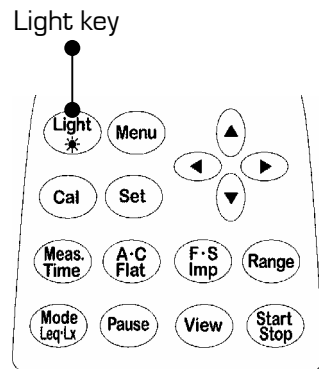

- 1) Press the **Light** key and the LCD backlight illuminates.
- 2) Pressing the **Light** key again turns the backlight off.
The backlight automatically turns off after approximately 30 seconds.
- 3) When the batteries are low the LCD backlight will dim.

CAUTION

Use of the LCD backlight shortens the life of the batteries.

Section 2 Basic Operation

1. Changing The Display mode

1 – 1 How to change the display mode

The display has three modes (Normal, Magnified and List Mode).

They can be changed with the **View** key.

The **View** key can be used to go back to this display mode from any other menu screen.

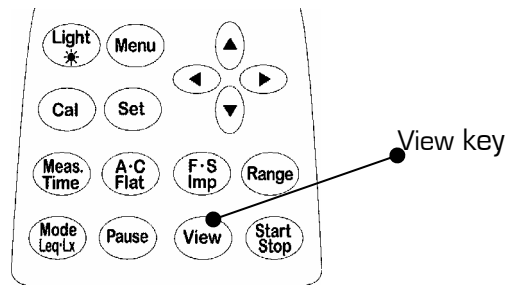

Normal Display Mode

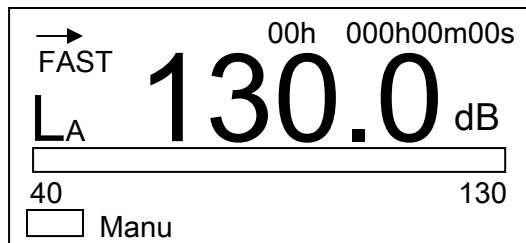

Magnified Display Mode

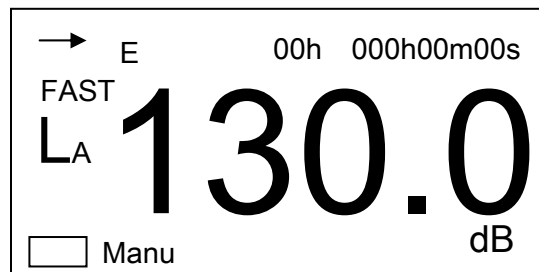

List Display Mode

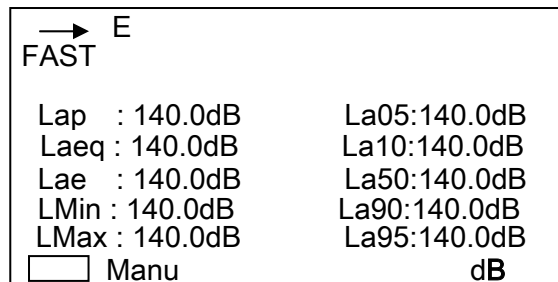

1 – 2 Normal Display Mode

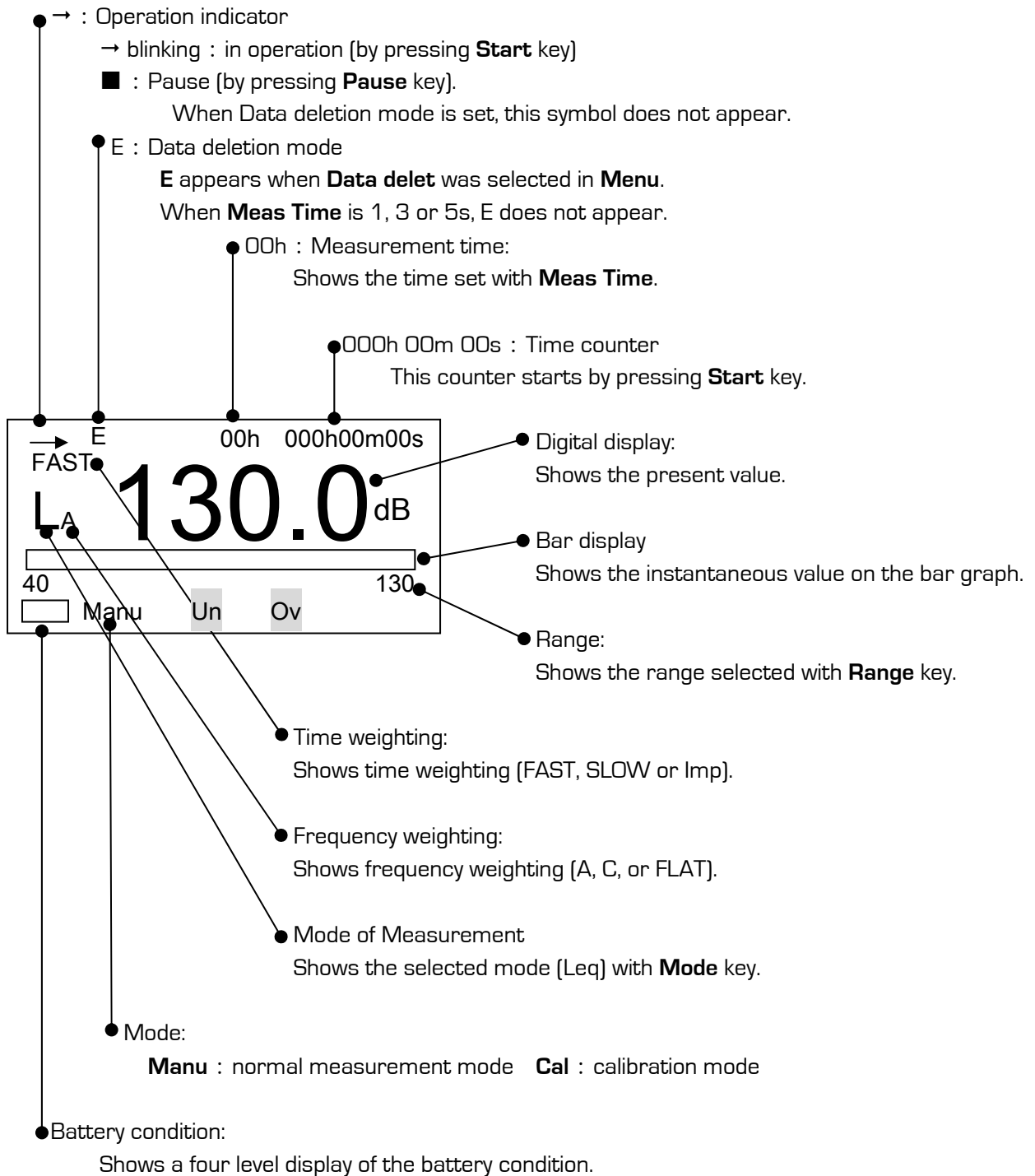

- When the input signal level is lower [-0.6dB] than the limited scale of the selected range, **Un** appears.
- When the input signal level is higher [+3dB] than the limited scale of the selected range, **Ov** appears.
- The digital display shows the time-weighted or frequency-weighted value.
- The digital display is updated once per second.
- The bar display is updated 10 times per second.

1 – 3 Magnified Display Mode

In magnified display mode, the bar graph does not appear and the numerical characters are magnified in the digital display.

In the magnified display mode it is possible to change between A-weighted sound pressure level, sound pressure level, equivalent continuous A-weighted sound pressure level, or percentile level measurement using the **Mode** key.

The other functions in this mode are the same as in the normal display mode.



Note: The value of percentile level shown on the Normal or Magnified display is selected on the <Mode Set> page 2/2 of <menu> pages.

1 – 4 List Display Mode

All the measured data is shown in the list mode.

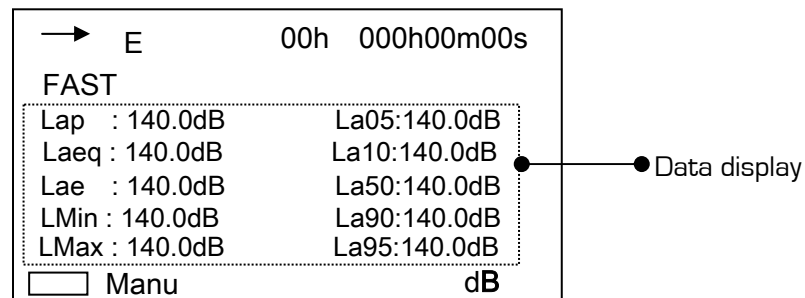

2. Operation of panel switches and their function

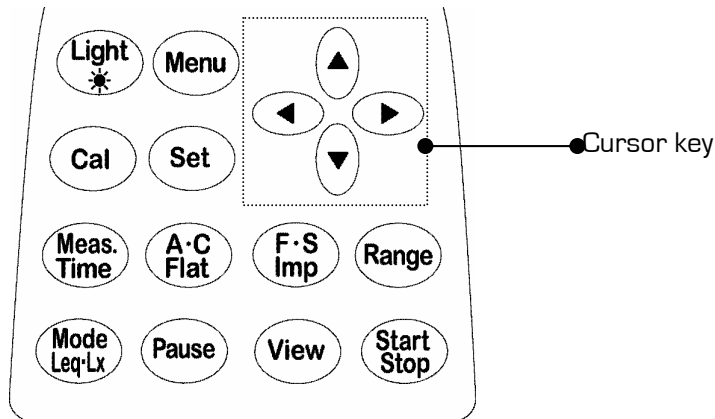

- **Light** : LCD backlight key
See "LCD adjustment".
- **Menu** : Menu key
See "Menu".
- **Set** : Set key
Saves the settings of the menu screen or resets Max Hold value.
- **Cursor key** : is used to move a cursor to select an item.
- **Cal** : Calibration key
See "Calibration".
- **Meas. Time** : Measurement time selection key
See "Measurement Procedure".
- **A·C·Flat** : Frequency Weighting Key
See "Measurement Procedure".
- **F·S·Imp** : Time Weighting Key
See "Measurement Procedure".
- **Range** : Range selection key
See "Measurement Procedure".
- **Mode** : Mode selection key
See "Measurement Procedure".
- **Pause** : Pause key
See "Measurement Procedure".
- **View** : Display mode key
See "Changing Display mode".
- **Start Stop** : Start and Stop key
See "Measurement Procedure".

3. Calibration

It is recommended that the instrument's calibration is checked and adjusted where necessary with a Castle GA607, Class 1 calibrator before readings are taken. The calibration should be re-checked after taking readings to confirm the validity of the results.

There are two types of calibration:

- 1) Using the recommended Castle GA607, which supplies typically 94dB/104dB (relative to 20μPa pressure) at a frequency of 1kHz.
- 2) Using the internal calibration mode. The internal calibration should only be used as a general system check e.g. for a broken or damaged microphone or for electrical calibration by a calibration house, it should not be used for field calibration. To maintain Class 1 accuracy the Castle GA607 must be used.

3 – 1 Calibration using the Castle GA607

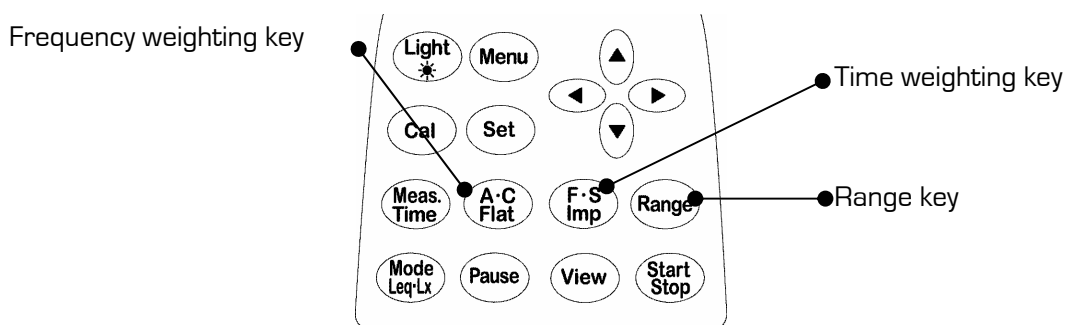

- 1) Turn on the POWER switch.
- 2) Set the frequency weighting to **A** with **Frequency weighting key**.
- 3) Set the time weighting to **Fast** with **Time weighting key**.
- 4) Set the range to **30~120dB** with **Range key**.
- 5) Ensure the calibrator is attached to the microphone by gently inserting the microphone into the cavity of the calibrator. A certain amount of resistance should be felt whilst inserting the microphone as the o-ring seal on the calibrator forms a seal around the microphone. Ensure that the calibrator is switched on and set to the chosen level and all correction factors for atmospheric pressure and microphone type have been accounted for, please refer to your Castle Calibrator Manual for more detail.
- 6) Adjust the calibration potentiometer on the side panel until the display shows the output level of the GA607 [standard value is 94.0dB].

Please note that the calibrator automatically turns OFF after approximately one minute.

< Calibration display >

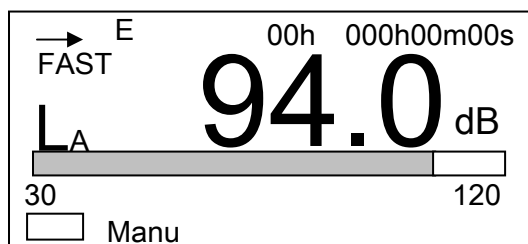

3 – 2 Calibration using internal calibration mode

The instrument can be calibrated using the internal generator (1kHz, sine wave)

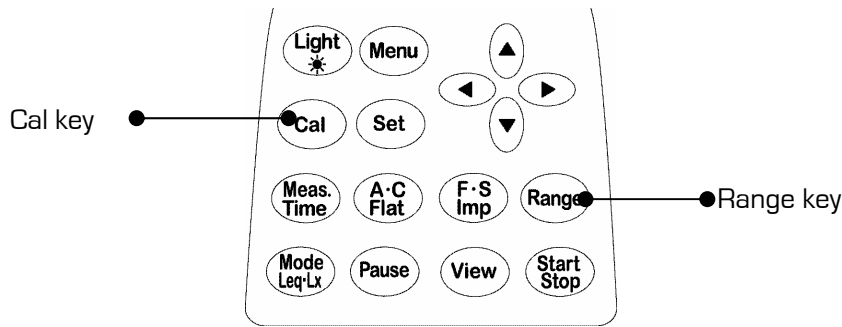

- 1) Turn on the POWER switch.
- 2) Press the **Cal** key.
- 3) Press the **Range** key, and choose '100dB' using the cursor keys ▲▼ and press the **Range** key again to confirm.
- 4) Adjust the calibration potentiometer on the side panel until the display shows 94dB.
- 5) Press the **Cal** key once again to complete the calibration.

< Calibration display >

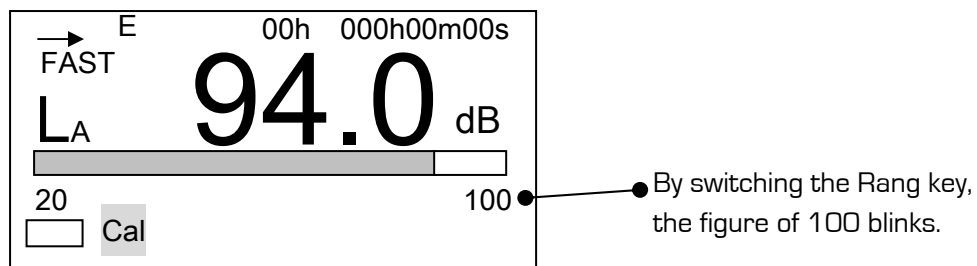

< Side panel >

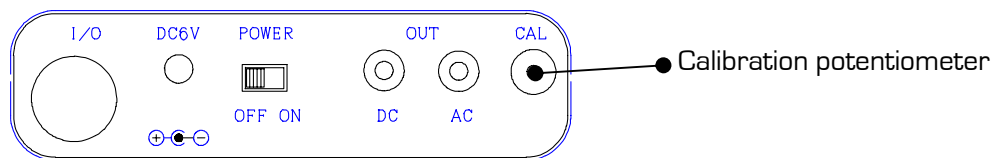

< Reference > Full scale range and Cal [the display shows]

Full scale Range [dB]	CAL [dB]	OUTPUT VOLTAGE (V)	
		AC OUT	DC OUT
80	74.0	0.500	2,350
90	84.0	0.500	2,350
100	94.0	0.500	2,350
110	104.0	0.500	2,350
120	114.0	0.500	2,350
130	124.0	0.500	2,350

< Reference > Relation between the display value of each range, and output voltage

DISPLAY VALUE (dB)						OUTPUT VOLTAGE (V)	
RANGE						AC OUT	DC OUT
40~130	30~120	20~110	20~100	20~90	20~80		
130	120	110	100	90	80	1.00000	2.50000
120	110	100	90	80	70	0.31623	2.25000
110	100	90	80	70	60	0.10000	2.00000
100	90	80	70	60	50	0.03162	1.75000
90	80	70	60	50	40	0.01000	1.50000
80	70	60	50	40	30	0.00316	1.25000
70	60	50	40	30	20	0.00100	1.00000
60	50	40	30	20	—	0.00032	0.75000
50	40	30	20	—	—	0.00010	0.50000
40	30	20	—	—	—	0.00003	0.25000

Section 3 Measuring Procedure

1. A-weighted sound pressure level (LA) measurement

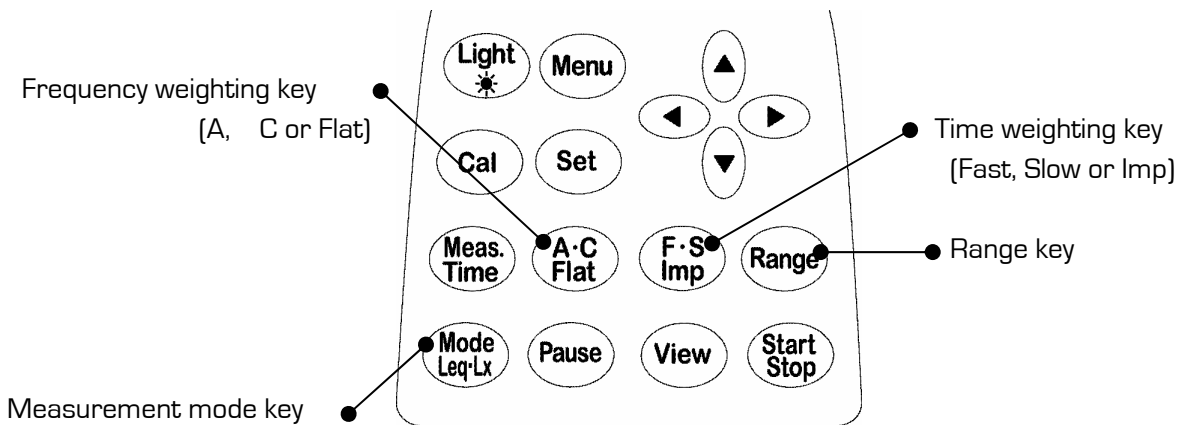

< Parameter setting >

- Range key** : Select a range where the Bar display indicates approximately 2/3 of the full scale.
- Time weighting key** : Fast or Slow
- Frequency weighting key** : A
- Measurement mode key** : LA

< Display >

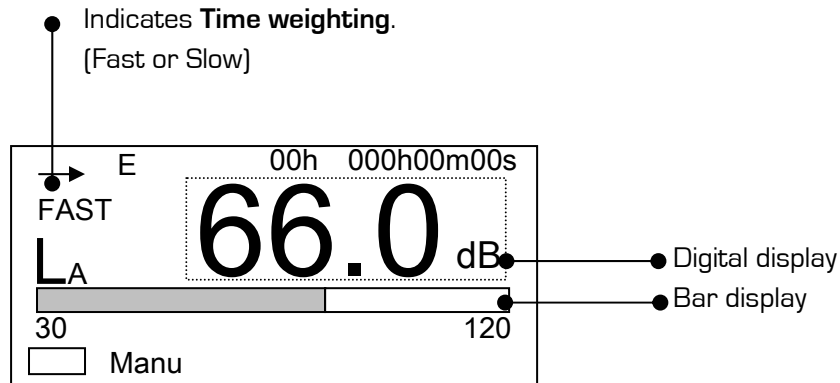

- The displayed LA level is updated once per second.
- The bar display is updated 10 times per second.
- There is no need to press the **Start** key.

2. Sound pressure level (Lc/Lf) measurement

(Sound pressure level measurements except A-weighted sound pressure level.)

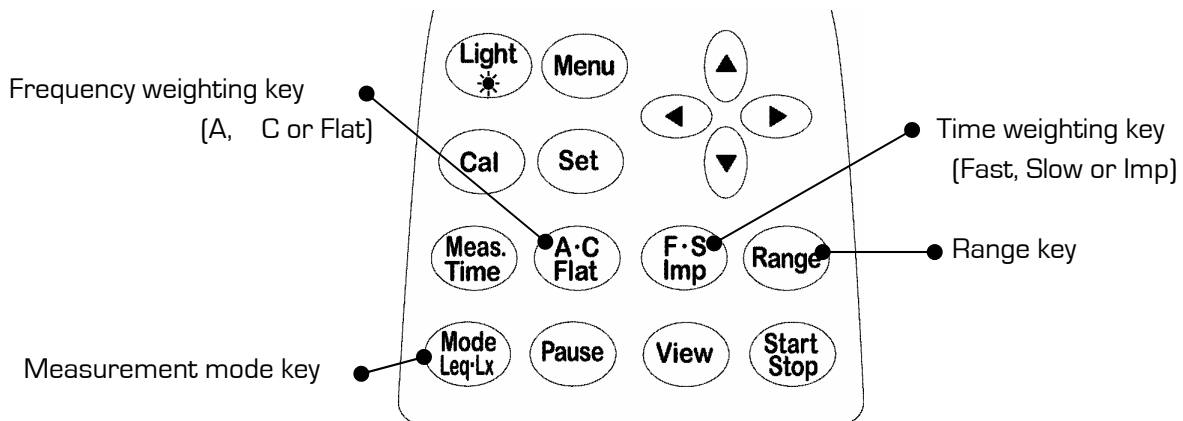

< Parameter setting >

- Range key** : Select a range where the Bar display indicates approximately 2/3 of the full scale.
- Time weighting key** : Fast or Slow
- Frequency weighting key** : C or F
- Measurement mode key** : Lc or Lf

< Display >

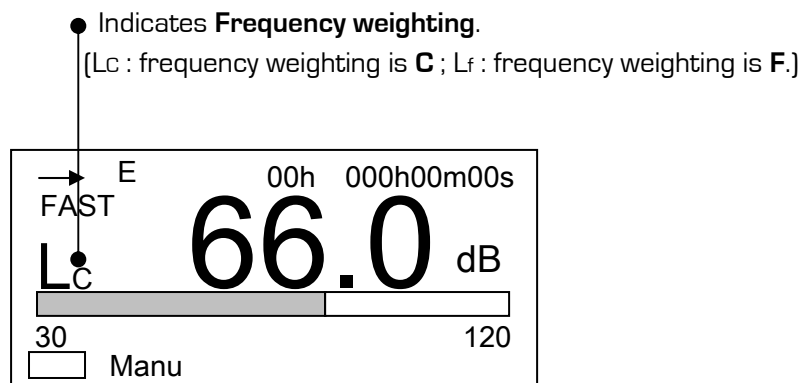

- The displayed level is updated once per second.
- The bar display is updated 10 times per second.
- There is no need to press the **Start** key.

3. Equivalent continuous A-weighted sound pressure level (L_{Aeq}) measurement

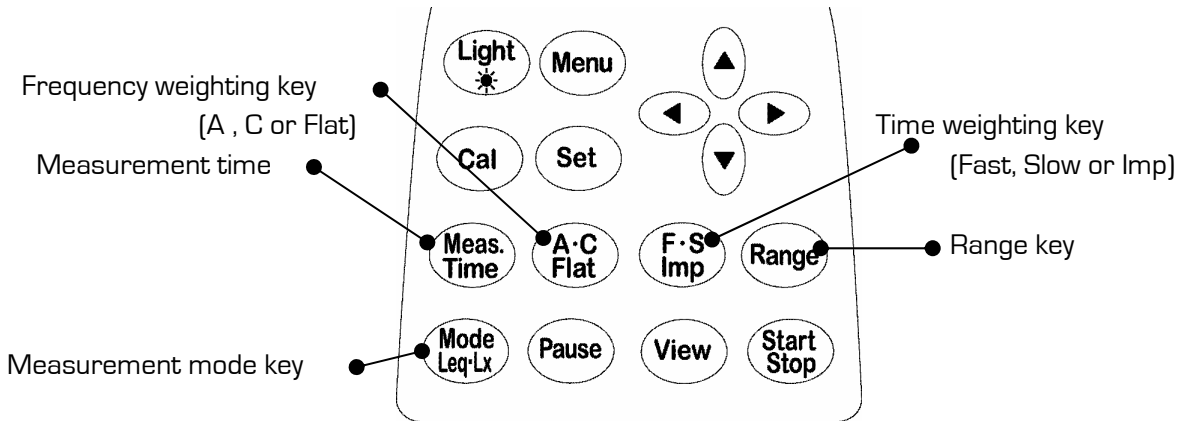

< Parameter setting >

- Range key** : Select a range where the Bar display indicates approximately 2/3 of the full scale.
- Time weighting key** : Fast or Slow
- Frequency weighting key** : A
- Measurement time key** : 1s, 3s, 5s, 10s, 1m, 5m, 10m, 15m, 30m, 1h, 8h, 24 h and * * * .
[* * * : the measurement continues until the **Stop** key is pressed.]
- Measurement mode key** : LAeq

< Display >

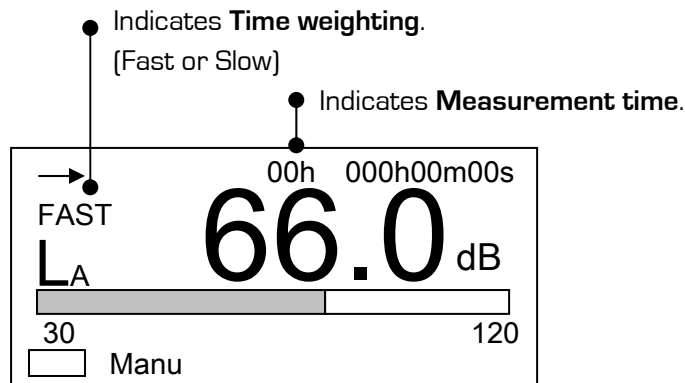

- Measurement starts by pressing the **Start** key, and automatically stops at the **Measurement time**. The digital display indicates the calculated data at that time.
If the **Stop** key is pressed during measurement, the digital display indicates the calculated data at that time. When the **Interval** is set to **repeat** in the **Menu** display, the measurement is repeated in every **Meas Time**. [This function is useful for printouts and data transfer to a computer.]
- If the **Pause** key is pressed during measurement, then the display indicates the calculated data from the start point to the current time less 3 or 5 seconds, whichever is selected for 'Data delet' in the **Menu**. To set this function, See **Menu**.
- When * * * is selected, the display indicates the calculated data at the time the **Stop** key is pressed. If the **Stop** key is not pressed, the measurement continues for 199 hours 59 minutes 59 seconds.

4 . Single event sound exposure level (L_{Ae}) and Percentile level (L_x) measurement

When measuring LAeq or LAe, the following automatically starts by pressing the **Start** key.

- Equivalent continuous A-weighted sound pressure level : LAeq
- Single event sound exposure level : LAe
- Percentile level : L₀₅ , L₁₀ , L₅₀ , L₉₀ , L₉₅ , L_{min} or L_{max}

LAeq can be displayed in **Normal display mode**, but LAe or L_x are displayed only in **List display mode**.

→ E	00h 000h00m00s
FAST	
Lap : 140.0dB	La05:140.0dB
Laeq : 140.0dB	La10:140.0dB
Lae : 140.0dB	La50:140.0dB
LMin : 140.0dB	La90:140.0dB
LMax : 140.0dB	La95:140.0dB
<input type="checkbox"/> Manu	dB

5. Max Hold Measurement

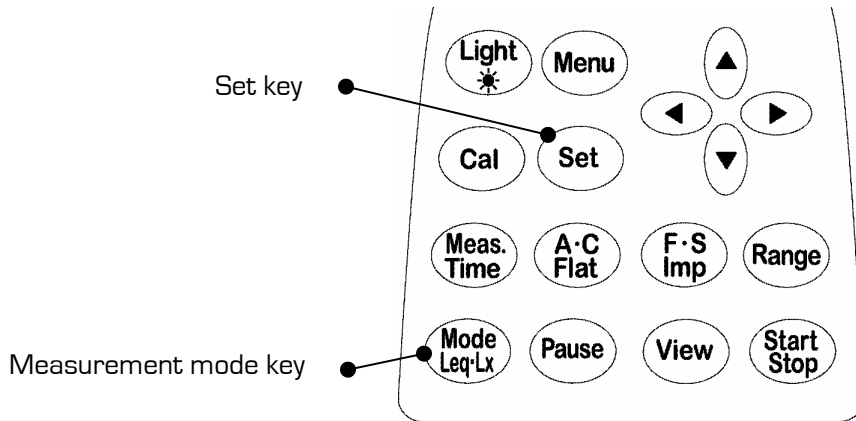

< Parameter settings >

Measurement mode key : MH

< Display >

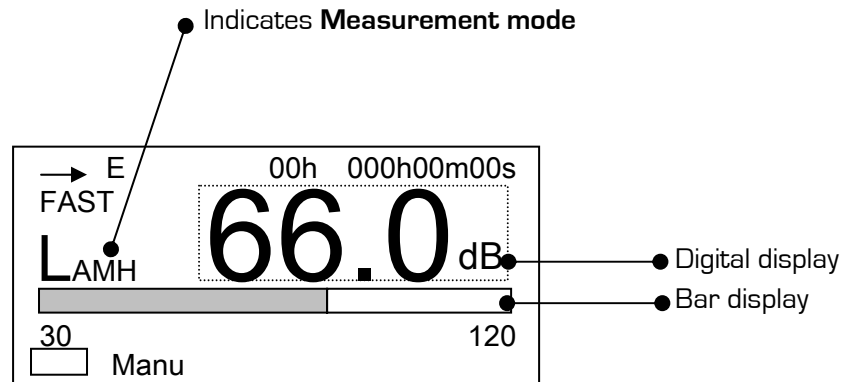

- After pressing the **Set** key, the digital display holds its maximum value and is only updated when a new maximum value is measured.
- Pressing the **Set** key resets the MH value.
- The bar display does not hold its value, but shows an instantaneous value updated every 0.1 seconds.

6. C-weighted waveform peak hold measurement (LC_{Peak})

Lc_{peak} is measured on "Peak measurement" setting.

Change the basic setting from Manu [default] to Peak.

[1] Press Menu key once to call <Menu>1/2 screen and check the cursor is on the top line of "Meas Mode".

[2] Move to the right column with  key.

[3] Change "Manu" to "Peak" with  key and press the **SET** key to enter.

[4] Return to the normal display from <Menu> screen by pressing the **View** key and check the display shows Peak under the figures.

< Parameter setting >

Range key: Select a range that Bar display indicates approximately 2/3 of the full scale.

Time weighting key: N/A

Frequency weighting key: C

Measurement time key: 1s, 3s, 5s, 10s, 1m, 5m, 10m, 15m, 30m, 1h, 8h, 24h, and * * *.

[* * * : Measurement continues until **Stop** key is pressed.]

Measurement mode key: N/A (fixed to LC_{pk})

< Display >

<Mode Set> screen [for example]

<menu>		1/2	③
Meas Mode	: Peak	←	
Interval	: Single		
I/O	: Off		
Data delet	: Off		
LCD cont	: * * * *		
date y/m/d	: 02/04/19		
time	: 11: 16: 58		

Normal display mode screen

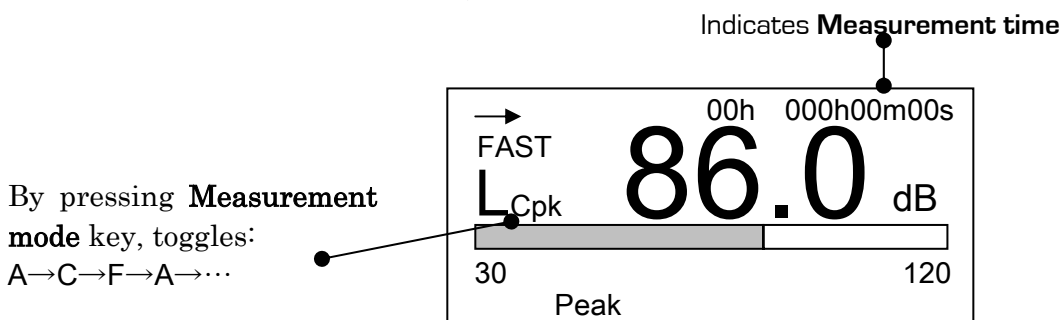

- Measurement starts by pressing the **Start** key and automatically stops in the measurement time (→ is displayed during measurement). The display indicates the calculated data at that time.
- If the **Stop** key is pressed during measurement, the display indicates the calculated data at that time.
- When * * * is selected, the display indicates the calculated data at the time the Stop key is pressed. If the Stop key is not pressed, the measurement continues for 199 hours 59 minutes 59 seconds.

Section 4 Menu

1. How to use Menu

To open the Menu display press the **Menu** key.

Return to the measurement display by pressing the **View** key.

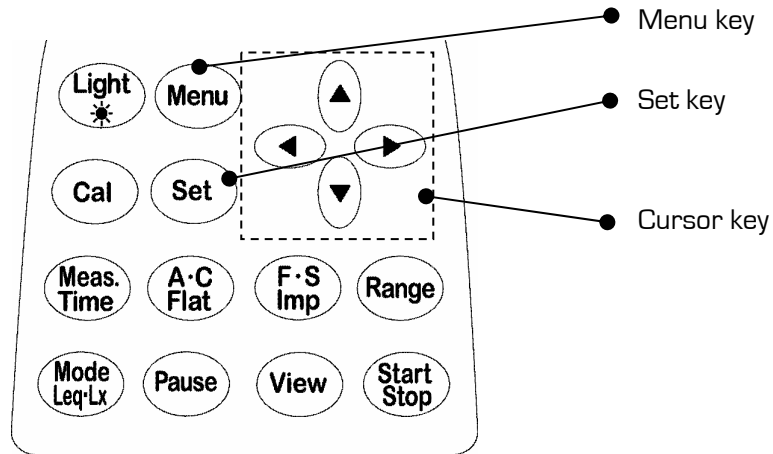

Every time the **Menu** key is pressed, <menu> and <Mode Set> pages are alternated.

Select an item with ▲ ▼ key and complete the selection with ► key, then change the parameters with ▲ key.

<menu>	1/2
Meas Mode	: Manu
Interval	: Single
I/O	: OFF
Data delet	: OFF
LCD cont	: *****
date y/m/d	: 00/01/01
time	: 00:00:00

Basic setting for Calendar, LCD contrast etc.

<Mode Set>	2/2
Range	: 130dB
Dyn cher	: FAST
Freq corr	: A
Meas time	: 1s
View	: L05
baud rate	: 9600

Setting for measurement modes.

2. Menu (1/2)

<menu>	1/2	●—●Page of Menu
Meas Mode	: Manu	
Interval	: Single	
I/O	: OFF	
Data delet	: OFF	
LCD cont	: *****	
date y/m/d	: 00/01/01	
time	: 00:00:00	

<u>Items</u>	<u>Initial value</u>	<u>Explanation</u>
• Meas Mode	: Manu	: Measurement mode Manu : Normal measurement mode
• Interval	: Single	: Measuring interval OFF : Continuous data output mode. Single : Completes one measurement in Meas Time by pressing Start key. Repeat : Repeats measurement in every Meas Time by pressing Start key. Measurement is repeated until Stop key is pressed.
• I/O	: OFF	: External equipment connection setting OFF : No external equipment. Print : Enables an external printer to be used. PC : Enables a personal computer to be used.
• Data delet	: OFF	: Data deletion mode setting OFF : No Data deletion mode 3sec : deletes preceding 3 sec. data when Pause key is pressed. 5sec : deletes preceding 5 sec. data when Pause key is pressed. When Meas Time is 1, 3 or 5s, this function does not work.
• LCD cont	: *****	: LCD contrast adjustment. See "LCD adjustment".
• date y/m/d	: 00/01/01	: Calendar setting (indicates year/month/day) See "Calendar adjustment".
• time	: 00:00:00	: Time setting See "Calendar adjustment".

3 . Mode Set (2/2)

<Mode Set>	2/2
Range	: 130dB
Dyn char	: FAST
Freq corr	: A
Meas time	: 1s
View	: L05
baud rate	: 9600

- Range : 130dB : Shows a range value set with the **Range** key.
 - Dyn char : FAST : FAST , SLOW or Imp
Shows Time weighting set with the **F · S · Imp** key.
 - Freq corr : A : Shows Frequency weighting set with the **A · C · Flat** key.
 - Meas time : 1s : Shows Measurement time set with the **Meas time** key.
 - View : L05 : Mode setting in Normal and Magnified display mode.
Sets the value displayed in Normal and Magnified screen.
 - baud rate : 9600 : Baud rate setting
4800, 9600 or 19200.
-
- The contents are updated every time the settings are changed.
 - The Range etc. can be changed in this menu.

Section 5 AC, DC Output

1. AC Output

The AC Output is the frequency-weighted signal.

Output: 1Vrms (Full Scale), Output impedance: 600Ω, Load impedance > 10kΩ

2. DC Output

The DC Output is a frequency weighted, root mean squared, and then logarithmically converted signal.

Output: 2.5V (Full Scale), 0.25V/10dB, Output impedance: 50Ω, Load impedance > 10kΩ

Section 6 Printing

After measurement is completed, the results can be printed with an optional printer.
(Results can not be printed during measurement.)

<menu>	1/2
Meas Mode	: Manu
Interval	: Single
I/O	: OFF
Data delet	: OFF
LCD cont	: *****
date y/m/d	: 00/01/01
time	: 00:00:00

The procedure is as follows.

- 1) Turn off the POWER switch.
- 2) Connect to a printer and turn on the POWER switch. The version is automatically printed when powered on.
- 3) Ensure the Baud Rate is set the same on the 6224 as the printer [See section 4, No 3. Mode Set 2/2 on page 24]. See separate Printer manual for setting the baud rate of the printer.
- 4) Select **I/O** in Menu display.
- 5) Select **Print**, then press the **Set** key.

The display shows as follows:

Print Start/Stop key

- 6) All data is printed by pressing the **Start** key.
Printing is stopped by pressing the **Stop** key.
- 7) After completion of the data transfer to a printer, the display returns to **Menu** automatically.

<Printout form >

Example	Explanation
00/01/05 2:15:16 F 130dB	Starting date and time, Time weighting and Range
000h00m10s	Measurement time
Laeq : 130.0 La05 : 130.0	data
Lae : 130.0 La10 : 130.0	''
La50 : 130.0	''
LMin : 130.0 La90 : 130.0	''
LMax : 130.0 La95 : 130.0	''

Starting date and time, Time weighting and Range are printed on the first line.

Measurement time is printed on the second line.

Data is printed on the third to seventh line.

When the **Interval** is set to **Repeat** in the **Menu** display, the results of every **MeasTime** are printed in the above form.

Measurement is stopped by pressing the **Stop** key, data is printed as * * *.

Section 7 Data Transfer to a Personal Computer

After or during measurement, the data can be transferred to a personal computer.

1) Data transfer after measurement

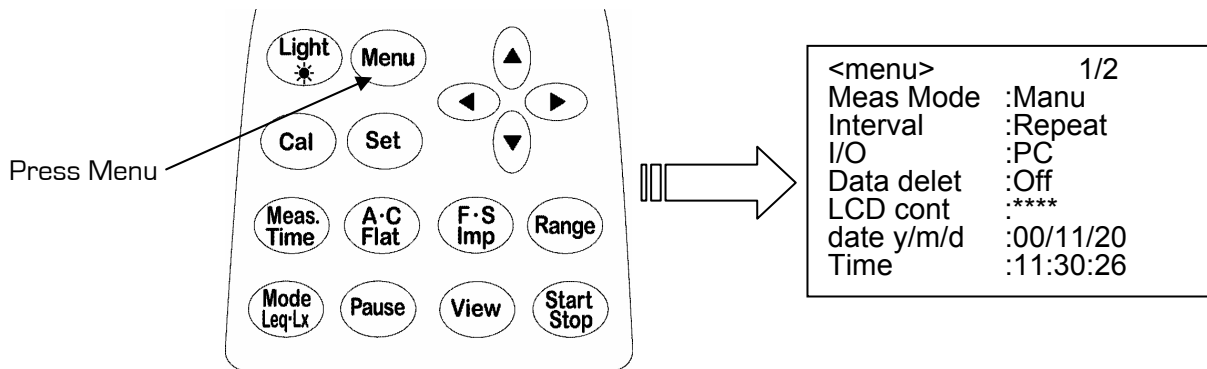

The procedure is as follows.

- 8) Turn off the POWER switch.
- 9) Connect to a PC using the cable and turn on the POWER switch.
- 1 0) Press the **Menu** key and select **I/O** in the Menu display.
- 1 1) Select **PC**, then press the **Set** key.

The display shows as follows:

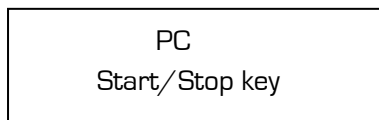

- 1 2) All data is transferred by pressing the **Start** key.
Data transfer is stopped by pressing the **Stop** key.
- 6) After completion of the data transfer, the display returns to **Menu** automatically.

The data is saved in .csv format so it can be opened directly with spreadsheet software e.g. Microsoft Excel.

2) Data transfer during measurement

Data can be transferred to a PC during measurement in real-time by taking the following steps. Please note that in this mode the data can not be saved to memory in the instrument and should instead be saved on the PC as described later in this manual.

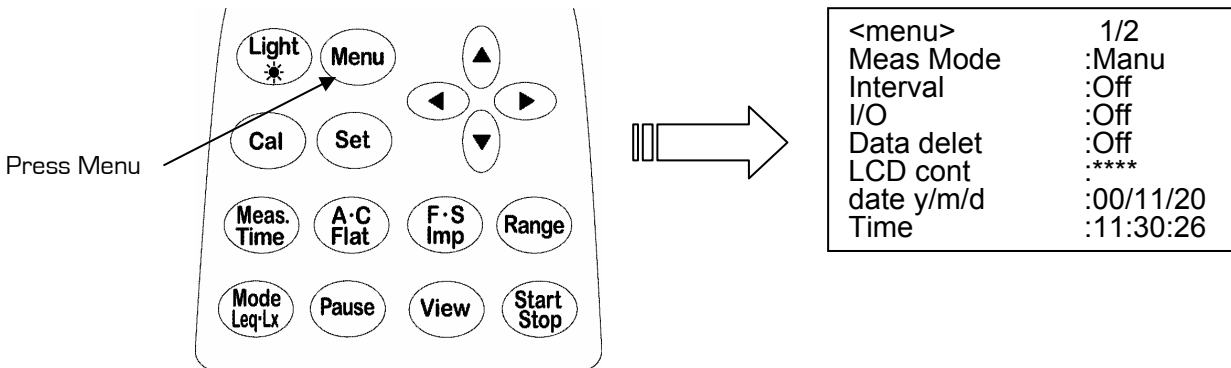

- 1) Turn off the POWER switch.
- 2) Connect to a PC using the cable and turn on the POWER switch.
- 3) Press the **Menu** key and select **Interval** in the Menu display.
- 4) Select **Off**.
- 5) Still in the Menu display, select **I/O**.
- 6) Select **Off**, then press the **Set** key.
- 7) Press View, and the measurements screen appears

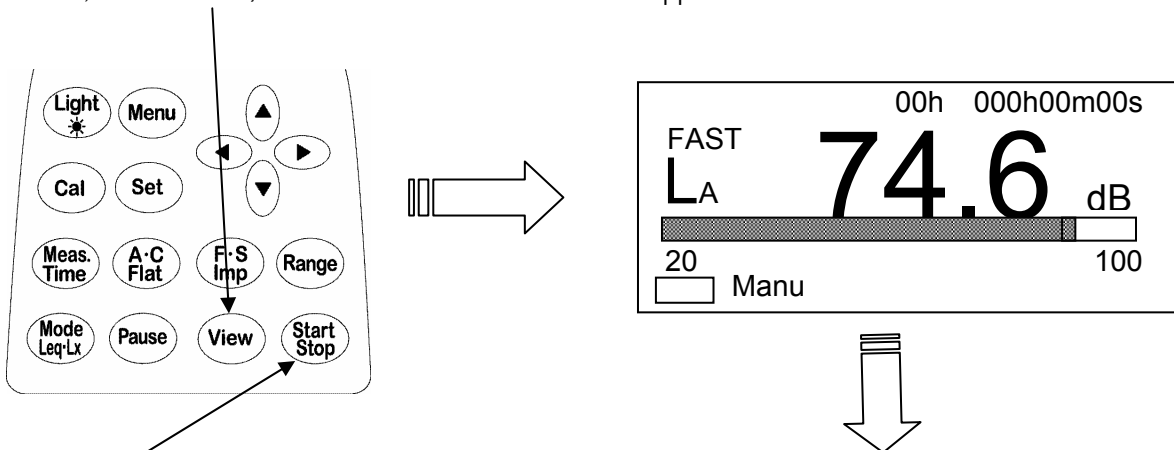

- 6) Press Start/Stop, measurements begin and data is transmitted for each measurement interval. The data is appended to data displayed on the PC screen.
- 7) Press Start/Stop again to stop measurements and transmission.

Remember: Transmitted data is not stored in the memory of the sound-level meter. After transmission be sure to save it on the PC as described on page 21.

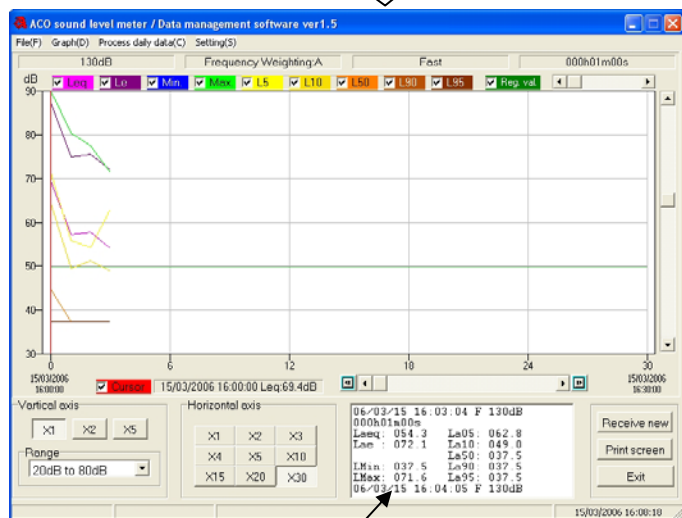

Received data is displayed in this window.

Section 8 Specifications

Model	Castle 6224
Description	Precision Integrating Sound Level Meter
Standards	Conforms with IEC 61672-1:2002, Class 1, IEC 60651:1979 and IEC 60804:2000 Type 1
Measuring ranges	27 - 130dB(A), 38 - 130dB(C), 41 - 130dB(F)
Frequency range	20Hz - 20kHz
Microphone	7146N 1/2" electret condenser microphone
Time weighting	FAST, SLOW, IMPULSE
Peak range	50 - 133dB(A), 60 - 133dB(C), 70 - 133dB(F)
Level range	Six ranges: 20 - 80dB, 20 - 90dB, 20 - 100dB, 20 - 110dB, 30 - 120dB, 40 - 130dB
Linearity range	90dB
Frequency weighting	A, C, FLAT (Z)
Measurement items	Lp, LMH, Leq, LAe, Lmax, Lmin, Lx (L5, L10, L50, L90, L95), Peak.
Measurement time	1s, 3s, 5s, 10s, 1min, 5min, 10min, 15min, 30min, 1h, 8h, 24h manual (max: 199h 59m 59s)
Sampling interval	20.8 μ s (Leq), 10ms (Lmax, Lmin)
Lx Sampling interval	100ms
Display	LCD with backlight (128 \times 64 dots)
Digital display	Four line, resolution 0.1dB (display update 1s)
Bar display	Display update: 0.1s
Warning	Over range: +3dB from upper limited scale Under range: -0.6dB from lower limited scale
Battery display	Four level display of battery condition
Built-in memory	Approximately 10, 000 samples: 1, 000 sets of results
Built-in calendar	Year/month/day/ hour : minute : second
Pause	Pause and a function that deletes preceding 3 or 5 sec. data
Calibration signal	Internal generator (1 kHz sine wave)
AC output	1Vrms (FS), output impedance: 600 Ω , load impedance > 10k Ω
DC output	2.5V (FS), 0.25V/10dB, output impedance: 50 Ω , load impedance > 10k Ω
RS232 interface	RS-232C (asynchronous) data bits : 8 bits stop bit : 1 bit parity : none baud rate : 4800, 9600, 19200 bps
Power supply	Four 1.5V size-AA batteries or AC adapter
Battery life	Alkaline batteries: 20 hours continuous operation. Use of LCD backlight will shorten battery life (approximately 1/3).
Operating temperature	-10 to +50 $^{\circ}$ C
Humidity	25% to 90% (without condensation)
Size	85(W) \times 287(H) \times 46(D) mm
Weight	370g (including batteries)

Pin Connections and How to Connect the Extension cable

1. Detach the microphone from the body of the meter.

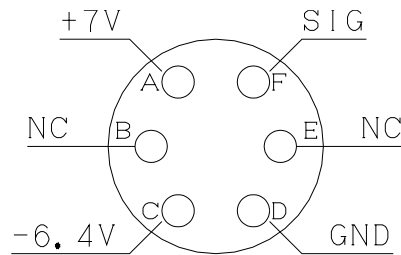
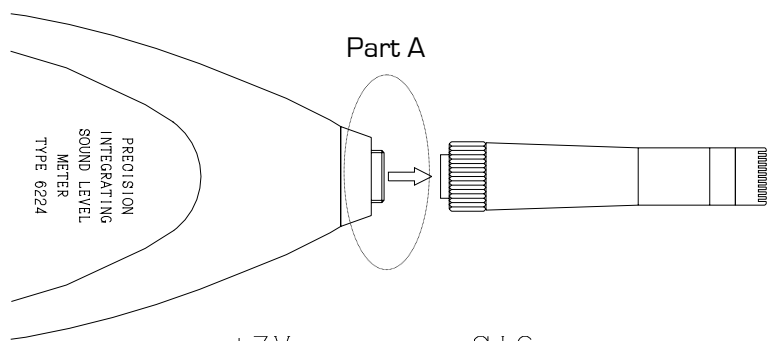
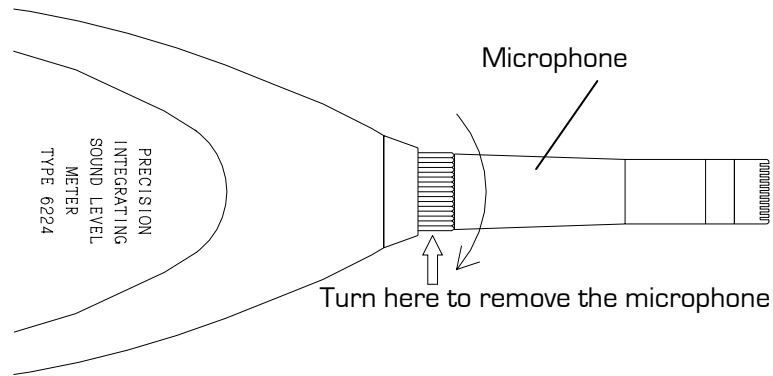

Pin connections of Part A

2. Attach the microphone to the female connector of the extension cable.
3. Plug the male connector of the extension cable into the connector on the body of the instrument.