



***Tremetrics RA500
Advanced Microprocessor Audiometer
Operation Manual***

P/N 78460

Revision M
January 1999

Information disclosed herein may not be reproduced in any
form without the express permission of TREMETRICS
Copyright © 1994, 1999 TREMETRICS



Standard Warranty

Tremometrics "Seller", warrants the goods sold will conform with all pertinent specifications including performance specifications, drawings and approved samples, as furnished.

Seller also warrants said goods to free of defective materials and workmanship.

This warranty is in lieu of all warranties, express or implied. SELLER MAKES NO WARRANTY THAT SAID GOODS ARE FIT FOR ANY PARTICULAR PURPOSE, NOR ANY WARRANTY AS TO THE MERCHANTABILITY OR QUALITY OF GOODS SOLD EXCEPT AS HEREIN STATED.

All claims for alleged defects of goods under this warranty shall be deemed waived unless made in writing and delivered to Seller within twelve (12) months after date of shipment, unless otherwise specified hereinbelow, and on any such claims, Seller has the option of inspecting the goods claimed defective at the Buyer's place of business or having them returned to Seller for inspection.

Instrument parts which have been repaired or replaced during the warranty period are themselves warranted only for the remaining unexpired portion of the original warranty.

This warranty shall not apply where goods have been subject to misuse, neglect, accident or improper application or have been repaired or substantially altered by others, nor does this warranty apply to items consumed in the ordinary course of use of the goods, such as, but not limited to, fuses or batteries. This warranty shall not apply to calibration of the earphone transducers, which is subject to change through normal use.

EXCEPT AS EXPRESSLY PROVIDED HEREIN, SELLER MAKES NO OTHER WARRANTIES, EITHER EXPRESSED OR IMPLIED, INCLUDING WITHOUT LIMITATION, ANY IMPLIED WARRANTIES OF MERCHANTABILITY AND/OR FITNESS FOR ANY PARTICULAR PURPOSE.

Transportation charges covering returned goods will be borne by Buyer. No returns will be accepted unless authorized by Seller.

SELLER'S LIABILITY SHALL BE LIMITED TO SELLER'S STATED SELLING PRICE PER UNIT OF ANY DEFECTIVE GOODS AND SHALL IN NO EVENT INCLUDE BUYER'S MANUFACTURING COST, LOST PROFITS, GOOD WILL OR ANY OTHER SPECIAL OR CONSEQUENTIAL DAMAGES. Seller may, at its discretion, repair with new or factory refurbished parts, replace, or give Buyer credit for, such defective items.

DAMAGE LIMITATIONS: NOTWITHSTANDING ANYTHING ELSE TO THE CONTRARY HEREIN, SELLER'S LIABILITY, (WHETHER BY REASON OF BREACH OF WARRANTY, BREACH OF CONTRACT, TORT, OR OTHERWISE AND IRRESPECTIVE OF SELLER'S NEGLIGENCE) SHALL IN NO EVENT EXCEED THE PAYMENT, IF ANY RECEIVED BY SELLER FOR THE PRODUCT OR PART FURNISHED OR TO BE FURNISHES, AS THE CASE MAY BE, WHICH IS THE SUBJECT OF THE CLAIM OR DISPUTE.

Items produced by third party manufacturers shall carry that warranty proved to Seller by said third party manufacturers. Such warranty shall be passed by Seller to the Buyer.

CHOICE OF LAWS: THIS WARRANTY SHALL BE GOVERNED BY THE LAWS OF THE STATE OF TEXAS, WITH VENUE OF LITIGATION IN AUSTIN, TRAVIS COUNTY, TEXAS.

Screening Audiometer

This pure tone air conduction Audiometer manufactured by TREMETRICS was designed primarily for use in determining hearing threshold levels in comparison with standard reference threshold levels. The Audiometer is a screening device that if properly operated, maintained, and calibrated will allow the operator to screen subjects for shifts in hearing acuity. The Audiometer is used to record the subject's current threshold, which may be affected from day to day by noise exposure, colds, sinus infections, or other problems.

Testing, as referred to in this manual, is the screening procedure used to establish thresholds (hearing levels) and is in no way trying to diagnose, monitor, or treat any medical problem, disease or injury. If a problem is suspected, the subject should be referred to an audiologist or medical doctor for evaluation.

The audiograms obtained from this screening procedure provide a way for records to be maintained for the subject and for the company where the subject works, in order that an audiologist or medical doctor may more fully evaluate and prevent major hearing problems.

To guarantee accuracy, each audiometer must be recalibrated at least once each year and receive an exhaustive calibration every two years. Daily biological tests through the use of an Electro-Acoustic Ear (for daily comparisons to acoustic ear baseline obtained at time of calibration) and the operator listening to each frequency and verifying the attenuator operation insures accuracy and purity of the audiometer tones.

Table of Contents

<i>Section</i>	<i>Description</i>	<i>Page #</i>
Section I	Introducing the RA500	1-1
Section II	How to Customize Your RA500	2-1
	2- 1 Option 1 - Enter Date	2-3
	2- 2 Option 2 - Enter Time	2-3
	2- 3 Option 3 - Company Time	2-3
	2- 4 Option 4 - Select/Delete Questions	2-4
	2- 5 Option 5 - Enter Questions	2-4
	2- 6 Option 6 - Set Baud Rate	2-5
	2- 7 Option 7 - Select/Delete Frequencies	2-5
	2- 8 Option 8 - Select PBI Calculations	2-5
	2- 9 Option 9 - Set Beep Tone Level	2-6
	2- 10 Option 10 - Select Pulse/Continuous	2-6
	2- 11 Option 11 - Select Beep Response for Keyboard	2-6
	2- 12 Option 12 - Select Top Test Level	2-6
	2- 13 Option 13 - Select Bottom Test Level	2-7
	2- 14 Option 14 - Select Beep at Test Complete	2-7
	2- 15 Option 15 - Enter Password for Security	2-7
	2- 16 Option 16 - Select Bar Graph Print of Audiogram	2-8
	2- 17 Option 17 - Select Raw Data Dump to Print	2-8
	2- 18 Option 18 - Set Default System Configuration	2-9
	2- 19 Option 19 - Select Audio Print at Test Complete	2-9
	2- 20 Option 20 - Set Talk-Over Output Level	2-9
	2- 21 Option 21 - Select Test the Right Ear First	2-9
	2- 22 Option 22 - Enter Communications Password	2-9
	2- 23 Option 23 - Enter Communication User ID	2-10
	2- 24 Option 24 - Enter Communication Phone Number	2-10
	2- 25 Option 25 - Enter Auto-Transmit Time	2-10
	2- 26 Option 26 - Communication Monitor Mode	2-11
	2- 27 Option 27 - Select STS/Categorization	2-11
	2- 28 Option 28 - Select Quick Screen Mode	2-12
	2- 29 Option 29 - Set Maximum Failed Frequencies	2-13
	2- 30 Option 30 - Select Auto Tag in Store Test	2-14
	2- 31 Option 31 - Select Tagged Transfer Data	2-14
	2- 32 Option 32 - Enable/Disable Adaptive Mode	2-14
	2- 33 Option 33 - Select Flow Gemini Comm Mode	2-15
Section III	Explanation of Custom Specials in Your RA500	3-1
	3- 1 Special 01 - Calibration Mode	3-1
	3- 2 Special 02 - Clear and Reset Entered Questions	3-1
	3- 3 Special 03 - Printer Test	3-1
	3- 4 Special 04 - Serial Port Test	3-1,
	3- 5 Special 05 - Delete Data From Storage Menu	3-2
	3- 6 Special 06 - Accelerated Listening Check	3-3
	3- 7 Special 07 - Change Test Type	3-3
	3- 8 Special 08 - Recall Test From Storage	3-4
	3- 9 Special 09 - Display Storage Memory Remaining	3-4
	3- 10 Special 10 - EPROM Error Test	3-5
	3- 11 Special 11 - RAM Error Test	3-5

<i>Section</i>	<i>Description</i>	<i>Page #</i>
	3- 12 Special 12 - Keyboard Test	3-5
	3- 13 Special 13 - Enter/Store Multiple Baselines	3-5
	3- 14 Special 14 - Tag Records for Transfer	3-7
Section IV	What Are the Functions of the Keys on my RA500 Keyboard.... and What Do They Do	4-1
	4- 1 Group 1 - Supplemental Keys	4-1
	4- 2 Group 2 - Function Keys	4-4
	4- 3 Group 3 - Print Keys	4-5
	4- 4 01 - Print Patient IDs For All Records	4-5
	4- 5 02 - Print Test IDs For All Records	4-5
	4- 6 03 - Print Patient IDs For All BL Records	4-5
	4- 7 04 - Print Patient IDs For All Non BL Records	4-5
	4- 8 05 - Print All Test IDs For a Patient ID	4-5
	4- 9 06 - Print Bar Graph of Current Audiograms	4-6
	4- 10 07 - Print Raw Data For Current Audiograms	4-6
	4- 11 08 - Print Unit Configuration	4-6
	4- 12 Group 4 - Command Keys	4-6
	4- 13 Group 5 - The Number Keys	4-7
Section V	How to Conduct an Automatic Audiometric Test with Your RA500	5-1
	5- 1 How to Do a Manual Test with Your RA500	5-4
	5- 2 How to Do an Audiometric Test in the Semi-Automatic Mode	5-5
Section VI	Loading Paper in Your RA500	6-1
Section VII	Error Codes	7-1, 7-2
Section VIII	Factory Default System Configuration	8-1
Section IX	Interfacing to PC	9-1 - 9- 3
Section X	Operation with Tremetrics AR9S Soundroom	10-1
Section XI	What to Do If Something Goes Wrong	11-1

Introducing the RA500 Section I

Congratulations! You are the new owner of the advanced microprocessor screening audiometer - the RA500 or the RA500 *Plus*. For purposes of simplicity, both audiometers types will be referred to as the RA500. The RA500 *Plus* differences will be marked with +++.

Building upon the successful track record of its predecessor, the RA400, your new unit possesses many new and unique features. The following is a list of some of the new features:

- A. Easy to read liquid crystal module screen.
- B. High quality graphics and quiet text printer.
- C. Alpha numeric keyboard for custom entry of patient questions.
- D. Download/upload audiogram transfer capability.
- E. Customization of many testing functions.
- F. Memory/Storage for up to 400 audiograms. (+++ 1200 for the RA500 *Plus*)
- G. Automatic baseline retrieval.
- H. Multiple baseline entry and storage.
- I. Printout of unit configuration.

This instruction manual is divided into several parts. It is written to allow you to set up your RA500 and use it in as short as time as possible. The sections are:

Section I	Introducing the RA500
Section II	Customizing Your Audiometer
Section III	Explanation of Custom "Specials" in the RA500
Section IV	Functions of Keyboard Keys
Section V	How to Conduct an Automatic Audiometric Test
Section VI	Loading Paper in Your RA500
Section VII	Explanation of Error Codes
Section VIII	Factory Default System Configuration
Section IX	Interfacing to PC
Section X	Operation with Tremetrics AR9S Soundroom
Section XI	What to Do If Something Goes Wrong

You will probably notice that "The Running of a Test" section appears late in the manual. This is done for several reasons. The RA500 is a highly

sophisticated instrument that is surprisingly easy to use. To take full advantage of its power and flexibility, you have to know how to customize its features to your personal requirements. By doing this once (or any time you want to change your set-up) you will be able to understand how to receive the maximum benefits from your instrument.

However, we realize that some of you may want to jump right in and start to use your new audiometer. If that's the case, go to Section V for an explanation on how to perform an audiometric test. If you wish, you can customize your instrument later by following the appropriate sections of this manual, in order.

One last note, there is no substitute in learning how to use the RA500 than to simply - use it! The more you use your RA500, the more proficient you will become. Few people become proficient using sophisticated instruments by just reading the manual. You can certainly use the manual for reference, and we encourage you to do so if needed. However, simply using your RA500 is the best tutorial you have.

Let's go to **Section II** and take a look at how you can custom tailor your new RA500 audiometer to your needs.

NOTE: The RA500 requires power connection to either 120 volts AC +/- 10%, 60 Hz or 240 volts AC +/- 10%, 50 Hz. The power receptacle and power cord should be marked "Hospital Grade", or "Hospital Grade Only" to comply with safety regulations. The handswitch and earphones should be firmly seated into the indicated jacks on the rear panel of the audiometer. Be sure that the serial number of your earphones matches that of the audiometer.

**How to Customize Your RA500
Section II**

The technical sophistication of your RA500 will allow you to uniquely customize its features and tests. It also allows you to have features that formerly required custom factory programming -- at no additional cost. And remember, once you have been through the custom initialization, your requirements are permanently saved even when the unit is turned off.

Let's get started. Turn your RA500 on from the switch at the back panel. After a couple of seconds your screen should look like this.

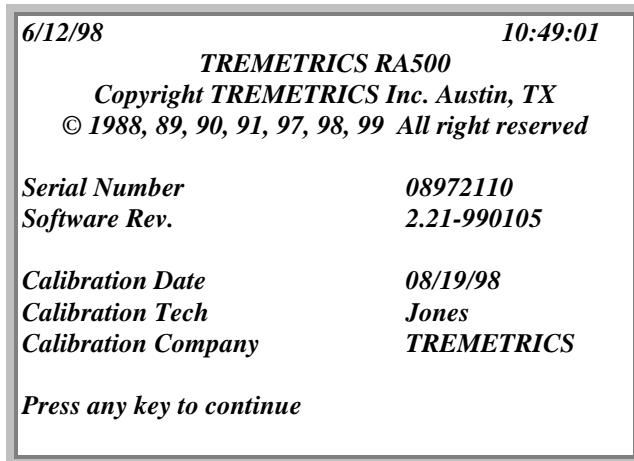

Figure 2-1 RA500 Turn-On Display Screen

You will notice at the bottom, it says "PRESS ANY KEY TO CONTINUE". After you have done this, the RA500 test screen will be displayed. It should look like this.

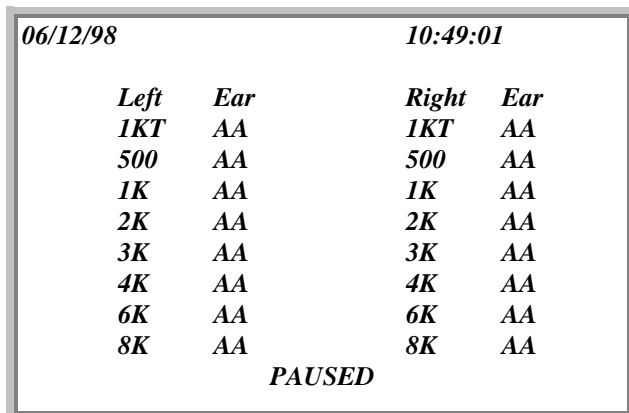

Figure 2-2 RA500 Main Test Screen

Since you are not ready to test yet (remember we are going to "set-up" and initialize the RA500 first) we will ignore this display for right now. Look for the key marked [SET UP] in the upper left corner under the [A] key. Press it, and you should see the set-up screen as shown below:

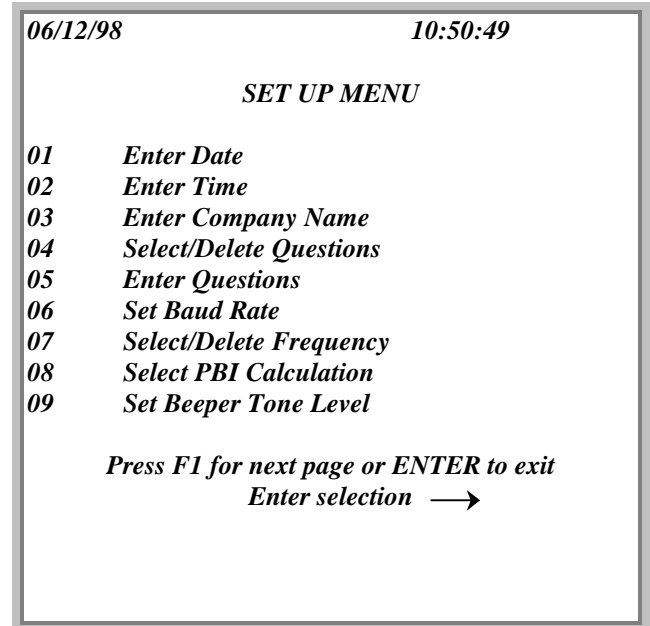

Figure 2-3 "SET-UP" Menu

The set-up functions on the first page are:

1. Enter Date
2. Enter Time
3. Enter Company Name
4. Select/Delete Questions
5. Enter Questions
6. Set Baud Rate
7. Select/Delete Frequency
8. Select PBI Calculation
9. Set Beeper Tone Level

You will notice the message at the bottom that says: "PRESS F1 FOR NEXT PAGE"

Go ahead and press [F1] to continue.

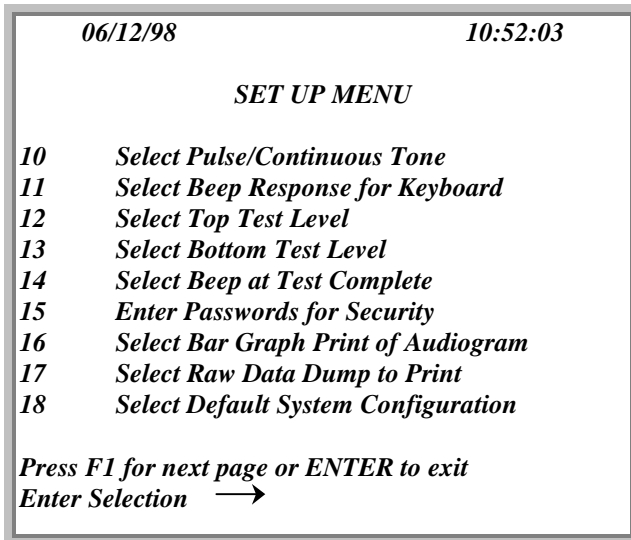

Figure 2-4 Second Page of Set-Up Menu

The set-up items on page 2 are:

- 10. Select Pulse/Continuous Tone
- 11. Select Beep Response for Keyboard
- 12. Select Top Test Level
- 13. Select Bottom Test Level
- 14. Select Beep at Test Complete
- 15. Enter Passwords for Security
- 16. Select Bar Graph Print of Audiogram
- 17. Select Raw Data Dump to Print
- 18. Select Default System Configuration

From here, press [F1] again and you will see additional options.

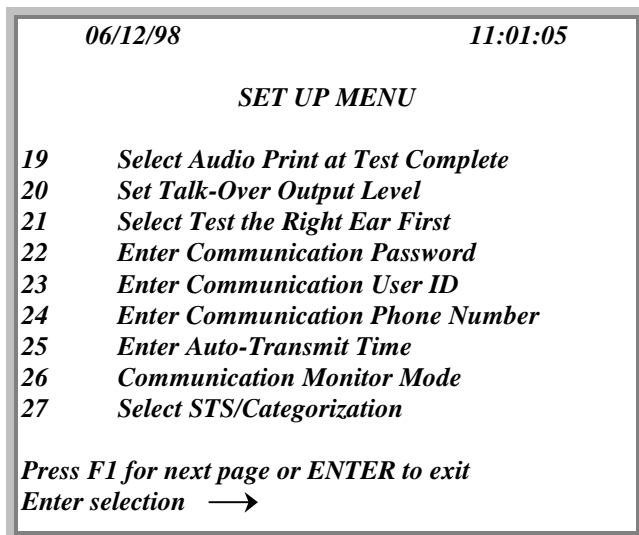

Figure 2-5 Third Page of Set-Up

- 19. Select Audio Print at Test Complete
- 20. Set Talk-Over Output Level
- 21. Select Test the Right Ear First
- 22. Enter Communication Password
- 23. Enter Communication User ID
- 24. Enter Communication Phone Number
- 25. Enter Auto-Transmit Time
- 26. Communication Monitor Mode
- 27. Select STS/Categorization

From here, press [F1] again and you will see the remaining options.

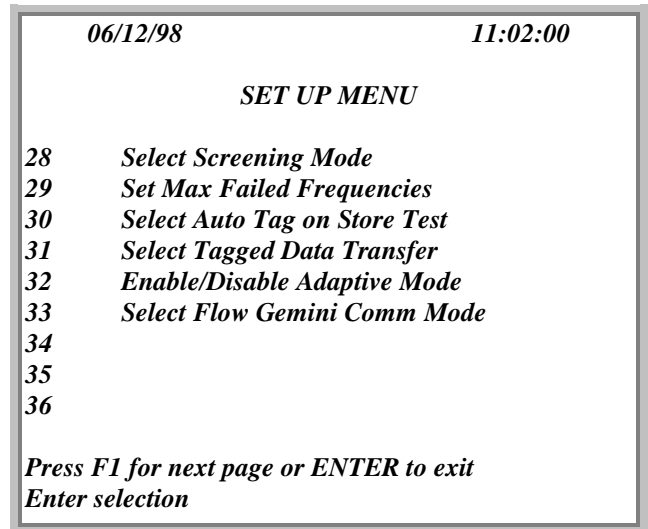

Figure 2-5A Fourth Page of Set-Up Menu

- 28. Select Screening Mode
- 29. Set Max Failed Frequencies
- 30. Select Auto Tag on Store Test
- 31. Select Tagged Data Transfer
- 32. Enable/Disable Adaptive Mode
- 33. Select Flow Gemini Comm Mode

Now that you know what your initial set-up options are, we'll go through them one by one and initialize your RA500.

In each set-up option, you must remember to press the numeric key to reach that particular option. For example, if you are in the set-up menu display (**Figure 2-3, 2-4 or 2-5**), and you want to change PBI calculations (option 08) press [0], [8] and [ENTER]. **You do not need to be in any particular set-up menu page to reach any particular option.** For example, if you are in set-up menu display #2 (see **Figure 2-4**) and you want to go to option #3 (company name) -- simply press [0], [3] and

[ENTER]. You will reach the option without being on the page listing that option. Remember, press the set-up menu number (both numbers if nine or below, i.e. [0], [9] or [0], [4] and [ENTER] to reach that set-up option.

2-1 OPTION 1 - Enter Date

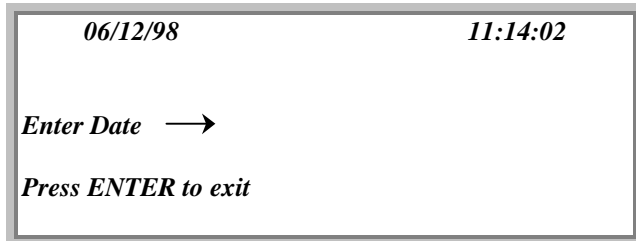

Figure 2-6 Enter Date

Press [0] and [1] and [Enter] to reach the Enter Date menu, then enter the date as directed. It is not necessary to put in the "/" marks; they are entered automatically. Press the number keys and you will see the numbers displayed on the screen in the spaces provided. One thing to remember -- it does not take a lot of pressure to make the key switch contact. From the "tactile feel" of the keyboard, you will feel the contact being made.

Let's say you wanted to enter 4/21/98. You press [0], [4], [2], [3], [9], [8] (oops!). You want 4-21, not 4-23. Do you see the [CLEAR] key on the far upper right corner? Each press will backspace and erase whatever is in its path. You can also use the shift key (that means press the [SHIFT] key and hold it down) while you press the [←] key. This will backspace **without** erasing. When you have the correct date in the space provided, press the [ENTER] key at the lower right hand corner of the keyboard. The correct date will be set and you will find yourself back at the set-up window.

2-2 OPTION 2- Enter Time



Figure 2-7 Enter Time

Press [0], [2] and [ENTER] to reach the Enter Time menu. Entering the correct time is just a matter of pressing the appropriate number keys. When your

time is correct, press [ENTER] to go back to the main set-up menu. You will notice that you now have the correct date and time displayed at the very top of the screen.

2-3 OPTION 3 - Company Name

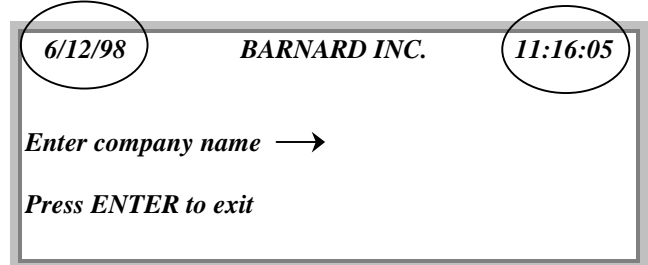

Figure 2-8 Enter Company Name

In the past, if you ever wanted to customize your audiometer with your company name, it required custom programming (and additional cost) by the factory. No longer! With your new RA500, **you** can enter any name or number up to 16 characters. The company name will appear at the initial turn-on screen, test screen and on your printout!

Entering the company name on your RA500 will involve a brief explanation of how to use the alpha (or letter) keys on the keyboard.

Press [0], [3] and [ENTER] to reach the Company Name Menu. To enter your company name, just press the letter keys on the keyboard. You will see each letter entered on the display as the key is pressed. Remember, if you make a mistake, use the [CLEAR] key to go back and correct the error, or use the [SHIFT] and [←] key to go back without erasing your existing title. Press [ENTER] to exit.

2-4 OPTION 4 - Select/Delete Questions

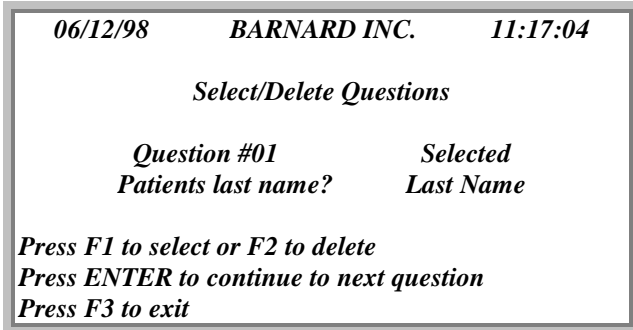

Figure 2-9 Select/Delete Questions

Press [0], [4] and [ENTER] to reach the Select/Delete questions menu. This set-up option allows you to select or delete any questions previously entered in your RA500. Just follow the screen prompts and press [F1] or [F2] key to enable or disable when asked about a particular question. You can press the F3 key at any time to return to the main set-up window.

Once you have either selected or deleted the questions, they will stay permanently in memory until you change them.

You can delete the questions from your data entry routine and restore them later. Just go back to option #4, go through each display and re-enable your deleted questions.

2-5 OPTION 5 - Enter Questions

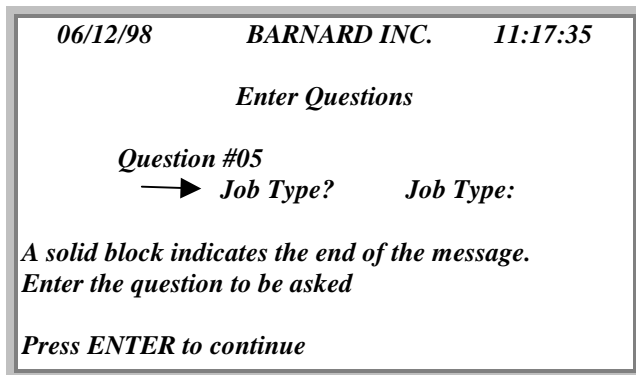

Figure 2-10 Enter Questions

You can enter patient questions and program the desired space for their answers with option # 05. You will note that this option starts with question #05. That is because there are four questions that are programmed at the factory. They are required to

automatically calculate answers (such as Presbycusis).

Press [0], [5] and [ENTER] to reach the Enter Question menu. The first thing to do is enter the question to be asked. Use the letter, or alpha keys from the left four groups on the keyboard. Letters are positioned in the upper left part of the keyboard. Let's enter the question -- "Job Type?", as in the example in Figure 2-10. Just type the following -- [J], [O], [B] [SHIFT/SPACE] (this means you press the shift key and hold it down while pressing the space key), [T], [Y], [P], [E], [SHIFT/"?"], (again to type the question mark, you press the [SHIFT] key and hold it down while you press the [?] key). You have shifted this key to enable the question mark to be printed.

Once you have typed the question, press the [ENTER] key. You will notice that the screen now displays the following:

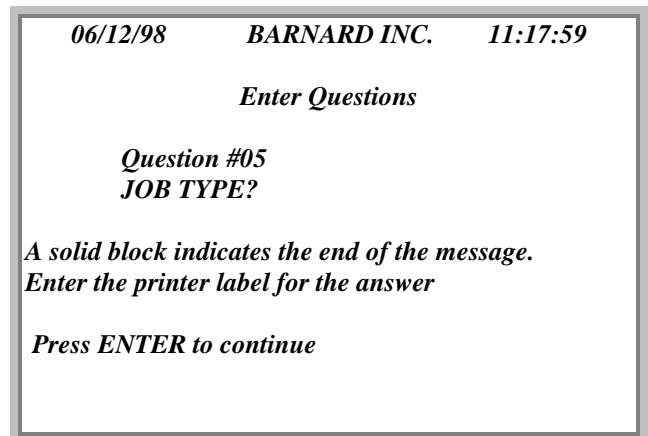

Figure 2-11 Question - Printer Label

Did you notice your screen changed? The line that formerly read, "Enter the question to be asked" now reads "Enter the printer label for the answer". What you type in for the printer label answer will be printed on your audiogram printout if you have entered and selected this question. The first entry you made "JOB TYPE?" is what you will see when you go to the Data Entry Mode to answer your questions. The second entry i.e., "WHAT'S MY JOB? _ _ _ _ _" will be printed as a question on the tape.

All selected questions can be accessed and answered by pressing the data entry key and following the screen instructions. See Section V, Paragraph entitled Data Entry for how to answer questions.

2-6 OPTION 6 - Set Baud Rate

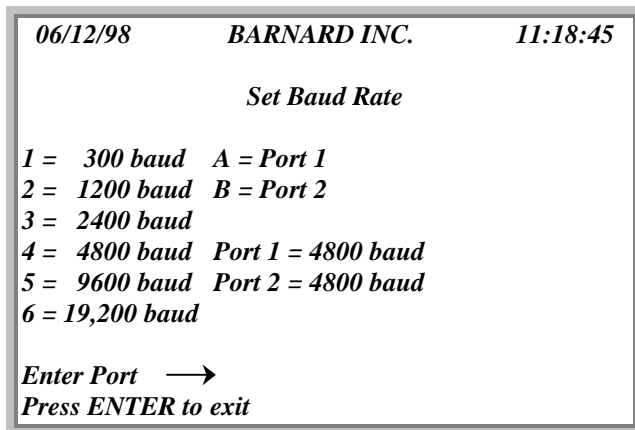

Figure 2-12 Set Baud Rate

Press [0], [6] and [ENTER] to reach the Set Baud Rate menu. The desired baud rate for transfer to a computer is entered here. You can select from 300 - 19,200 baud.

You must first select which serial port (port 1 or port 2) you want to configure. First press either the [A] or [B] key to select one of the two serial ports. If you press [A], you will notice the display change. The phrase, "Enter Baud Rate" is displayed under the "Enter Port", press the number key that applies to the baud rate you want. Repeat the process for selecting your second serial port baud rate. Press [ENTER] to exit.

2-7 OPTION 7 - Select/Delete Frequencies

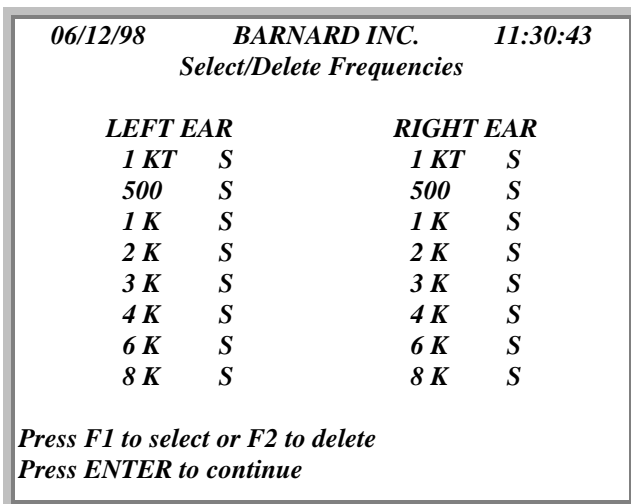

Figure 2-13 Select/Delete Frequencies

Press [0], [7] and [ENTER] to reach the Select/Delete Frequencies menu. You can select or delete any frequency from 500 Hz to 8000 Hz by following the screen prompts. Simply press the [F1] key to select or delete any frequency. You will notice that you can see which ones you're selecting and deleting by looking at the screen in Figure 2-13. The arrow cursor will go to next frequency each time the frequency is either selected or deleted. After selecting or deleting each frequency the screen will automatically return to the set-up menu display.

2-8 OPTION 8 - Select PBI Calculations

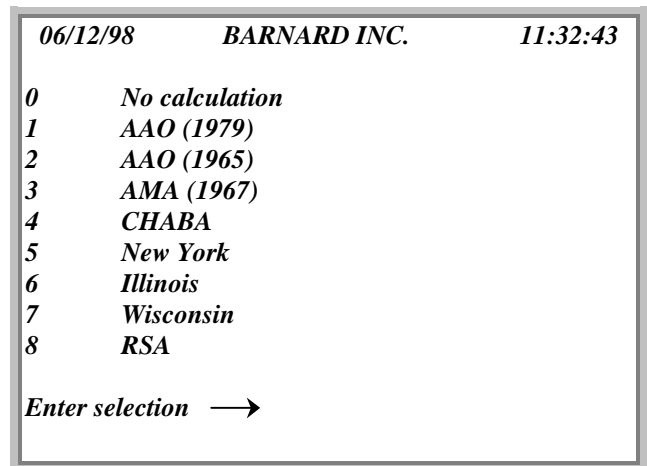

Figure 2-14 Select PBI Calculations

Press [0], [8] and [ENTER] to reach the Select PBI Calculations menu. You can select any of the PBI calculations listed in the menu in Figure 2-14 by pressing the number of the appropriate calculation, and then pressing [ENTER]. If no PBI calculation is desired, then press [0] and [ENTER]. Once a PBI calculation is selected it will automatically be calculated during your test. The results will also be printed on the audiogram tape strip.

2-9 OPTION 9 - Set Beep Tone Level

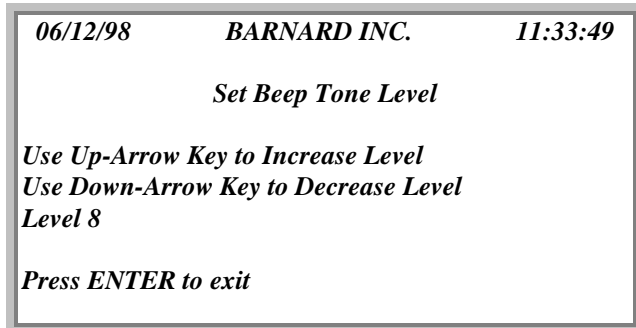

Figure 2-15 Set Beep Tone Level

Press [0], [9] and [ENTER] to reach Set Beep Tone Level menu. By following the display screen directions you can adjust the intensity of the sonalert (that is the beep you hear when you press the keys). The levels go from mute up to approximately 90 dB in ten steps. Just push the key and listen for the intensity level you want. Then press the [ENTER] key when you are done.

At this point, press [F1] to go to page 2 of your set-up option menu.

2-10 OPTION 10 - Select Pulse/Continuous

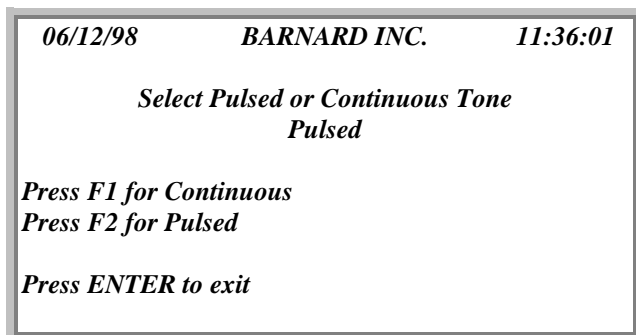

Figure 2-16 Select Pulse/Continuous

Press [1], [0] and [ENTER] to reach Select Pulse/Continuous menu. You can select either a continuous or pulsed tone, by pressing [F2] for pulsed or [F1] for continuous tone. Press [ENTER] to return to the set-up menu display.

2-11 OPTION 11 - Select Beep Response for Keyboard

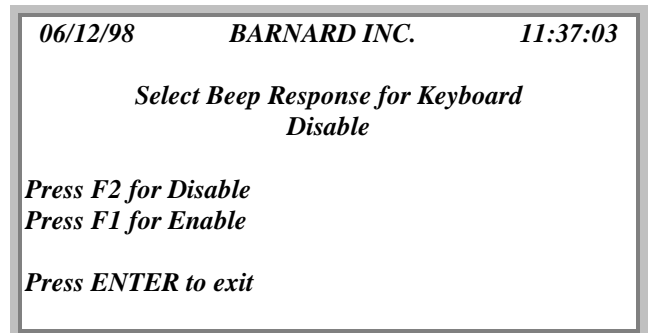

Figure 2-17 Select Beep Response for Keyboard

Press [1], [1] and [ENTER] to reach Select Beep Response for Keyboard menu. Option #11 allows you to select the beep after any key is pressed. You press [F1] to include it or [F2] to remove it. When selected, you can use set-up option number 9 to select the intensity level of the beep.

2-12 OPTION 12 - Select Top Test Level

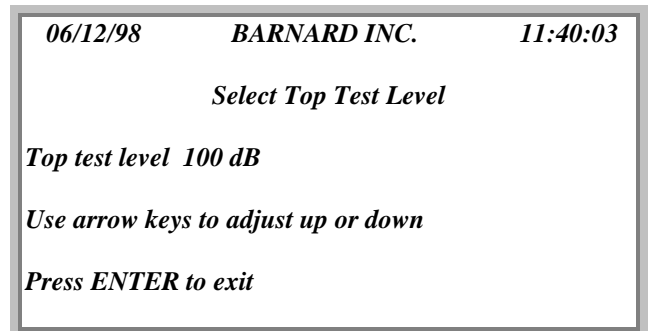

Figure 2-18 Select Top Test Level

One of the unique features of your RA500 allows you to preselect the top, or highest limit of your test. To do this, press [1] and [2] followed by pressing [ENTER]. You then decide what the highest level you want your RA500 to operate at. (Let's say you want the top level to be 95 dB). Press the up or down arrow key until the screen display shows the desired level, then press [ENTER]. The attenuator on your RA500 will stop at 95 dB.

2-13 OPTION 13 - Select Bottom Test Level

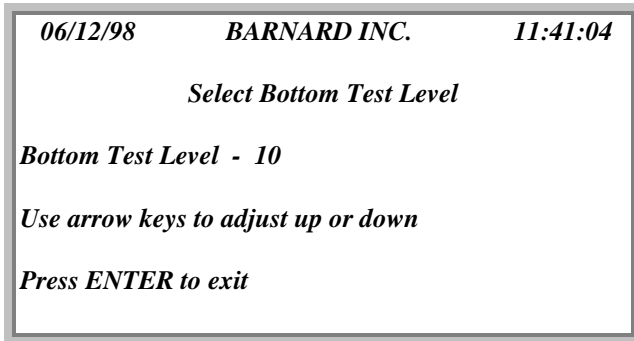

Figure 2-19 Select Bottom Test Level

Press [1], [3] and [ENTER] to reach Select Bottom Test Level menu. As with option # 12, you will use option # 13 to select your lowest test level. If you want your RA500 to test down to -5dB, press the up and down arrow keys until the level displays -5dB. Then press the [ENTER] key to lock in your choice. Your RA500 will now test down to -5dB.

2-14 OPTION 14 - Select Beep at Test Complete

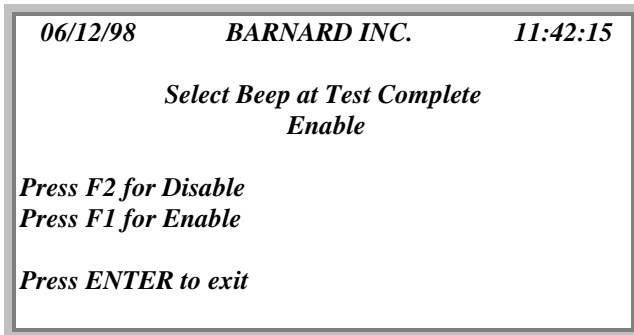

Figure 2-20 Select Beep at Test Complete

Press [1], [4] and [ENTER] to reach Select Beep at Test Complete menu. You may want to have your RA500 produce a "beep" sound when an automatic test is complete. Press the [F1] key to enable it or the [F2] key to disable it. Remember, the intensity level of the "beep" is selected by using option # 9.

2-15 OPTION 15 - Enter Password for Security

The password security system for your RA500 has been designed to give only authorized personnel the ability to perform certain functions. The proper password will allow you to configure your audiometer

and set-up options, edit stored data, and perform calibration routines.

The password security system is a very important part of your RA500. Before using it, you should make sure that you really need it operating as part of your program. If there is no need for security requirements, leave it turned off.

If you do have the need to use this function remember: **MAKE SURE YOU HAVE WRITTEN YOUR PASSWORDS DOWN WHERE THEY CAN BE FOUND IN CASE SOMEONE FORGETS THEM.** Once the passwords are entered in the Password Security System, you will not be able to do the tasks described earlier if the password is unknown. The security system is doing its job - preventing unauthorized access into the unit due to the wrong (or no) password being entered.

Again, the password security feature is not a toy. Decide if you need to use it, then document your passwords where they can be found. Insure that only those people with the "need to know" have them. By following these steps, you'll prevent wasted time in accessing the power of your RA500.

To enter your password, go to the set-up menu and press [1], [5] and [ENTER]. Your screen will look like this:

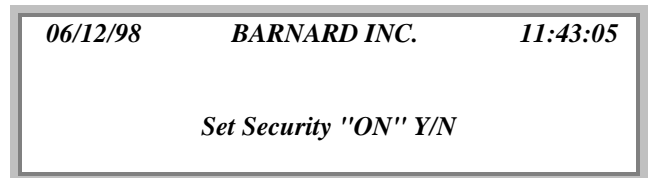

Figure 2-21 Enter Password for Security

If you want to take the security password system out of operation, press the [N] or [NO] key. The display screen will return to the set-up menu. If you press the [Y] or [YES] key, your display screen will look like this:

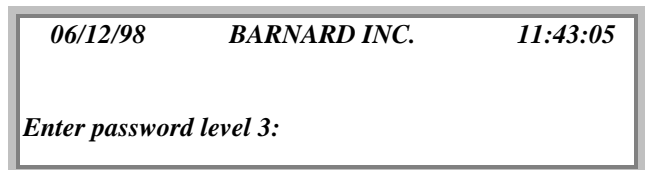

Figure 2-22 Enter Password Level

Enter a password -- either letters, numbers, or some combination. For example, let's use 123456. Press these numbers and you will see them displayed. **You must enter six letters or numbers for each security password level.** Press the [ENTER] key and the display will read as follows:

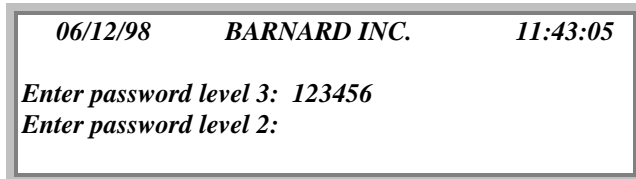

Figure 2-23 Enter Password Level 3

Now enter your password for level 2. Let's use 111111 here. You will see ones displayed on this level. Press [ENTER] and you will see this display:

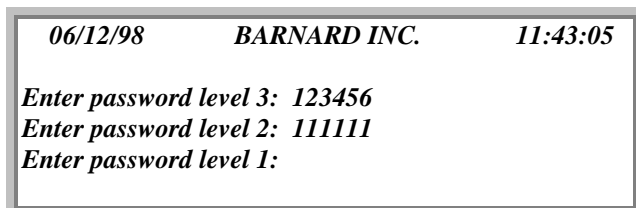

Figure 2-24 Enter Password Level 1

Enter your code for Level 1, let's use ABCDEF. You will see these as you enter the letters. You should now have three different security levels entered. Press [ENTER] and you will return to the main set-up menu window.

The three security levels allow you to do the following:

Password Level 3 -- Password entry, default configuration set-up.

Password Level 2 -- Delete menu, set-up menu and reset questions.

Password Level 1 -- For future use.

Password level codes can be used from the highest number down. For example, an operator with password level 3 can do the functions for levels 3, 2 and 1. You might use level 3 for senior management personnel, and level 2 for supervisors, operators and technicians.

2-16 OPTION 16 - Select Bar Graph Print of Audiogram

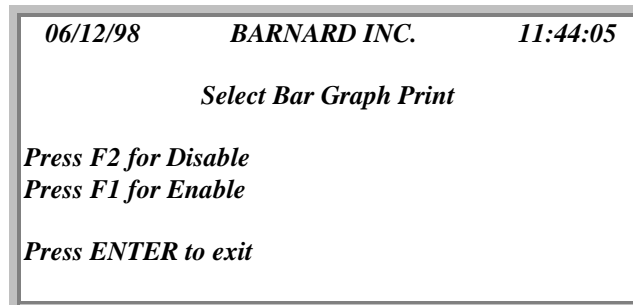

Figure 2-25 Select Bar Graph Print of Audiogram

This option lets you select a graph of the current audiogram to be printed on the audiogram tape immediately after your test results. Press [1] and [6] and [ENTER] to reach this option, then press [F1] to enable this option or [F2] to disable it.

2-17 OPTION 17 - Select Raw Data Dump to Print



Figure 2-26 Select Raw Data Dump to Print

Select raw data dump print allows the subject's actual responses at each frequency and each hearing threshold level to be printed on the audiogram tape. When selected, it will appear after the current audiogram (or after the bar graph of the audiogram, if selected).

To select this option, press [1] and [7] and [ENTER]. Then follow the screen instructions and press [F1] to enable or [F2] to disable.

2-18 OPTION 18 - Set Default System Configuration

NOTE: No data will show on screen when Option #18 is pressed. The screen will return to page one of the Set-up menu.

There may be times when you want to set your RA500 back to the way you received it from our factory. Set-up option number eighteen allows you to do this. Press [1] and [8] and [ENTER] to select this option. **When you have done this, the RA500 automatically goes to the default parameters - there is no display or warning to tell you that it has happened. To review your factory default settings see Section VIII.**

2-19 OPTION 19 - Select Audio Print at Test Complete

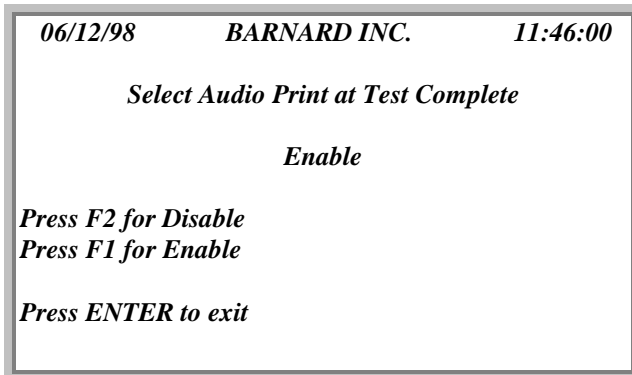

Figure 2-27 Select Audio Print at Test Complete

Press [1], [9] and [ENTER] to reach Select Audio Print at Test Complete menu. You can select the audiogram to print at the completion of your test by pressing [F1]. To prohibit the audiogram from printing when your test is done, press [F2].

2-20 OPTION 20 - Set Talk-Over Output Level

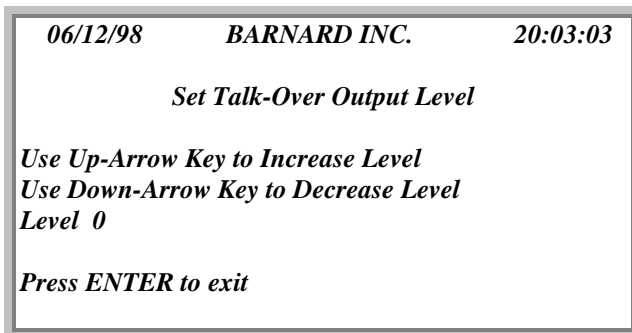

Figure 2-28 Set Talk-Over Output Level

Press [2], [0] and [ENTER] to reach Set Talk-Over Output Level menu. This option allows you to adjust the output level of the internal talk-over microphone. By pressing the up-arrow key on the numeric keypad, the output level of the microphone increases, pressing the down arrow key will decrease the output level. There are ten output levels which are labeled 0 to -9 with -9 being the lowest level.

2-21 OPTION 21 - Select Test the Right Ear First

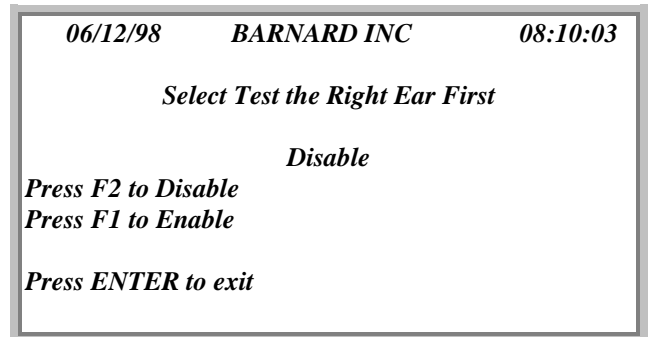

Figure 2-29 Select Test the Right Ear First

Press [2], [1] and [ENTER] to reach Select Test the Right Ear First menu. Option 21 will allow you to select the right ear as being the first one tested each time a test is given. This option will remain active until you disable it. In the disable position, the left ear is always tested first.

2-22 OPTION 22 - Enter Communications Password

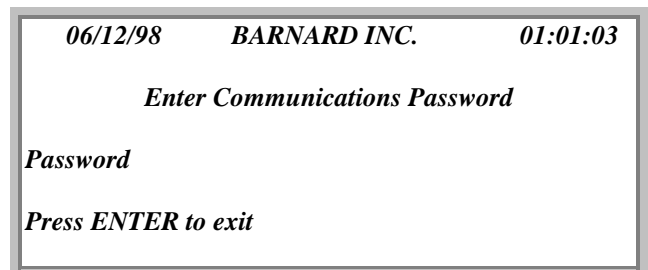

Figure 2-30 Enter Communications Password

Press [2], [2] and [ENTER] to reach Enter Communications Password menu. Option 22 allows you to enter your password to open up the telecommunication power of your RA500. If the correct password is not entered, the main set-up menu appears on your screen. If entered correctly, then you are permitted into the telecommunications mode.

2-23 OPTION 23 - Enter Communication User ID

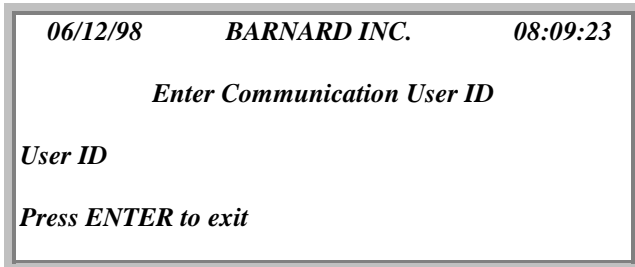

Figure 2-31 Enter Communication User ID

Press [2], [3] and [ENTER] to reach Enter Communication User ID menu. Option # 23 allows you to enter your own identification, either text or numeric in your RA500, for use in the telecommunications mode.

NOTE: Option 22 and Option 23 can be used only with specially customized versions of the RA500. They are written for telecommunications only, and have no application for RA500 to PC transfer.

2-24 OPTION 24 - Enter Communication Phone Number

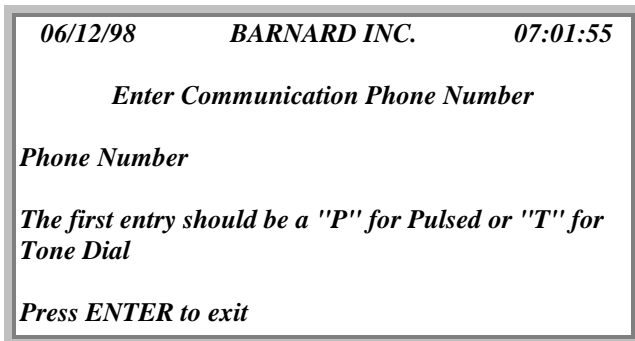

Figure 2-32 Enter Communication Phone Number

With set-up option # 24, you can enter the phone number you want your RA500 to dial. This will allow your RA500 to communicate by telephone modem to another computer. From the set-up menu, press [2], [4] and [ENTER]. When you see the screen shown in Figure 2-32, type in the area code and phone number you desire. Once you have entered in the phone number, press [ENTER] to exit from the menu.

NOTE: Special software is required to do any telecommunications transfer. Contact Tremetrics for further information.

2-25 OPTION 25 - Enter Auto-Transmit Time



Figure 2-33 Enter Auto-Transmit Time

In option # 25, you can program in the time you want your RA500 to automatically dial up the receiving party and transmit your data. The first two digits are the hour, the next two are minutes and the next two are seconds. The time used is the standard 24 hour format. The colons are displayed automatically after the hour and minute. To begin, press [2], [5] and [ENTER], then use your numeric keys to type in the time in the hour:minute:second format. Again remember, you must use 24-hour time for your entry. The following is a reference to use to convert standard time to 24-hour time.

STANDARD TIME	24-HOUR TIME
12 am	0000
1 am	0100
2 am	0200
3 am	0300
4 am	0400
5 am	0500
6 am	0600
7 am	0700
8 am	0800
9 am	0900
10 am	1000
11 am	1100
12 pm	1200
1 pm	1300
2 pm	1400
3 pm	1500
4 pm	1600

(continued on next page)

5 pm	1700
6 pm	1800
7 pm	1900
8 pm	2000
9 pm	2100
10 pm	2200
11 pm	2300

NOTE: If transmission is desired at midnight, set the auto transmit time to either 23:59 or 00:01.

2-26 OPTION 26 - Communication Monitor Mode

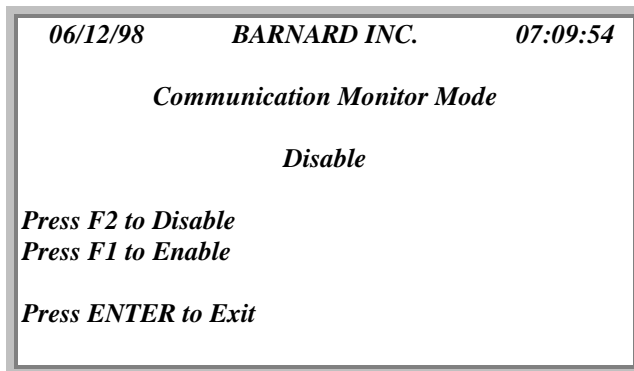

Figure 2-34 Communication Monitor Mode

Press [2], [6] and [ENTER] to reach Communication Monitor Mode menu. With Option 26, you must first enter your password (see pages 2-6 and 2-7 for Password Discussion - Option Number 15). You will not be able to activate this option without entering your password. Once you have successfully entered your password you will see the screen as displayed in **Figure 2-34**.

This option allows you to monitor the communication stream going on between the RA500 and a personal computer. By viewing it, you will have visual indication that data is being transferred from the unit's RS232C port to the personal computer. To enable it, press [F1]. The word disable should change to "Enable". To disable it, just press [F2].

2-27 OPTION 27 - Select STS/Categorization

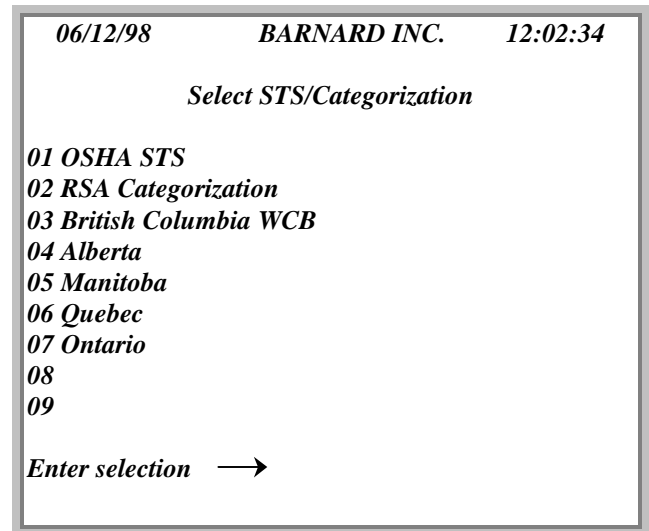

Figure 2-35 Select STS/Categorization

Press [2], [7] and [ENTER] to reach Select STS/Categorization menu. With Option 26, you can select Threshold Shift Classifications for U.S. OSHA, Canadian Provinces, and European Categorization. The formulas are stored in the RA500 so that when you select the one you wish, your audiograms will be calculated with the appropriate calculation. To select the one of your choice, go to your set up menu and press [0], [the number of your choice] (see **Figure 2-35**), and [ENTER]. Your RA500 is now set to calculate for your choice until it's changed.

You will note that there are Canadian standards and categorization which can be selected. On the audiogram tape printouts, certain category levels will be printed. Your RA500 has been programmed to automatically analyze the test and place it in a particular category. The analysis is based upon standards programmed and selected for each requirement in Setup No. 27. The following are the designations you will see on the test printout:

NSD	=	Insufficient Data
N	=	Normal
A	=	Abnormal
EW	=	Early Warning
NC	=	Normal Change
AC	=	Abnormal Change
EWC	=	Early Warning Change

2-28 **OPTION 28 - Select Quick Screen Mode**

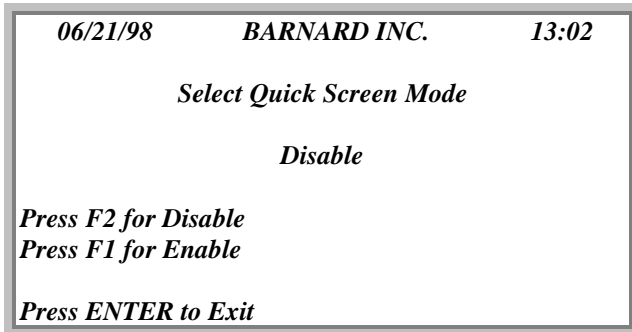
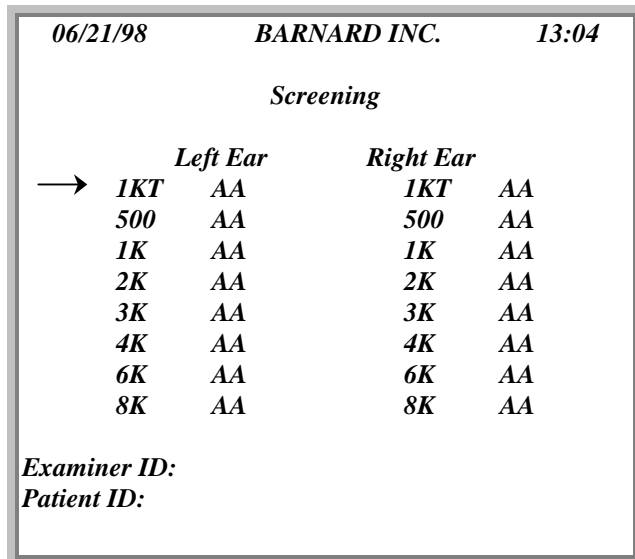

Figure 2-36 Select Quick Screen Option

Option 28 allows you to operate your RA500 in a quick screening test mode. To enable this feature, press the set-up key and type [2], [8] and [ENTER]. This will display the screen you see above in **Figure 2-36**. To enable this feature, press [F1] to enable it and press [F2] to disable.

When Quick Screen is enabled, you will see the main test screen displayed as follows:



Notice the word SCREENING which is displayed at the top of the display. It appears as soon as the RUN TEST key is pressed, indicating that the test has begun. The first frequency tested is the left ear at 1KHz (Notice the arrow pointing to the 1KT frequency).

The test starts at 30dB with the words "Testing" (indicating the test is in progress) and "Tone" (displayed when a tone is presented to the subject)

being presented on the screen. As each tone is presented, the subject should press the handswitch as soon as the tone is heard.

Quick Screen mode differs from the modified Hughson-Westlake test in it only takes one subject response at each frequency to register a response level at each frequency. A subject can be screened much quicker than in the regular modified Hughson-Westlake mode.

NOTE: The quick screen mode is not a substitute for testing under OSHA regulation 1910. Its sole purpose is to provide an alternative method to quickly (screen) test a subject's hearing without establishing a threshold in the conventional modified Hughson-Westlake method. You will note that on your audiogram printout the words "QUICK SCREEN" are printed where the name of your company usually appears. In addition, a message also appears on the printout stating that this test does not comply with OSHA standards.

BARNARD INC.

DATE: 01/11/99
 TIME: 11:13:43

PATIENT: 88974

QUICK SCREEN

FREQ		L/DB	R/DB
1000	HZ	35	30
500	HZ	30	30
V1000	HZ	30	30
2000	HZ	30	30
3000	HZ	30	30
4000	HZ	30	30
6000	HZ	30	30
8000	HZ	30	30
AVG 2,3,4		030.0	030.0

TEST ID: 3431116240090009

ELAPSED TIME = 00:29

TREMETRICS INC. RA500
 SERIAL NUMBER... 00890009
 SOFTWARE REV. 2.21-990105
 CALIBRATION: 08/19/98
 CAL.ANSI S3.6 1989

**THIS QUICK SCREEN TEST DOES
 NOT MEET OSHA STDS**

PATIENT: 88974
 X_____

EXAMINER: 2213
 X_____

QUESTION ANSWERS

LAST NAME:
 FIRST NAME:
 DOB:
 SEX:

Figure 2-36A Quick Screen Printout

2-29 OPTION 29 - Set Maximum Failed Frequencies

06/21/98 BARNARD INC. 13:06:23

Set Max Failed Frequencies

Enter Number of Failed Frequencies

Press ENTER to Exit

Figure 2-37 Set Maximum Failed Frequencies

Option 29 permits you to set how many failed frequencies will be registered before the test stops.

Your RA500 will stop testing on the first 1000 Hz test if it can not establish a threshold for your subject. At other frequencies, the test will keep going and the frequencies will be retested after going through the first test cycle (1KHz left ear to 8KHz right ear).

Let's say you select 5 for the number of failed frequencies before the test will stop. As always, you can be anywhere in the set-up menu to select a set-up option. Press the [two] and [nine] key, and then press the [ENTER] key. You will see the screen display in *Figure 2-37*.

Now to select five failed frequencies as your maximum, press the [5] key. You will see the number "5" displayed where the cursor previously appeared. Now press [ENTER] to lock in your selection.

With five failed frequencies as your maximum, your RA500 will stop testing if it registers five failed frequencies for both ears (This means that, excluding left ear at 1KHz, if your subject could not establish a threshold for five frequencies, that's your maximum number before the test completely stops).

You, the operator, now have the flexibility to set your audiometer to stop when any number of "failed" frequencies appear.

2-30 OPTION 30 - Select Auto Tag in Store Test



Figure 2-38 Select Auto Tag on Store Test

Option 30 deals with tagging, or marking an audiogram for transfer between your RA500 and a personal computer. Your computer must have a data base hearing conservation management program, such as Tremetrics FOSHM to receive the data.

You will want to select the Auto Tag function when you want to have any test you have stored tagged for eventual transfer to your personal computer. To set this function in your RA500, press the [3] and [0] keys and then the [ENTER] key. You will see the screen displayed in **Figure 2-38**. Press the [F1] key to set the auto tag function.

To verify that your audiograms have been tagged, go to the special menu and select Special 14. You will see the "T" in the far right hand column which notes that the audiogram selected has been tagged. (See Special chapter, Special 8 and 14.)

If you wish to disable this feature, go back to the set-up menu and select set-up option number 30. Press the [F2] key to disable it. From that point on, all stored audiograms will not be marked or tagged for transfer to a personal computer. Remember, you only see this option if your using a computer and a hearing conservation software package. It is not necessary to use option 30 if you are not using a computer.

NOTE: Upon completion of the valid transfer between RA500 and the PC, all tagged audiograms will be untagged. This allows only tests stored since the last time you transferred to be sent to the PC.

2-31 OPTION 31 - Select Tagged Transfer Data



Figure 2-39 Select Tagged Data Transfer

By enabling option number 31, you can tag or mark your audiograms for transfer to a personal computer with an appropriate hearing conservation program.

To use this option, make sure you are in the set-up mode, press the [3] and [1] keys and then press [ENTER]. You will see the display in **Figure 2-39**. Press the [F1] key to enable this option. When you have done this, any audiograms that have been tagged for transfer will be transferred to the computer. To disable the function, you must press the [F2] key.

2-32 OPTION 32 - Enable/Disable Adaptive Mode

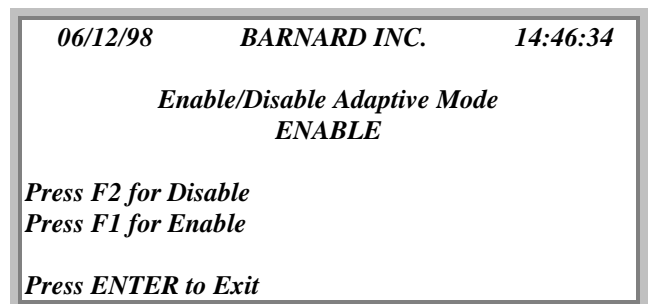

Figure 2-40 Enable/Disable Adaptive Mode

Your RA500 contains a unique feature called the Adaptive Mode. To select this feature, make sure you are in the set-up mode and press the [3] and [2] keys, then press [ENTER]. Your screen will appear as in **Figure 2-40**. Press the [F1] key to enable this function, and to disable it, press the [F2] key.

The Adaptive Mode lengthens the subject response window (that's the time from the end of the presented tone to the end of the time allowed for the subject to respond). This is done in order to allow the subject the opportunity to register a valid response without having to stop and test in the manual mode.

Enabling the Adaptive Mode will permit it to be used only if the subject's handswitch responses dictate. It does not automatically put the Adaptive Mode in as part of the test routine.

The Adaptive Mode will automatically be engaged by analyzing the subject responses to the tones presented by the RA500. When Adaptive Mode is in control, the message "In Adaptive Mode" is displayed at the bottom of the test screen while the test is being conducted.

Disabling the Adaptive Mode prevents the Adaptive Mode from being initiated from the audiometer.

2-33 *Option 33 - Select Flow Gemini Comm Mode*

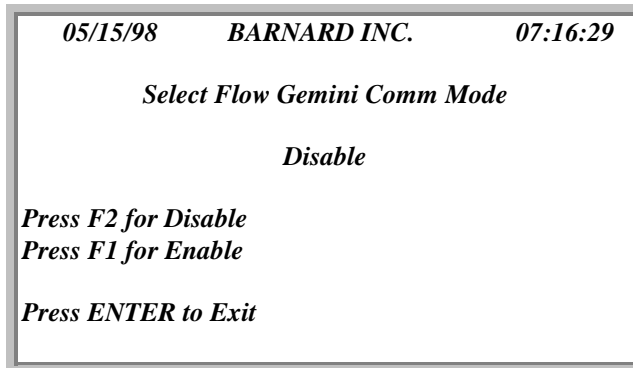

By enabling setup option number 33, you have the ability to format the audiometric data stream in a format acceptable to the Flow Gemini mainframe occupational health data base.

NOTE: If you are not using the Flow Gemini program, setup option number 33 must be disabled.

This concludes the overview of the set-up menu. As you can see, you have the ability to totally customize your RA500 without expensive and time consuming factory programming. Once you have set up your various options, you should rarely have to return to the set-up menu to change them. And remember, all your instructions are battery backed so you only have to set up your options once.

***Explanation of Custom Specials in Your
RA500
Section III***

In addition to the set-up options (which are generally only used once when first initializing the audiometer) there are several special program functions that you will generally use more than the set-up options. They are:

- 01 Calibration Mode
- 02 Clear and Reset Entered Questions
- 03 Printer Test
- 04 Serial Port Test
- 05 Delete Data From Storage Menu
- 06 Accelerated Listening Check
- 07 Change Test Type
- 08 Recall Test From Storage
- 09 Storage Memory Remaining
- 10 EPROM Error Test
- 11 RAM Error Test
- 12 Keyboard Test
- 13 Enter/Store Multiple Baselines
- 14 Tag Records for Transfer

As we did with the set-up options, let's review each of the "Special" options one by one.

3-1 SPECIAL 01 - Calibration Mode

EEPROMs are used to store calibration data for your unit, guaranteeing accurate and permanent calibration. Calibration will not be discussed in detail here. Your audiometer must be recalibrated once each year and once every two years for an exhaustive calibration. To calibrate your RA500, you must know the pass code to gain access to the routine. To arrange for calibration, contact your nearest authorized TREMETRICS dealer or our factory in Austin, Texas.

3-2 SPECIAL 02 - Clear and Reset Entered Questions

Special 02 allows you to clear your questions previously entered in the RA500. To access this function, first you must press the [SPECIAL] key and then press [0] and [2]. Follow your screen instructions to clear your questions. **Remember though, when you press the [ENTER] key, all of your questions you have previously entered will be deleted and you will have to enter them again, by using the Option #5 - Enter Questions.**

NOTE: The first four questions -- Last name, First name, Middle initial, Date of birth and Sex are always entered in memory. They cannot be removed but they can be deleted from the test routine if desired.

3-3 SPECIAL 03 - Printer Test

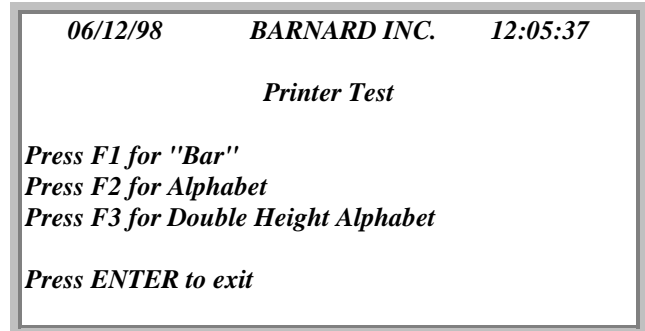

Figure 3-1 Printer Test

From time to time, you may want to test the quality of your printer.

The RA500 uses a fast and virtually noiseless printer with high quality graphics. Its quality should be consistent for hundreds of printed tests. It requires no maintenance by you, the user.

To select this special, press the [SPECIAL] key, then [0] and [3]. Again, follow the instructions on the screen. As you will see you will be instructed to press [F1], [F2] or [F3], depending upon which characters you wish to check. F1 is for the bar test pattern on the bar graph, F2 prints the larger character's test and F3 prints the smaller ones. Press the [ENTER] key to return to the main test screen.

3-4 SPECIAL 04 - Serial Port Test

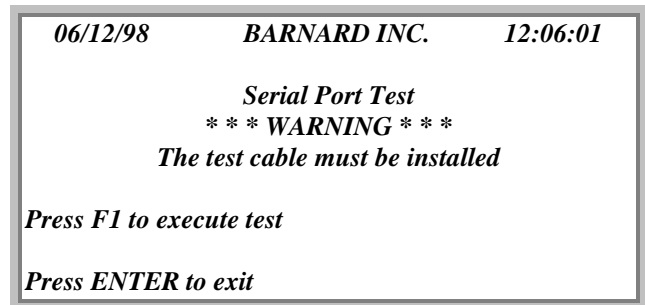

Figure 3-2 Serial Port Test

By pressing the [SPECIAL] key and [0], [4] you can access the Serial Port Test routine. As you will note by the screen display, the test cable (a 25-pin serial port connector) must be connected from one port to

```

06/12/98  BARNARD INC.  12:06:01

Serial Port Test
***WARNING***
Test cable installed

Serial Port 1: Test passed
Serial Port 2: Test passed

Press F1 to execute test
Press ENTER to exit
    
```

```

06/12/98  BARNARD INC.  06:41:14

Delete Menu

01 Delete all records stored
02 Delete all Non-BL records stored
03 Delete all bl records stored
04 Delete for patient ID #'s
05 Select record to delete
06
07
08
09

Enter selection  →
    
```

- stored in memory.
- 02 **Delete all non-baseline records stored** - pressing [0] and [2] will erase all audiogram records not marked as baseline audiograms.

- 03 **Delete all baseline records stored** - pressing [0] and [3] and [ENTER] will erase all baseline audiograms you have stored.
- 04 **Delete for patient ID numbers** - Pressing the [0], [4] keys will delete all stored audiograms under any one particular patient identification number.
- 05 **Select record to delete** - By pressing the [0], [5] keys, you can delete a single stored audiogram for any one particular patient. You can delete individual audiograms in your RA500's internal memory storage by selecting this menu item. Pressing the [0] and [5] keys will display the screen below.

+++ The Delete menu items 01, 02 and 03 enables the operator to delete records within a specified date range, if desired.

```

06/12/98  BARNARD INC.  06:41:28

PATIENT ID  TT  DATE  TIME
123456789  0  03/28/98  09:05
526762267  1  02/03/66  11:42 T
2           0  03/30/98  16:38 T
526762267  0  03/30/98  17:11
44          0  04/03/98  15:46 T
554         0  04/03/98  15:46
771         1  04/03/98  15:47 T
490607645  1  04/03/98  15:48
490607645  0  04/03/98  15:50
3333       1  08/08/79  13:50

2/8=UP/DOWN&F1/F2=PAGE-DOWN/ PAGE-UP
PRESS F6 TO DELETE OR ESC TO EXIT
    
```

Figure 3-5 Individual Audiogram Delete Menu

To delete a particular audiogram, first scroll down the "page" following the directions on the screen. As you scroll up and down, you will see the arrow move up and down by each individual patient ID number. If you have more than 11 audiograms stored, use the F1 and F2 keys to page up and down in the menu. This will help you reach the desired patient much faster.

The Delete menu item 05 has the following keys used to move around the screen for the RA500 Plus:

WAYS TO MOVE AROUND	KEYS TO USE
Scroll up line by line	2 or ↑
Scroll down line by line	8 or ↓

	←
Page down	6 or →
Sort by date or ID number	F3
Search by ID number	F4

When you have reached the one you want, press the [F6] key. You will see the following screen:



Figure 3-6 Verification Message

Press the [YES] key and the following printout will appear.



Figure 3-7 Deleted Audiogram

The printout is your verification that the audiogram has been deleted. If you press the [No] key, you will be taken back to the display in **Figure 3-5** where you can delete other audiograms or return to the main test screen.

To leave the special menu and return to the main test screen, press [ENTER].

3-6 SPECIAL 06 - Accelerated Listening Check



Figure 3-8 Accelerated Listening Check

By selecting [SPECIAL] [0], [6], you can listen to any frequency at any threshold level you choose. Accelerated listening can be done from either the handswitch or the keyboard. If the handswitch is used, each frequency is generated at a constant level, starting with the left ear and changing to the right. After each frequency has been selected in each ear, the levels are varied while the frequency remains constant.

Accelerated listening check is a fast and efficient way for you to check the purity of your RA500's tones on a periodic basis.

3-7 SPECIAL 07 - Change Test Type

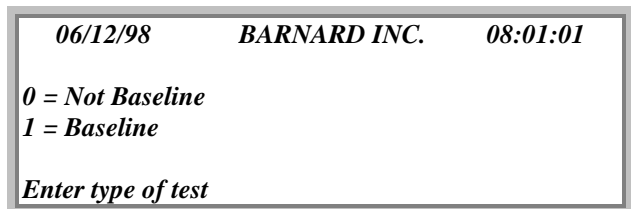

Figure 3-9 Change Test Type

[SPECIAL], [0] [7] permits you to change the test type. You can change your test after you completed it but just before it's been stored. When you have pressed the [0] or [1] keys, the display will change back to the main test display screen. You can then store your test.

<i>06/12/98</i>		<i>BARNARD INC</i>		<i>06:41:28</i>
<i>PATIENT ID</i>	<i>TT</i>	<i>DATE</i>	<i>TIME</i>	
<i>123456789</i>	<i>0</i>	<i>03/28/98</i>	<i>09:05</i>	
<i>526762267</i>	<i>1</i>	<i>02/03/66</i>	<i>11:42 T</i>	
<i>2</i>	<i>0</i>	<i>03/30/98</i>	<i>16:38 T</i>	
<i>526762267</i>	<i>0</i>	<i>03/30/98</i>	<i>17:11</i>	
<i>44</i>	<i>0</i>	<i>04/03/98</i>	<i>15:46 T</i>	
<i>554</i>	<i>0</i>	<i>04/03/98</i>	<i>15:46</i>	
<i>771</i>	<i>3</i>	<i>04/03/98</i>	<i>15:47 T</i>	
<i>490607645</i>	<i>1</i>	<i>04/03/98</i>	<i>15:48</i>	
<i>2/8=UP/DOWN&F1/F2=PAGE-DOWN/ PAGE-UP</i>				
<i>PRESS ENTER TO RECALL OR ESC TO EXIT</i>				

Scroll up line by line	2 or ↑
Scroll down line by line	8 or ↓
Page up	4 or ←
Page down	6 or →
Sort by date or ID number	F3
Search by ID number	F4

To display the screen, just press the [ENTER] key after you have found the audiogram you want to recall. If you want a printed copy, press the [PRINT TEST] key. If a baseline is stored along with a patient's current test, the baseline will automatically be printed with the recalled test, and the STS (Standard Threshold Shift) will be displayed on the tape strip.

NOTE: When you have recalled the audiogram you cannot revise it and reenter it back into storage. The purpose of this Special is not to revise the recalled audiogram - only to recall, review and print a copy.

3-9 SPECIAL 09 - Display Storage Memory Remaining

<i>06/12/98</i>		<i>BARNARD INC.</i>		<i>12:14:58</i>
<i>Display Storage Memory Remaining</i>				
<i>Percent of Memory Remaining = 96%</i>				
<i>Press ENTER to exit</i>				

Figure 3-11 Percent of Memory Remaining

Special 09 will display the amount of storage capacity left in your RA500's memory. From the special menu, press [SPECIAL] [0], [9] and [ENTER]. Your display will show the percent of memory remaining for audiogram storage. After an audiogram is stored, the percent of memory remaining will decrease in number. How much will depend upon several factors. The number of questions and the length of their answers stored with the test is the biggest factor. After you delete an audiogram, you will notice that this number will increase.

The percent of memory remaining indicator is a method for monitoring how much storage space the

06/12/98 BARNARD INC. 18:15:00

Keyboard Test

<i>A</i>	<i>B</i>	<i>C</i>	<i>D</i>	<i>E</i>	<i>F</i>	<i>G</i>	<i>H</i>	<i>1</i>	<i>2</i>	<i>3</i>	<i>c</i>	
<i>I</i>	<i>J</i>	<i>K</i>	<i>L</i>	<i>M</i>	<i>N</i>	<i>O</i>	<i>P</i>	<i>Q</i>	<i>4</i>	<i>5</i>	<i>6</i>	<i>0</i>
<i>R</i>	<i>S</i>	<i>T</i>	<i>U</i>	<i>V</i>	<i>W</i>	<i>X</i>	<i>Y</i>	<i>Z</i>	<i>7</i>	<i>8</i>	<i>9</i>	<i>e</i>

EPROM Error Test Passed

Press ENTER to exit

06/12/98 BARNARD INC. 12:32:27

Enter/Store Mult Baselines

Enter Patient ID

06/12/98 BARNARD INC. 18:14:43

RAM Error Test Passed

Press ENTER to exit

06/12/98 BARNARD INC. 13:29

Enter Baseline Audiogram

<i>Left Ear</i>	<i>Right Ear</i>
500 AA	500 AA
1K AA	1K AA
2K AA	2K AA
3K AA	3K AA
4K AA	4K AA
6K AA	6K AA
8K AA	8K AA

Enter Date →

06/12/98 BARNARD INC. 13:29

Enter Baseline Audiogram

<i>Left Ear</i>	<i>Right Ear</i>
500 15	500 AA
1K AA	1K AA
2K AA	2K AA
3K AA	3K AA
4K AA	4K AA
6K AA	6K AA
8K AA	8K AA

Enter Date →

06/12/98 BARNARD INC. 13:29

Enter Baseline Audiogram

<i>Left Ear</i>	<i>Right Ear</i>
500 15	500 AA
1K AA	1K AA
2K AA	2K AA
3K AA	3K AA
4K AA	4K AA
6K AA	6K AA
8K AA	8K AA

Enter Date → 03/03/98

Information Correct Y/N?

Enter/Store Mult Baselines

Press Store Test Key to Store Baseline
Press F1 to Continue or F2 to Exit

06/12/98 BARNARD INC. 13:37:35

Enter/Store Mult Baseline

Press Store Test Key to Store Baseline
Press F1 to Continue or F2 to Exit

**** Test Stored ****

04/05/98 BARNARD INC. 06:41:28

<i>PATIENT ID</i>	<i>TT</i>	<i>DATE</i>	<i>TIME</i>
<i>123456789</i>	<i>0</i>	<i>03/28/98</i>	<i>09:05</i>
<i>526762267</i>	<i>1</i>	<i>02/03/66</i>	<i>11:42 T</i>
<i>2</i>	<i>0</i>	<i>03/30/98</i>	<i>16:38</i>
<i>526762267</i>	<i>0</i>	<i>03/30/98</i>	<i>17:11</i>
<i>44</i>	<i>0</i>	<i>04/03/98</i>	<i>15:46 T</i>
<i>554</i>	<i>0</i>	<i>04/03/98</i>	<i>15:46 T</i>
<i>771</i>	<i>1</i>	<i>04/03/98</i>	<i>15:47 T</i>
<i>498607645</i>	<i>1</i>	<i>04/03/98</i>	<i>15:48 T</i>
<i>490607645</i>	<i>0</i>	<i>04/03/98</i>	<i>15:50 T</i>
<i>99</i>	<i>1</i>	<i>03/03/69</i>	<i>13:34</i>

2/8=UP/DOWN&F1/F2=PAGE-DOWN/ PAGE-UP
T=TAG & U=UNTAG PRESS ESC TO EXIT

What Are the Functions of the Keys on My RA500 Keyboard ... and What Do They Do
Section IV

We have discussed the various ways you can customize your RA500 for your specific requirements. You probably have a feel for the layout of the keys already. Before we review running an audiometric test, you should have a good understanding of the keys on your keyboard. To do this, we will "group" the keys in our discussion. This should make it easier for you to follow, and show you the logic in the key placement.

The keys on your RA500 are shown in a diagram on the page 4-3, **Figure 4-1**.

4-1 Group 1 - Supplemental Keys

Let us take a look at Group 1 first. These are called "Supplemental" keys.

The keys in Group 1 are as follows:

Shift	Set Up	Examiner Id
Display Adjust	Transmit	Data Entry
Special	Paper Feed	Store Test

SHIFT

You will use the [SHIFT] key when you want to access characters from Group 5, (those are the question mark, comma, period, colon, slash bar). Shift also allows you to move the cursor to the right (by pressing [SHIFT] and holding it down while pressing the right arrow key) or to the left, (by pressing [SHIFT] and holding it down while pressing the left arrow key) and not overwrite or erase your existing display.

SET UP

The [SET-UP] key takes you to the set up mode. As discussed in Section II, the set-up mode allows you to customize your RA500 with your own unique operation functions. Once you are in the set-up field, remember to push [ENTER] after you have made your numerical selection in the set-up menu. You must press a [0] and the number for the option number 1 through 9.

EXAMINER ID

By pressing the [EXAMINER ID] key, you are able to enter the test examiner's ID, either with letters and numbers. Remember, once your examiner ID has been entered, it will be stored in memory until you

change it. Just follow the screen instructions to get out of this field.

DISPLAY ADJUST

By pressing [DISPLAY ADJUST], you can adjust the intensity of the screen display. There are 50 gradations of intensity varying from 0 (totally a blank screen) to 50 (sharpest intensity). The screen display will be stored in internal memory until you change it. Display adjust will always be at position #25 when you press this key.

TRANSMIT

The [TRANSMIT] key is used to transfer audiograms via telephone modem from your RA500 to personal computer or mainframe.

When you have pressed the [TRANSMIT] key you will see the following screen:

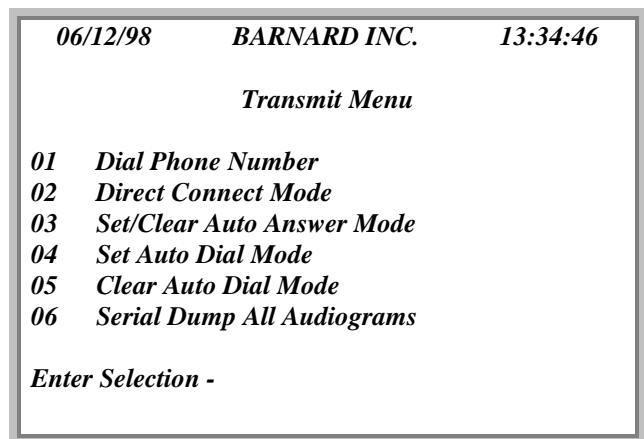
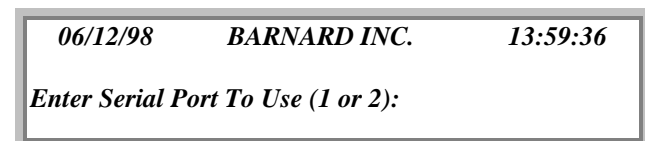

Figure 4-2 Transmit Menu Screen

There are six selections you can make in the Transmit menu. Let's take each one separately.



4-3 Screen Display for Dial Phone Number (01)

When you press the [0], [1] keys, you will see the above screen on the display. You press [1] or [2] depending upon which port your modem is connected. After you have pressed the port number, the phone number will be dialed automatically.

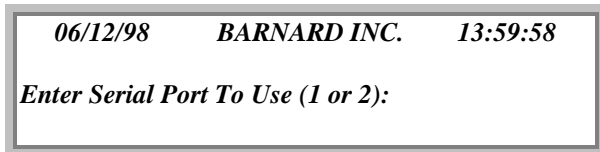

Figure 4-4 Screen Display for Direct Connect Mode

When you press the [0] and [2] key, you will see the display in *Figure 4-4*. Again, you are asked to designate to which serial port you're connected. After you have entered the appropriate number, your data is automatically transferred to the computer into your data management software program.

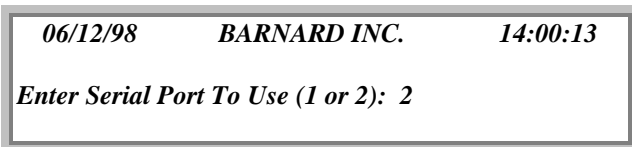

Figure 4-5 Screen Display for Set/Clear Auto Answer Mode

Transmit menu Option # 03 permits your RA500 to designate how many rings of your telephone it will allow before it will answer a download call. As you can see from the screen, you first designate which serial port you're using. Then enter the number of rings your telephone will receive before it answers a download call.

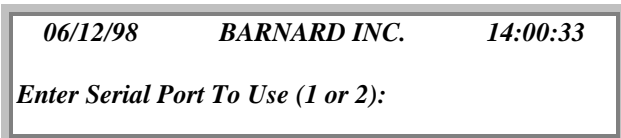

Figure 4-6 Screen Display of Set Auto Dial Mode

Pressing keys [0] and [4] will set the auto-dial mode. This will allow your RA500 to automatically dial the telephone number. You first select the appropriate serial port by pressing [1] or [2]. After doing this, your RA500 will automatically dial the telephone number you entered in Option 24 (see page 2-10).



Figure 4-7 Screen Display of Clear Auto-Dial Mode

When you press the [0] and [5] keys you will have cleared or disabled the auto-dial function. If you want to go back later to reset your auto-dial function, press [0] and [4] to reestablish it.

NOTE: Computer communications, telephone modem communication and combinations of the two can be very complex. It is strongly recommended you contact your authorized TREMETRICS representative or TREMETRICS Customer Service before setting up your program, especially where modem communications and communicating with mainframe computers are involved.

DATA ENTRY

When you press [DATA ENTRY], you can begin entering the answers to your customized questions. This can be done before, during or after the audiometric test. Follow the screen instructions once in the data entry screen. Use both your alpha (letter) or numeric keys as required.

SPECIAL

By pressing the [SPECIAL] key, you are able to access the "Special" functions as listed in *Section III -- Explanation of Custom Specials For Your RA500*. Follow the display screen to exit from this menu.

PAPER FEED

When you push the [PAPER FEED] key, your printer paper is advanced. It will continue to advance until you release the key.

Transmit menu Option 06 Serial Dump All Audiograms is a way for the RA500 to transfer all saved audiograms out of the selected serial port. The RA500 starts with the first saved audiogram and continues until the last audiogram in memory has been sent. There is no handshaking.

STORE TEST

Pressing the [STORE TEST] key allows your audiogram to be stored in the internal storage memory of your RA500. After your audiogram is complete, push the [STORE TEST] key to save it. You must do this before you begin your next audiogram. If you do not store your test and you begin to do your next patient by pressing the [NEW TEST] key, the following display will appear on your screen:

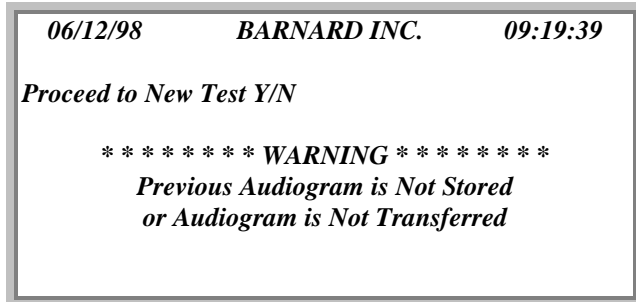

Figure 4-8 Warning Message

See the warning message at the bottom? This lets you know that you have an audiogram that has not been stored in the internal memory storage. If you want to store it, press the [STORE TEST] key. You will be taken back to the main test display screen. If you do not want to store the test, then press the [YES] key. You will continue your testing without your previous audiogram.

The warning message acts as a reminder to store your test if you have not previously done so. It prevents you from losing an audiogram if you have forgotten to store it.

4-2 GROUP 2 - Function Keys

Your Group 2 keys contain several helpful keys which display information on your RA500's screen. The "F" keys will give you the following:

- F1 = Shift Table
- F2 = Display of Baseline Audiogram
- F3 = STS, STS Corrected for Presbycusis and PBI Calculation
- F4 = List of Error Codes
- F5 = Raw Data
- F6 = Future Use

F1

By pressing the [F1] key, you can display the threshold shifts in the baseline vs. current audiogram. A left and right STS average is listed at the conclusion of the audiogram. Follow the screen instructions to exit the menu.

F2

By pressing the [F2] key, the baseline audiogram will be displayed on the screen. To exit this display, press [F2] again and you will be taken back to the main test screen.

F3

When you press the [F3] key, you will see the following calculations applicable to your audiogram:

- STS** - Calculates the STS significant threshold shift for 2, 3 and 4 KHz
 - STS** - Average for both ears.
 - Corrected for Presbycusis** - Lists the Presbycusis correction factor for the audiogram
 - PBI Calculation** - Lists the PBI (Percent Binaural Impairment) calculations for the audiogram
- Press the F3 key to exit this menu.

F4

When you press the [F4] key, it lists the error codes used on the test screen and in the audiogram printout. To exit this menu, press [F4] to return to the main test screen.

F5

When you press the [F5] key, the patient's raw data (the actual responses which lead to establishing a threshold level) can be displayed. A test must be displayed on the main test screen for this key to work. You will note that raw data is displayed to correspond

where the cursor points on the main test screen. Press the [F5] key again to exit this menu.

F6

The [F6] key is used in the delete program (SPECIAL 5, submenu no. 5 - Select Record to Delete). The [F6] key does not have any other purpose in the current RA500 program.

4-3 Group 3 - Print Keys

The keys in Group 3 are as follows:
 PRINT TEST
 PRINT MENU
 PRINT SCREEN

PRINT TEST

By pressing the [PRINT TEST] key, a current audiogram will be printed. If there is no current audiogram entered, the printout will contain no test results. You must be in the main test screen to print your test.

PRINT MENU

When you press the [PRINT MENU] key, the following options are displayed:

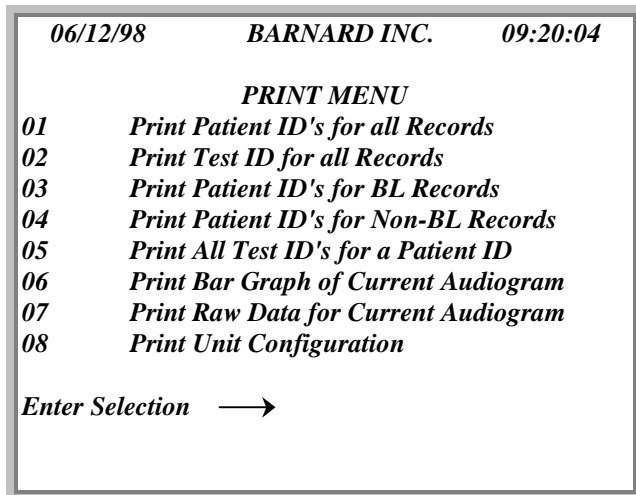

Figure 4-9 Print Menu

4-4 01 - Print Patient IDs For All Records

By pressing the [0] and [1] and [ENTER] keys, all saved audiograms will be displayed by the ID # that was used in the storage. To exit this screen, press the [ENTER] key.

4-5 02 - Print Test IDs For All Records

By pressing the [0] and [2] keys and [ENTER] key, a test ID number for all audiograms that have been saved will be displayed. Each test ID is unique and cannot be duplicated. It contains 16 numbers and the format of the test ID numbers is listed on the following page:

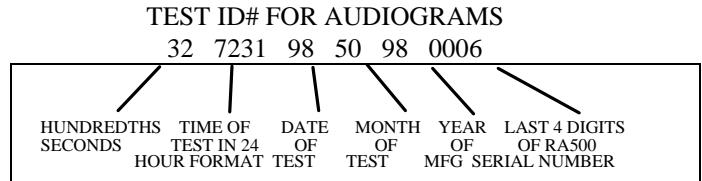

Notice that test ID number data reads backwards. The time, date and individual audiometer make each test ID a unique and different test number from any other. To exit this screen, press the [ENTER] key.

4-6 03 - Print Patient IDs For All BL Records

By pressing the [0] and [3] and [ENTER] keys, patient ID numbers for all baseline audiograms are printed. To exit this screen, press the [ENTER] key.

4-7 04 - Print Patient IDs For All Non BLRecords

By pressing the [0] and [4] and [ENTER] keys, the patient ID numbers for all audiograms not coded as baselines are entered. To exit this screen press the [ENTER] key.

4-8 05 - Print All Test IDs for a Patient ID

Print menu #05 allows you to print out all test ID numbers stored for a particular patient. In this manner, you can print out all test ID numbers for any patient and recall the test by using Special #08.

To begin, press the [0], [5] and [ENTER] keys. Your screen display will show the following:



Figure 4-10 Screen Display for ID Print

When this display appears, type the patient ID number or name. Then press the [ENTER] key. Your printer will print out all test ID numbers stored for your particular patient ID number. If there are no test ID numbers stored, the printer will say "No records

found". Press the [ENTER] key to return to the main test display screen.

4-9 06 - Print Bar Graph of Current Audiograms

By pressing the [0] and [6] and [ENTER] keys, the bar graph of the current audiogram will be printed. This allows you to print a bar graph without printing the entire audiogram. To leave this screen press the [ENTER] key.

4-10 07 - Print Raw Data For Current Audiograms

By pressing the [0] and [7] and [ENTER] keys, the patient response data at each frequency will be printed. This allows you to print the raw data without printing the entire audiogram. To leave this screen press the [ENTER] key.

4-11 08 - Print Unit Configuration

Print Unit Configuration is an easy way to find out how your RA500 is configured. While in the print menu, press the [0] and [8] key. You will see the following printout:

<i>Audiometer Configuration</i>	
<i>Top Test Level</i>	<i>100</i>
<i>Bottom Test Level</i>	<i>-10</i>
<i>Security</i>	<i>N</i>
<i>Bar Graph Print</i>	<i>N</i>
<i>Raw Data Dump Print</i>	<i>N</i>
<i>Print At Test Complete</i>	<i>N</i>
<i>Beep At Test Complete</i>	<i>N</i>
<i>Beep Response</i>	<i>N</i>
<i>Right Ear First</i>	<i>N</i>
<i>Quick Screen</i>	<i>N</i>
<i>Max-Failed Freq</i>	<i>07</i>
<i>Auto Tag on Store Test</i>	<i>Y</i>
<i>Tagged Data Transfer</i>	<i>Y</i>
<i>Auto Dial Mode</i>	<i>N</i>
<i>Test Mode = Pulsed</i>	
<i>Baud Rate A</i>	<i>9600 Baud</i>
<i>Baud Rate B</i>	<i>9600 Baud</i>
<i>PBI Calculation</i>	
<i>AAO (1979)</i>	
<i>STS/Categorization</i>	
<i>OSHA STS</i>	

Figure 4-11 Print Unit Configuration

Items are either listed as Yes (Y) or No (N) or a numerical value (as in the case of Top Test Level, for example). Use of this menu will save you time in finding out how your RA500 is currently configured.

To return to the main test display screen, press the [ENTER] key.

+++ Print menu 01, 02, 03 and 04 allows the operator to set a date range, if desired, and only the records within the date range will be printed.

PRINT SCREEN

The [PRINT SCREEN] key allows you to print anything you see on the screen. The printout will be generated lengthwise for your printer. That's done so you can have all the information displayed on your screen transferred to your printed copy. The only screen displays you will not be able to print are the ones in the print menu and the keyboard test display. In some of the menus, you will need to press the [SHIFT] key and [PRINT SCREEN] key to generate your hard copy. The speed of the print out is slower than in the regular print mode. That is normal, so don't worry about it. Your RA500 has many features found only on a personal computer. This is one of them. Use it anytime you need to generate a printed copy of what you see on the screen.

4-12 Group 4 - Command Keys

The keys in Group 4 are as follows:

NEW TEST	AUTO/MANUAL	YES
RUN TEST	CHANGE EAR	NO
PAUSE TEST	TALK OVER	TONE

NEW TEST

To start your testing you must press the [NEW TEST] key. The screen will ask you - "Proceed to new test, Y/N". Pressing the [YES] key will take you through the menu (follow the directions on the screen) and back to the main test screen display.

RUN TEST

By pushing the [RUN TEST] key your RA500 will begin testing the patient. The test will begin in the automatic mode, but can be paused and used when the machine is placed in the manual mode. When this happens, the test is run in the semi-automatic mode. In this particular situation the test is done automatically only at the selected frequency. (See **Section V** for explanation of testing in the semi-automatic mode).

PAUSE TEST

Your test can be paused by pressing the [PAUSE TEST] key. It will remain in the paused mode until the [RUN TEST] key is pressed.

AUTO/ MANUAL

Your RA500 can be used as a fully manual audiometer by simply pressing this key. Each time you press it, it will switch between automatic to manual mode.

CHANGE EAR

By pressing the [CHANGE EAR] key either ear can be selected. The RA500 will start the test in the left ear, but can be easily changed at any time. Just press the [CHANGE EAR] key at any time (even while testing) to change the ear you are testing.

TALK OVER

When you press the [TALK OVER] key your voice is transmitted to the patient by means of an internal RA500 microphone. If the button is pressed while the test is being conducted the test is stopped and the operator's voice is heard through the patient's earphones. When you release the key, the test continues and the microphone circuit is turned off. You can adjust the output level of the talk-over microphone by going to the set-up options and using Option #20.

YES

-10 dB

The [YES] key has two functions. The first use of the [YES] key is in answering questions from the display screen. When directed by the screen to answer questions in the affirmative, push the [YES] key. Your "Yes" response will be recorded.

The [YES] key can also be used during the manual test mode. You will notice that there is a small (-10 dB) in the lower right corner. This is used to LOWER the threshold by 10 dB at the frequency indicated on the display. This function works only when the manual test mode is selected.

NO

5 dB

As with the [YES] key above, the [NO] key has corresponding functions. If you are in a display sequence where a NO answer is required, press the [NO] key. Your "No" response will be entered on the display screen.

When in the manual test mode the [NO] key can be used to raise the threshold by 5 dB at the frequency indicated on the display screen.

This function works only when the manual test mode is selected.

TONE

Press the [TONE] key while in the manual test mode and you will notice that the word "TONE" is displayed on the main test screen. The test tone will be presented, either in pulsed or continuous mode, for as long as you press down the key.

4-13 Group 5 - The Number Keys

The last group of keys on your RA500 are the number keys (*Figure 4-1*). Actually, several of the keys have multiple uses as you will see. The primary uses for this key group are doing manual entries of baseline audiograms and selecting frequencies during the manual test mode. Let's go over how each of these keys work.

NUMERIC KEYS

The numeric keys are also called multi-function keys. That means one key can do more than one function, depending upon the operation routine or whether the [SHIFT] key is pressed.

These multifunction keys are controlled by the internal microprocessor in the audiometer and will select the proper function depending on the type of data that is being entered.

All of the number keys work as follows:

- A. When entering data such as street addresses, dates, etc., the number indicated in center of the key will be displayed.
- B. When entering test data or doing manual tests, the frequency level as indicated in the lower right hand corner of the key will be displayed.
- C. Using the shift key in conjunction with the number key will perform the function indicated in the upper left hand corner of the key.

In addition, the following keys are used for these purposes:

CLEAR

The [CLEAR] key works as a backspace function. In the data entry mode, you will erase a character each time the [CLEAR] key is pressed. This is helpful when you want to rapidly clear a line you have previously entered.

SPACE 0

The [0/SPACE] key is one that you will use quite frequently if you are using the custom entered question menu. To use the [SPACE] key you must first push the [SHIFT] key (in the supplemental keys - upper left-hand corner), then press the space key. You will notice your cursor moving toward the right. If you do not do this, then this key will revert back to a number entry with a "0" being displayed when the key is pressed.

ENTER

The [ENTER] key is one of the most used keys on your RA500. Many of your data entry functions, special menus and set-up customizing routines will require you to press the [ENTER] key to lock in your selection. By pressing the [SHIFT] and then [ENTER] key, you will be allowed to escape from any data, set-up, or special mode back to the main test display screen. (See *Figure 4-1*). There is one routine where there is no screen display prompt to tell you to press [ENTER]. It is the print menu key. Use this menu as follows:

Print Menu - After selecting one of six desired selections, you must press the [ENTER] key to leave the print menu and return to the main test screen.

How to Conduct an Automatic Audiometric Test with your RA500
Section V

By now you have reviewed your RA500's set-up routine, specials and keyboard layout. As mentioned earlier, there is no substitute for using your new instrument. By practicing set-up, doing specials and trying various custom configurations, you will amaze at how proficient you will become in a short period of time.

Let's do a test. The first thing you do is to reach the main test screen. When you turn the RA500 on, you will see the title format on your display screen, it will look like this:



Figure 5-1 Main Display Screen

To access the main test screen, press any key on your keyboard. You will now see a display that looks like this:

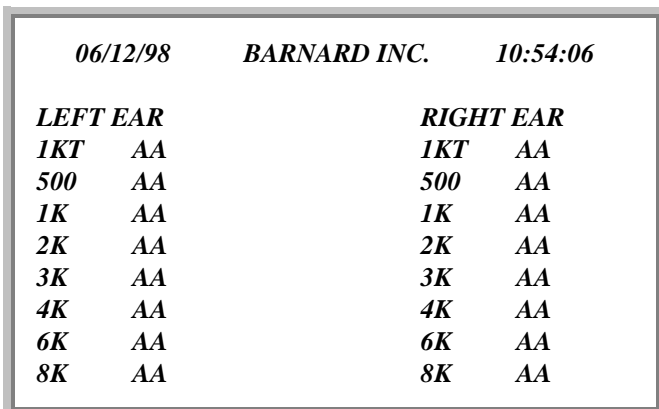

Figure 5-2 RA500 Main Test Screen

If you have not done so already, you will need to custom configure your RA500. Review **Section II** on how to set your instrument up to your own testing requirements.

To start a test, you must first press the [NEW TEST] key. Your display will now read as follows:



Figure 5-3 Proceed to New Test Y/N

If you press the [NO] key, your main test screen will appear again.

If you press the [YES] key the RA500 display screen will present the following:

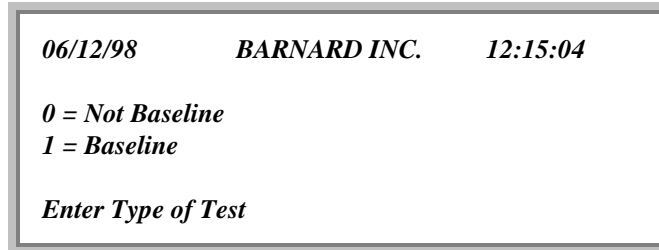

Figure 5-4 Baseline/Not Baseline

Your RA500 is asking you - "will this audiogram be classified as a baseline?" - If it will, press the [1] key and the [ENTER] key. Your display will then read as follows:

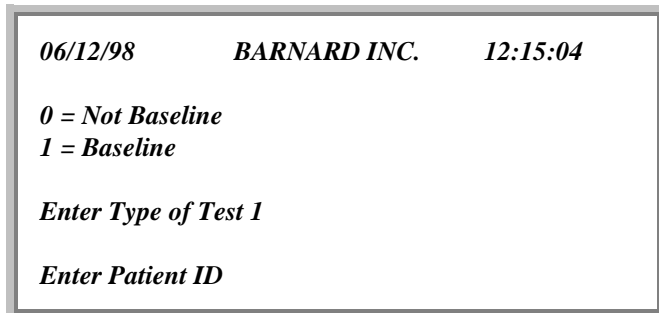

Figure 5-5 Patient ID

Your RA500 asked you to enter the patient ID. It is highly recommended that you use the patient's social security number. This makes it easy to transfer from

your RA500 to a PC using TREMETRICS' FOSHM Occupational Data Management software.

After you have entered your patient's ID number, press the [ENTER] key. You will notice that you are now back at your main test screen. Instruct your subject to press the handswitch and release it as soon as the tone is heard. Your subject **does not** have to wait until after the tone presentation is completed to press the handswitch. To begin your test, simply press the [RUN TEST] key. You will notice that as soon as the key is pressed, the word "TESTING" appears at the bottom of the display screen. The word "tone" is flashed on the screen as the tones are presented to the earphone. When your patient presses the handswitch, the word "response" will appear in the window. It will stay there until the handswitch is released.

You are now in the automatic test mode. The test will begin at 1KHz and proceed through 8 KHz as pictured on your main test screen. Notice that you are able to observe the patient's threshold levels on the main test screen while testing is in progress.

The test paradigm uses the Hughson-Westlake methodology. A 1 KHz validity check compares the first 1 KHz test to the 1 KHz retest. The two thresholds must compare +/- 5 dB. If the frequencies differ by more than +/- 5 dB, the 1 KHz retest threshold is moved to the 1 KHz test. Then "AA" (frequency not tested) code is moved to the 500 Hz and 1 KHz retest. The test restarts at 500 Hz and continues. After completion of the 1 KHz retest the validity check is performed again. If the +/- 5 dB differential continues, then the test stops to wait for the operator.

As you proceed through the test, your RA500 does something else to provide a fast and accurate test. As soon as a patient registers a valid threshold, the tone for the next frequency is presented at a level 10 dB higher than the proceeding one. By using this method, your patient should finish the test faster, especially, if the patient has very good or very poor hearing.

There is one exception to this routine. Your RA500's Notch Adjuster™ test paradigm contains instructions to lower the test tones in certain situations. This will happen at 3, 4 and 6 KHz in either ear.

Some of the more common high frequency losses are those at 3 to 6 KHz. When the patients hearing drops

sharply at one of those frequencies, under the normal routine, the next frequency would be presented at 10 dB higher than the previous one. This could present an uncomfortable situation for the patient if the hearing returns to normal.

If this situation occurs, the RA500 will compensate by returning the next frequency starting tone level to 30 dB. This adjustment provides a more accurate test by limiting the tone to a level closer to the patient's true hearing threshold level.

You may notice that at some point in your testing, your RA500 main test display screen may display the message "ADAPTIVE MODE". This indicates that your patient is responding to tones slowly. The adaptive mode will automatically lengthen the time allowed between the tone presentation and patient response. The adaptive mode will allow your patient to continue taking the test without time consuming operator intervention.

There will be times when a patient will not hear the tone presentation at the highest level for which your RA500 is currently configured. Whatever that level may be, an EE will be registered beside that frequency on the test display screen. In order to calculate the STS, the EE will be recorded as 5 dB higher than the highest level currently set. As an example, let's say that your RA500's highest tone presentation level has been set for 90 dB. A test is given to a patient and no response (EE) is registered at 3 or 4 KHz, both ears. The patient previously has a baseline reading of 70 dB. To calculate the shift, the RA500 records the no response (EE) as 95 dB (5 dB higher than the highest tone presentation level). Subtracting 70 dB (the baseline) from 95 dB (the current test with the "no response") calculates as a 25 dB shift. In this manner, an STS can now be calculated because there are numerical values at 3 and 4 KHz. Remember, your RA500 does all this automatically. You, the operator, need to be aware that the calculations are done even when "no response" readings are registered.

NOTE: The STS calculations in the above situations are estimates only, since it cannot be determined what the actual "no response" reading is. The RA500 calculates the "no response" so that some value may be registered. If the actual value is required, the patient should be referred for further testing.

If you have selected questions for data entry, you will need to go into the data entry screen to enter your

data. To do this, press the key marked [DATA ENTRY]. You will be asked to enter a baseline audiogram, if you have one. Press the [NO] key if you do not want to enter one and the screen will display your questions you have entered and selected. If you want to put your baseline in, press the [YES] key and use the numeric and YES/NO keys [these act as your attenuator) to register your baseline audio. When through, enter the date your baseline was done and press [ENTER] to continue through the Data Entry field.

NOTE: Entering a baseline audiogram in the Data Entry mode does not store in memory. Using the [STORE TEST] key will not store it in memory. The only ways to store baseline audiograms are through the "New Test" and the multiple baseline entry (SPECIAL 13) procedures.

For test validity and calculations, the only questions that need to be answered are:

1. Patient's Name, (last)
2. Patient's Name, (first and middle initial)
3. Patient's Date of Birth
4. Patient's Sex

Questions three and four are used for calculations of presbycusis corrections. No other questions need be entered for valid test calculation results. Your RA500 uses a multi-tasking microprocessor system. You can enter your data before, after or even during the test! If you enter the data and an error condition occurs, your RA500 will immediately return to the main test display screen and the test will stop. The error condition will be displayed in plain English allowing you the chance to take corrective action.

<i>06/12/98</i>	<i>BARNARD INC.</i>	<i>10:54:06</i>
<i>LEFT EAR</i>	<i>AUTO</i>	<i>RIGHT EAR</i>
<i>1KT 10</i>	<i>1KT 10</i>	
<i>500 15</i>	<i>500 10</i>	
<i>1K 10</i>	<i>1K 10</i>	
<i>2K 10</i>	<i>2K 15</i>	
<i>3K 10</i>	<i>3K 10</i>	
<i>4K 10</i>	<i>4K 15</i>	
<i>6K 10</i>	<i>6K 10</i>	
<i>8K 15</i>	<i>8K 10</i>	
<i>Test Complete</i>		
<i>Examiner ID: 2213</i>		

Figure 5-6 Test Complete

When we started doing the test, remember that we were asked if we wanted the audiogram to be marked as a baseline? By pressing the [1] key, the audiogram will be marked as one. When your test is finished, your main test display screen will look like this:

To store your test, just press the [STORE TEST] key. Your screen will now appear with the following message:

<i>06/12/98</i>	<i>BARNARD INC.</i>	<i>10:54:06</i>
<i>LEFT EAR</i>	<i>AUTO</i>	<i>RIGHT EAR</i>
<i>1KT 10</i>	<i>1KT 10</i>	
<i>500 15</i>	<i>500 10</i>	
<i>1K 10</i>	<i>1K 10</i>	
<i>2K 10</i>	<i>2K 15</i>	
<i>3K 10</i>	<i>3K 10</i>	
<i>4K 10</i>	<i>4K 15</i>	
<i>6K 10</i>	<i>6K 10</i>	
<i>8K 15</i>	<i>8K 10</i>	
<i>*** Test Stored ***</i>		
<i>Examiner ID: 2213</i>		
<i>Patient ID: 66321</i>		

Figure 5-7 Test Stored

But what happens if your patient brings you a baseline audiogram from another source and you have to enter it manually? You will need to enter this baseline into your RA500. To do this, you will need to do the following:

1. Make sure you are in the Main Test screen. If you are in another menu, you can get there quickly by pressing the [SHIFT] key, holding it down and pressing the [ENTER] key. This will quickly return you to the Main Test screen.
2. Press the [NEW TEST] key.
3. The screen will ask you - "Proceed to new test"? press the Yes of [Y] key.
4. Press the [1] key to indicate the test is a baseline. After the "1" is displayed on the screen, press the [ENTER] key.
5. Enter the patients ID number or code when it is displayed on the screen, press the [ENTER] key.
6. You are now in the Main Test screen display. To manually enter your baseline audiogram, make sure you are in the manual mode. To do this, press the [AUTO/MANUAL] key in the

command key grouping. Pushing it once will display "MANUAL", pushing it again will display "AUTO".

7. To begin entry of your baseline, press the frequency keys in the numeric keypad grouping (remember, the frequencies are in the lower right hand corner of the 1,2,3,4,5,6,8 and 9 keys). When the arrow cursor points to each frequency, press the [-10 dB] or [+5 dB] keys. They are the ones in the command key group. You will see the -10 dB and +5 dB in the lower right hand corner of the [YES] and [NO] keys. Press these keys to register the correct baseline audiogram threshold. Pressing the [-10 dB] key will decrease the level by 10 dB and the [+5 dB] key will increase it by 5 dB.
8. After you have arrived at the correct baseline threshold for each frequency, press the [ENTER] key. You will notice an "M" displayed after the threshold level. Do this for each frequency until all frequencies have thresholds entered and have "M"'s after each threshold.
9. When you have entered your baseline audiogram results, press the [STORE TEST] key located in the supplemental keys. You will see the following:

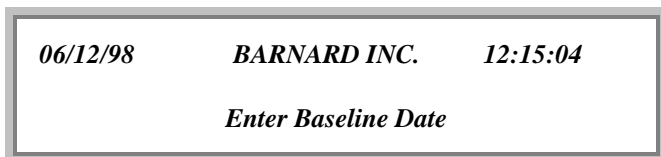

Figure 5-8 Enter Baseline Date

You can enter the baseline test date you want by pressing the appropriate keys on the numeric key pad. Also notice that you do not have to enter the slash bar - the operating system does this for you.

If you want to leave the date the same (the screen will always display the current date), simply press the [ENTER] key. Your baseline is now stored and you are taken back to the Main Test display screen to do your next test.

5-1 How to Do a Manual Test With Your RA500

Manual testing can be done quickly and easily with your RA500. You can test in the manual mode before, during or after you conduct your automatic test.

To do a test in the manual mode, follow these steps:

1. Make sure you are in the Main Test screen (See **Figure 5-2**. RA500 Main Test Screen on page 5-1).
2. Press the [AUTO/MANUAL] key until you notice the word "MANUAL". It will be at the top of the screen between the left ear and the right ear.
3. To select your frequency, press the key with the appropriate frequency. some of the numeric keys have the frequencies in their lower right hand corner. For example, let's say you want to start out testing 2,000 Hz in the left ear. Press the number [2] key (notice that it has 2,000 in the lower right hand corner). The arrow cursor moved beside the "2 K" under the left ear.
4. To set the attenuator, press the [-10 dB] key or the [+5 dB] key. Again you will notice that, as with all dual function keys, there are several items on the same key. In the manual mode, this key serves as an attenuator key only. When a particular frequency is pressed, the attenuator will start at 30 dB. When the [-10 dB] key (the "H" or "YES" key) is pressed, the attenuator is reduced by 10 dB, to show 20 dB at that frequency. Conversely, pressing the [+5 dB] key (the "Q" or "NO" key) raises the attenuator in 5 dB steps. By pressing this key, you will notice that the threshold level is raised 5 dB each time this key is pressed.
5. Conduct your manual test by pressing the [TONE] key. You will see the word "TONE" appearing about halfway down in the middle of the Main Test screen. When your patient responds by pressing the handswitch, you will see the word "RESPONSE" flash on the screen just below the word "TONE". When the patient responds, press the [YES] or [-10 dB] key ("YES" indicating the patient responded). Press the [NO] or [+5 dB] keys when there is no response indication on the Main Test screen.
6. After you have established the desired threshold and want to register it as part of the test, press the [ENTER] key. You will notice that an "M" appears beside the threshold. This indicates that the threshold has been established while in the manual mode.
7. If you want to record the fact that your subject did not respond to the loudest tone generated by the RA500, press the number 7 key on your keyboard. You will notice that an EE is generated inside the appropriate frequency and ear. **Do Not** press the [ENTER] key to enter a "no response". Simply go to the next desired

frequency and repeat the test, or go back to the automatic mode. When "EE" is entered as a test reading, it will assume a value of 5 dB higher than the highest attenuator level for calculation purposes (ie. when the audiogram is retrieved and compared with another test). **NOTE: THIS PROCEDURE WORKS ONLY IN THE MANUAL MODE AND DOES NOT WORK WITH THE SPECIAL 13 MULTIPLE BASELINE ENTRY PROGRAM.**

Select each frequency until you have tested all the frequencies you desire to test. You can print a copy of the audiogram any time you want -- you do not have to be done with your test to print it!

You can go to the manual mode at any time during the automatic test. Just press the [PAUSE] key (you will see the word "PAUSED" at the lower bottom of the screen). Press the [AUTO/MANUAL] key until your screen display says "Manual". Select your frequency on the numeric key pad, adjust your attenuator up or down from the [YES] or [NO] keys, press the [TONE] key and record your threshold levels. To go back to the automatic mode, press the [AUTO/MANUAL] key to where it reads "AUTO", press the [RUN TEST] key, and the test will start back in the automatic mode.

5-2 *How to Do an Automatic Test in the Semi-Automatic Mode*

In addition to the automatic and manual modes, you can also test in the semi-automatic mode. Semi-automatic is a combination of full automatic and manual testing. Semi-automatic testing allows you to pick any frequency in either ear and do a full automatic test for that frequency and that frequency only. The test will stop after the threshold has been established at the test frequency you have selected.

To perform a semi-automatic test you must be at the Main Test screen display. First, press the [PAUSE] key, this will pause your test and you will notice the pause message on the screen. You must also be in the manual mode. To do this, press the [AUTO/MANUAL] key until you see the word "MANUAL" displayed at the top of the screen. Next, select the frequency you wish, by pressing the numeric keys with the appropriate frequency listed in the bottom right-hand corner. You will notice the arrow cursor pointing to the frequency you have selected. You can also select which ear you are testing by pressing the [CHANGE EAR] key.

When you are at the desired frequency and ear, just press the [RUN TEST] key. Your test will start at 30 dB and continue in the automatic mode until the test is complete. When the test is finished, you will notice the "TEST COMPLETE" message displayed toward the bottom of the screen. You will also notice that the test will not continue any further. In this mode, only one frequency will be tested and when it is complete, the test will stop. You are free to continue the test in either automatic, manual, or if you wish to continue, the semi-automatic mode. You can also print the test even if it is not complete by pressing the [PRINT TEST] key. Your audiometric test strip will show only frequencies tested at that point.

The complete RA500 audiogram - "Full OSHA compliance"

Company Name can be Customized at the Keyboard

Date and Time Printed Automatically

Subject ID#

Current Test Results with 1000 kHz Validity Check

Average HL Level 2000, 3000, 4000 Hz

PBI Calculation

Unique Test ID#

Elapsed Time Indicator

Test Mode (continuous or pulsed)

Baseline Audiogram and Date

Calculated Threshold Shifts (corrected for presbycusis)

Serial Number, Software and Hardware Version and Calibration Data

Subject ID# and Signature

Examiner ID# and Signature

TREMETRICS INC.

DATE: 12/19/97
TIME: 16:09:35

PATIENT: 306783606

CURRENT AUDIOGRAM

FREQ	L/DB	R/DB
1000 HZ	00	05
V1000 HZ	05	05
2000 HZ	05	05
3000 HZ	15	05
4000 HZ	20	10
6000 HZ	15	05
8000 HZ	15	05

AVG 2.3.4 011.7 005.0

AAO (1979) CALCULATION
MON LOSS LEFT = 00.00
MON LOSS RIGHT = 00.00
BILATERAL LOSS = 00.00

TEST ID=5390619121090399

ELAPSED TIME = 03:54

TEST TYPE = NOT BASELINE
TEST MODE = PULSED
M = MANUALLY TESTED FREQ

BASELINE AUDIOMETER

FREQ	L/DB	R/DB
1000 HZ	00M	00M
V1000 HZ	05M	05M
2000 HZ	05M	05M
3000 HZ	05M	05M
4000 HZ	05M	05M
6000 HZ	05M	05M
8000 HZ	05M	05M

AVG 2.3.4 003.3 003.3

BASELINE DATE 01/21/82

THRESHOLD SHIFTS

FREQ	L/DB	R/DB
1000 HZ	00	05
V1000 HZ	05	05
2000 HZ	-05	-05
3000 HZ	15	05
4000 HZ	15	05
6000 HZ	15	05
8000 HZ	10	05

AVG 2.3.4 000.3 001.7

STS LEFT EAR = 000.3
STS RIGHT EAR = 001.7

PRESBYCUSIS CORRECTED
STS LEFT EAR = 003.3
STS RIGHT EAR = 000.0

TREMETRICS RA500

SERIAL NUMBER...12900399
SOFTWARE REV. 1.21-00906
HARDWARE REV. H-970915
CALIBRATION: 11/01/97
CAL. ANSI S3.6 1989

PATIENT: 306783606

X _____

EXAMINER: 306762267

X _____

Bar Graph Mode (rapid screening of test results)

Custom Questions and Subject Answers (entered from keyboard)

Raw data printout (legal record of subject's responses)

GRAPH OF LEFT EAR

GRAPH OF RIGHT EAR

QUESTION ANSWERS

LAST NAME: DOE
FIRST NAME: JOHN P.
DOB: 10/31/57
SEX: M
JOB TYPE: SHOP
LOCATION: AUSTIN
PROTECTION: PLUGS
EXPOSURE: 95 DB

RAW DATA DUMP

LEFT EAR 1KT
R 30 R 20 R 10 R 00
R 00 R 00

LEFT EAR 500
R 10 N 00 R 05 N 00
R 05

LEFT EAR 1K
R 15 R 05 N 00 R 05
N 00 N 05 R 10 N 00
R 05

LEFT EAR 2K
R 15 R 05 R 00 R 00
R 00

LEFT EAR 3K
N 10 R 20 N 10 R 15
N 05 R 10 N 00 N 05
N 10 R 15

RIGHT EAR 3K
R 10 R 00 N 00 N 05
R 10 N 00 R 05 N 00
R 05

RIGHT EAR 4K
R 15 N 05 R 10 N 00
N 05 R 10

RIGHT EAR 6K
N 20 N 30 N 40 R 50
N 40 N 45 R 50 N 40
R 45 N 35 N 40 R 45

RIGHT EAR 8K
R 55 N 45 R 50 R 40
R 30 R 20 R 10 N 00
R 05 N 00 R 05

77004-0008
981209

Figure 5-9 Sample Audiogram Printout

***Tremetrics RA500
Advanced Microprocessor Audiometer
Paper Handling/Storage Instructions
Addendum 119147***

Storage Instructions: Thermal paper should be stored in the dark at an average ambient temperature of less than 77°F and a relative humidity of less than 65%. Under these conditions, the paper remains printable for at least 5 years. Also, printed paper, when stored under these conditions, will retain its printed image legibility for a minimum of 7 years or longer.

Thermal paper begins to develop color at about 158°F. However, under humid conditions it might begin to develop at an accelerated rate. If stored for 24 hours at 140°F, the paper shows some signs of development. It also shows signs of development if stored for 24 hours at 113°F and a relative humidity of 90%. As a result of this phenomenon, Seiko Instruments recommends taking precautions and monitoring ambient temperature and humidity if paper is used continuously at temperature above 104°F for more than 24 hours.

Exposure to Sunlight: Thermal paper will yellow if exposed to direct sunlight. Tremetrics recommends keeping unused rolls in their original package. Printed paper should not be left next to a window, rather it should be filed as soon as possible.

Tremetrics does not recommend the use of blue color thermal paper, because the printed image tends to fade in direct sunlight and fluorescent lighting.

Solvent-Based Adhesive: Adhesives containing alcohol or organic solvents and chemicals tend to cause color formation on thermal paper. Rubber-type adhesives should not be used. Starch or PVA-type adhesives are recommended.

Plasticizers: Printed images fade and the image formation ability of unprinted paper is reduced if paper is stored for a long period in files containing PVC film. For storage, files and cases made of polyethylene, polypropylene, polyester, etc., are recommended. Double-sided, self-adhesive tape is recommended for pasting, because most adhesive cellophane tapes contain plasticizers.

Storage With Blueprints: Tremetrics recommends that thermal paper not come in direct contact with freshly developed diazo copying paper. This can cause color formation on the surface of thermal paper.

Surface Handling: Frictional heat on thermal paper causes images to develop. Scratching with any hard metal object, or even a fingernail, can damage the surface and cause image development. A printed image may fade if the image is touched with a wet or dirty finger. It is recommended that the thermal paper be handled in a non-image area.

Handling Summary: A document printed on thermal paper should be placed in a file folder and stapled if desired. The folder should be kept in a file cabinet or desk at office ambient temperature (approximately 72°F). Under these conditions, the image will last for a minimum of 7 years and longer with proper storage and handling procedures.



NOTE

Tremetrics recommends the use of specific thermal paper in order to insure suitable print quality and long print head life.

This paper may be ordered from TREMETRICS by requesting TREMETRICS part number 76498-9008.

USE OF ANY OTHER THERMAL PAPER MAY RESULT IN MARGINAL PRINT QUALITY AND REDUCED PRINT HEAD LIFE. IT MAY ALSO VOID THE WARRANTY.

Loading Paper in Your RA500 Section VI

Your RA500 uses a high quality, archival quality paper designed specifically for the unit. One roll of paper should last for several hundred tests. A stripe will appear at the end of the roll when it is almost done. To replace the roll (use TREMETRICS P/N 76498-9008), do the following:

1. Check to make sure there is no paper left in the printer cavity or a partial piece in the roller section.
2. Pull the paper lever towards you, this releases the pinch roller and allows the paper to be slipped in against the roller.
3. Place a new roll on the black spindle. Place your new roll in the paper supply cavity. Make sure the spindle fits securely in the paper roll holder and that the paper comes off of the bottom of the roll and feeds toward the front.
4. Feed the end of the paper as shown in Figure 6-1, into the paper receiver cavity. The paper should slide under the roller and not the front side. When you see the paper advance out the front of the unit, pull it so that at least two inches are above the test bar.
5. Push the paper lever back away from you. Press the paper feed to insure that your paper advances.
6. You can also place the paper at the start of the paper roller. When the paper contacts the roller, press the [PAPER FEED] key. The paper will then be fed up over the paper cutter.

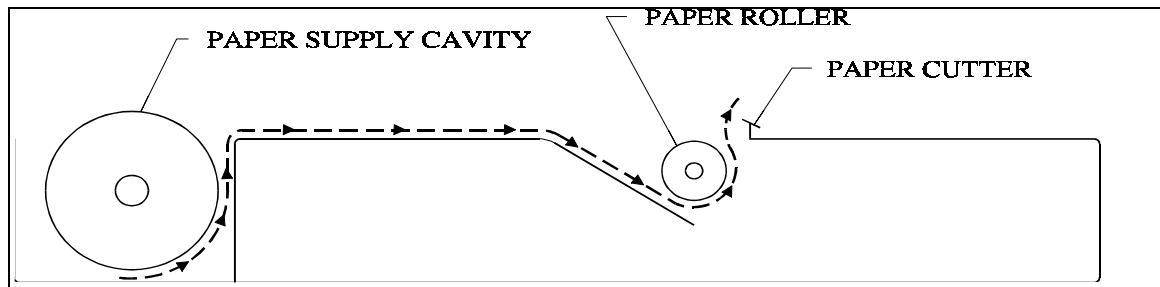

Figure 6-1 RA500 Paper Feed Diagram

Error Codes

Section VII

Your RA500 displays test error codes both on the screen and on the audiometric test strip. They are as follows:

E1	=	1 KHz error
E2	=	1 KHz retest error
E3	=	Response with no tone
E4	=	Rhythmic counting error
E5	=	Frequency retest error
E6	=	Handswitch error
E7	=	Maximum failed frequencies error
E8	=	Hardware error
E9	=	Bad Data
EE	=	No response at the top level
EF	=	Test not complete

Some of these errors will cause your test to pause while others will skip the errored frequency and retest later. The errors that do stop the test will sound the error tone, and the error will be displayed on the main test screen as an error code and in plain text.

E1 - 1 KHz Error - This error message is displayed when your RA500 cannot establish a hearing threshold from the response of your patient. You should reinstruct your test subject on how to take the test, and this will usually cure the problem. Press the [RUN TEST] key to restart your test.

E2 - 1 KHz Retest Error - This error means that your subject has a +/-5 dB differential between the initial 1 KHz test and the 1 KHz validation test. In this error condition, the first 1 KHz test is not correct because your subject may not be familiar with the test procedures. The test is stopped when this happens, and you should reinstruct your subject and press the [RUN TEST] key to restart, this usually takes care of the problem.

E3 - Response With No Tone - The E3 error means that your subject has responded three times with no tone presented. You can either reinstruct or test your subject manually.

E4 - Rhythmic Counting Error - The E4 means your subject is trying to "count down" or guess when the tones are going to be presented. The RA500 can determine this and stop the test. You should reinstruct your subject and continue the test.

E5 - Frequency Retest Error - As explained earlier, the RA500 will retest any failed frequencies after it's tested both ears the first time. If a threshold can not be determined on the second time around, your RA500 will display the E5 error code. If you press the [RUN TEST] key, the RA500 will again try to retest the failed frequency. If this keeps up, you should test your subject in the manual mode.

E6 - Handswitch Error - E6 error means that your subject is not releasing the handswitch. Reinstruct your subject and continue the test by pressing the [RUN TEST] key.

E7 - Maximum Failed Frequencies - If there are more than four failed frequencies in one ear and five in both ears, the test stops and the E7 code appears on the screen. If you press the [RUN TEST] key, your RA500 will go back and retest the last failed frequency. If that retest is successful, the others will be retested as well. You can also retest in the manual mode if the failed frequencies persist. Settable using Set-Up selection 29.

E8 - Hardware Error - If you get this error during your operation, do not use your RA500 any further. Turn it off and call your TREMETRICS Dealer or TREMETRICS. The E8 error means you have a RAM (random access memory) or ROM (read only memory) failure. You could damage your instrument if you do not have the problem corrected.

E9 - Bad Data - - Bad data during transmission or retrieval, data other than that which should appear in the record, did appear. The E9 error acts as a "red flag" that alerts you that a record may have erroneous data. The E9 code will permit "good" records to be transferred without locking or holding up the transfer process. A record which contains E9 may require deletion and manual re-entry.

EE - No Response at the Maximum Level - Error code EE means that your subject is not responding to the tone at the top level you have set. (Remember, you have the power to select what you want your top level to be). You should reinstruct your subject and continue the test by pressing the [RUN TEST] key. (Note: See page 5-2, to see how "no response" readings are used for estimated hearing threshold levels.)

EF - Test Not Complete - Error code EF means that your RA500 is having trouble establishing thresholds

at frequencies other than 1 KHz. There were no thresholds established after 20 presentations. Again, reinstruct your subject and press the [RUN TEST] key to restart your test.

Adaptive Mode - While not an error message, the phrase "IN ADAPTIVE MODE" will sometimes appear on the test display screen. This means that your RA500 is adapting to the response of your subject. Adaptive mode lengthens the response window based upon your subject's responses.

Factory Default System Configuration
Section VIII

The following is a list of how your RA500 is configured as it comes from the factory. You can always go back to these default settings by using the set-up option #18 (set default system configuration).

1. Baud rate -- 9600 baud (both serial ports)
2. Frequencies -- All frequencies selected
3. PBI calculation -- None enabled
4. "Beep" response for keyboard -- Enabled
5. Pulsed or continuous tone -- Pulsed
6. Top test level -- 100 dB
7. Bottom test level -- 0 dB
8. Select beep at test complete -- Enabled
9. Select bar graph print of audiogram -- Disabled
10. Select raw data dump print - Disabled
11. Select audiogram print at completion of test-- Disabled
12. Talk-over output level -- Set at highest level
13. Select the right ear first -- Disabled
14. Display adjust -- Setting # 25 (mid-range)

Interfacing to PC
Section IX

Before data can be transferred to an external PC, connect a cable from rear panel connector of RA500 to communication port of PC. Use Port 1 connector (25-Pin) on RA500.

Data to the PC must be transferred to a PC based Hearing Conservation Program such as Tremetrics FOSHM Software.

NOTE: Several problems may arise causing non-transfer of data to PC: baud rates, internal

modems, PC operating speed, memory resident programs and defective cables.

If the PC has a 25-Pin Com Port, use a 25 to 25-Pin Serial Cable (25m to 25f) P/N 76396-0026. If the PC has a 9-Pin Com Port, use a 25 to 9-Pin Serial Cable (25m to 9f) P/N 76396-0030. The Serial Cable, also known as a modem cable, can be purchased at your local computer store or from Tremetrics.

Refer to operating instructions for the individual software for additional information on audiogram transfers.

**Operation with Tremetrics AR9S
Soundroom
Section X**

You may wish to operate your RA500 Audiometer in conjunction with a Tremetrics AR9S Soundroom. To connect your RA500 to the AR9S you will need two patch cables. If you purchased your RA500 with your AR9S, the cables are supplied with the soundroom. If you purchased the AR9S by itself, you will need two(2) 3-wire patch cables. These can be purchased from Tremetrics as part number 24115-0002.

To connect the audiometer to the soundroom, plug one cable into the jack (receptacle) in the rear panel of the audiometer marked "Headphones". Then plug

the other cable into the audiometer jack marked "Handswitch".

Now take the other end of the cables you have just installed and plug them into the soundroom jack panel. You will notice that the AR9S jack panel has four receptacles. You can plug the two patch cables into any of the four. However, in order to be consistent, it is better to have one standard way so that it is easier to reconnect if the cables are removed.

Connect the headset and handswitch to the corresponding jacks on the inside jack panel, and you are ready to begin using your AR9S.

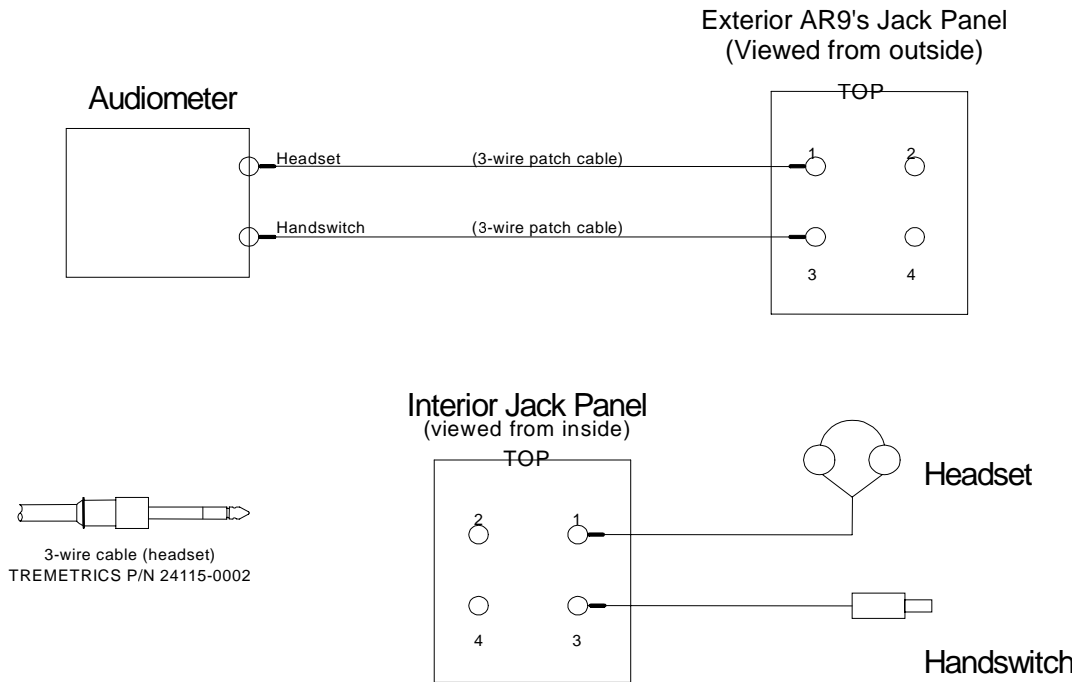

NOTE: Numbers on jack panel sketches shown for reference only, and do not appear on actual parts on soundroom.

Any connection configuration will work as long as the proper cable matches the appropriate receptacle in which the Headset/Handswitch is connected.

What to Do if Something Goes Wrong
Section XI

Your TREMETRICS RA500 Advanced Micro-processor Audiometer is the result of thousands of hours in testing, engineering and design. However, there may be times when you encounter a problem. The following is a brief summary of problems you may encounter and what to do to correct the problem.

PROBLEM	SOLUTION
1 . Power does not come on.	Unit plugged in? Unit turned on? Check fuse (internal).
2 . Skips frequency during automatic test	Was frequency deleted? Check set-up #7.
3 . Power comes on, but no display	Press display adjust, unit will automatically go to display position #25 (mid- range).
4 . Left and right tone on same ear	Earphone plug may not be plugged in all the way.
5 . Response light stays on	The earphone has been plugged into the hand-switch jack.

