

C-Flow Coriolis Mass Flow Meters



Ready for Take Off
The New Compact C-Flow



Küppers Elektromechanik GmbH

The C-Flow

The C-Flow Coriolis Mass Meters consists of two components:

KCE Transmitter



KCM Transducer

Application and Features

- For fluids (e.g. PU components, paints) and gases of high density
- Suitable for aggressive and contaminated media
- Measurement of mass flow, density, temperature and volume flow
- Excellent purging and sterilization qualities due to a construction free of dead spots
- Up to +125°C medium temperature
- Individual 8-point-calibration including report
- Ex protected as per ATEX and EMC tested
- High rotation frequency and well-balanced measuring pipes

Special features:

- Pmax. 350 bar
- Short response time
- DKD calibration

Principle

Two parallel arranged pipes are rotated at their resonant frequency by coils. Any mass flow passing through the tubes will generate coriolis forces which appear whenever a mass moves radially in a rotating system. The forces have opposed effects on the in- and outlet side, they do slightly deform the pipes. The excursion of the pipes is detected by sensors on the in- and outlet side. The phase shift between the rotational frequencies of both pipes is proportional to the mass flow rate.

The resonant frequency of both pipes changes in accordance with the density of the medium. This effect is used to determine the density.

The extent of deformation of the pipes depends on temperature. Therefore the temperature is measured for compensation purposes.

Using only one sensor primary values as mass flow, density and temperature can be measured. Conversions allow for calculation of further values like flow volume and concentration.

Cycle of excursion (simplified)

Rotation and deformation of two parallel looped pipes by the coriolis force F_c .

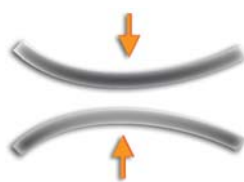

Movement to the inside
no flow

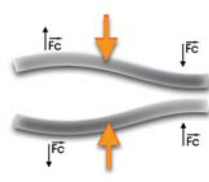

Movement to the inside and
 F_c direction with flow

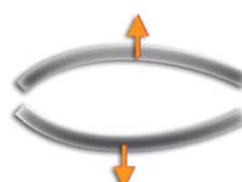

Movement to the outside
no flow

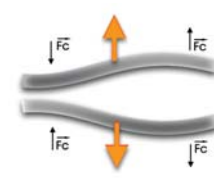

Movement to the outside and
 F_c direction with flow

KCM Transducer

Type	Internal dia	Meas. range, kg/h	kg/min
KCM 0300	4 mm	4.5 up to 300	0.075 up to 5
KCM 0600	4 mm	9.0 up to 600	0.15 up to 10
KCM 1500	8 mm	25 up to 1,500	0.40 up to 25
KCM 3000	8 mm	50 up to 3,000	0.90 up to 50
KCM 6000	12 mm	60 up to 6,000	1 up to 100
KCM 20K	18 mm	200 up to 20,000	3.3 up to 334
KCM 40K	28 mm	400 up to 40,000	6.7 up to 667
KCM 60K	34 mm	600 up to 60,000	10 up to 1,000

Technical Data – KCM 0300 to KCM 3000

Medium temperature:	up to +125°C
Connections:	<ul style="list-style-type: none"> • female threads G1/2" • adapters for flanges, diary or tri-clamp connectors
Operating pressure:	max. 350 bar
Material:	stainless steel as per DIN 1.4571 (AISI 316 Ti)
Ingress protection:	IP 67
Electrical connection:	<ul style="list-style-type: none"> • 9-pin flange plug • compact version with integral transmitter
Max cable length:	30 metres between transducer and transmitter
Ex-protection:	EX II 2G EEx Exd (ib) IIC T2–T4 TPS 07 ATEX 1 282 X
Weight:	KCM 300 and 600: 4.1 kg KCM 1500 and 3000: 8.8 kg



Technical Data – KCM 6000 to KCM 60K

End connections:	flanges according to EN 1092, ANSI B16.5, DIN2512
Nominal pressure:	PN 40, ANSI 150/300 lbs
Process temperature:	-40°C up to +180°C
Ambient temperature:	-40°C up to +60°C
Ingress protection:	IP 65 (EN60529) (NEMA 4X)
Materials	flow tubes, splitter flanges: 1.4404 (316 L)/1.4571 (316 Ti) housing: cast iron



Accuracy

Type	KCM 300	KCM 600	KCM 1500	KCM 3000	KCM 6000	KCM 20K	KCM 40K	KCM 60K
No. of measuring tubes (arrangement)	2 (serial)	2 (parallel)	2 (serial)	2 (parallel)	2 (parallel)	2 (parallel)	2 (parallel)	2 (parallel)
Basic error (referring to instant. flow)	±0.5%	±0.5%	±0.5%	±0.5%	±0.5%	±0.5%	±0.5%	±0.5%
Zero stability	0.05 kg/h	0.12 kg/h	0.3 kg/h	0.5 kg/h	0.6 kg/h	2.0 kg/h	4 kg/h	6 kg/h

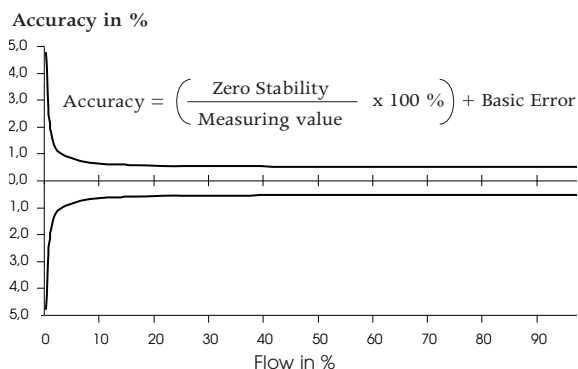

The diagram shows typical values. Individual values may be taken from the calibration records supplied with each meter.

KCE 5000 Transmitter

General

Display:	multi-line
Supply voltage:	24 VDC, $\pm 15\%$
Programming:	via front keyboard and with magnet
Interface:	RS 485 or RS 232
EMC:	according to EN 50 081-2 and EN 50 082-2
Power consumption:	max. 2.5 W



Exd housing

Features:	painted blue with transparent cover
Connections:	1/2" female NPT cable gland
Material:	aluminium diecast
Protection class:	IP 68
Weight:	approx. 2 kg
Temperature:	storage and transport: 0 up to 40°C operation: -20 up to 50°C



Panel-mounted housing

Dimensions:	96 x 96 x 155 mm (h x w x d)
Connections:	rear screw terminals
Protection class:	front: IP 60, rear: IP 30
Weight:	approx. 500 g
Temperature:	storage and transport: 0 to 40°C operation: 0 to 50°C



Analog Outputs

Two current outputs:	4–20 mA passive, two-wire isolated
Resolution:	14 bit
Linearity:	$\pm 0.05\%$ of final value
Temperature drift:	0.05% per 10 K
Load:	< 800 Ω
	scaled output of flow rate or job total, density or temperature

Pulse Output

Frequency range:	0.5–5,000 Hz
Output signal:	active push pull output of flow rate and/or cycle output

Status In- and Output

Status output:	fault out info (push pull)
Status input:	offset start active (push pull)

Dimensional drawing (mm) KCM 0300 to KCM 3000

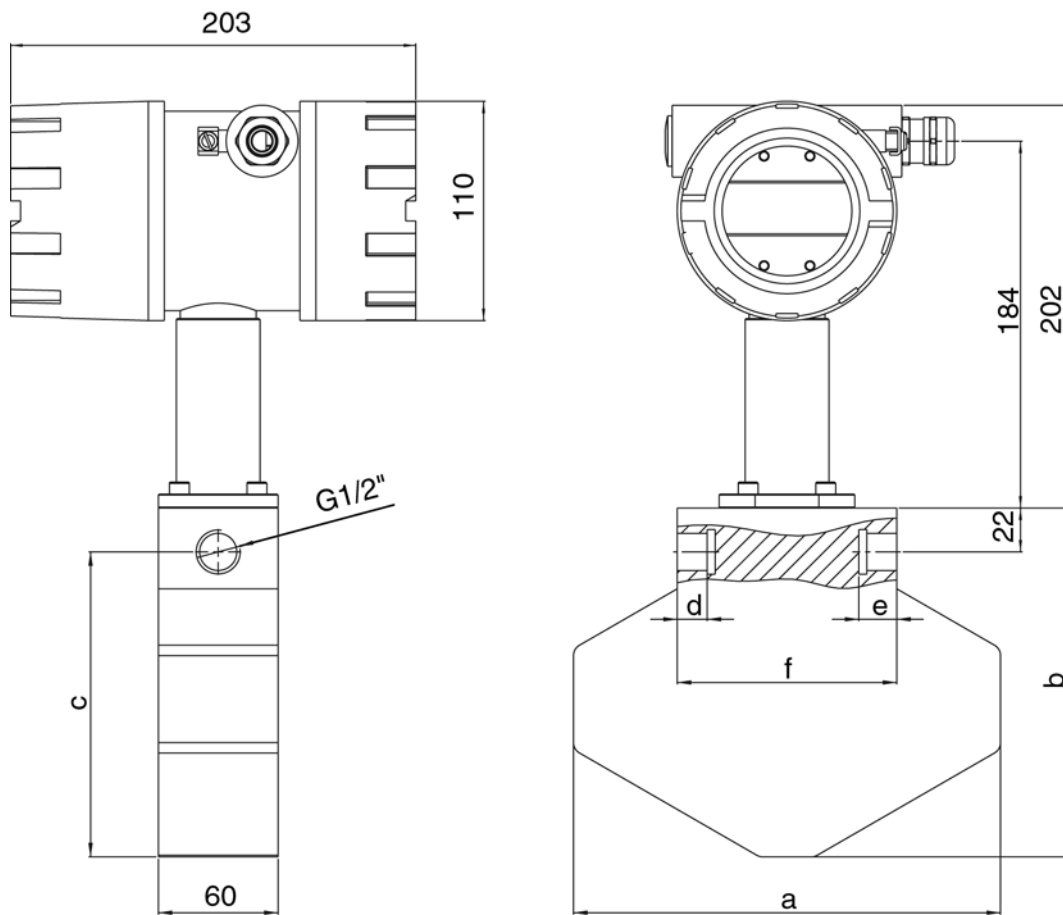

Type	a	b	c	d	e	f
KCM 0300	214	182	160	15	19	110
KCM 0600	214	182	160	15	19	87
KCM 1500	350	280	258	18	21	140
KCM 3000	350	280	258	18	21	140

Dimensional drawing (mm) KCM 6000 to KCM 60K

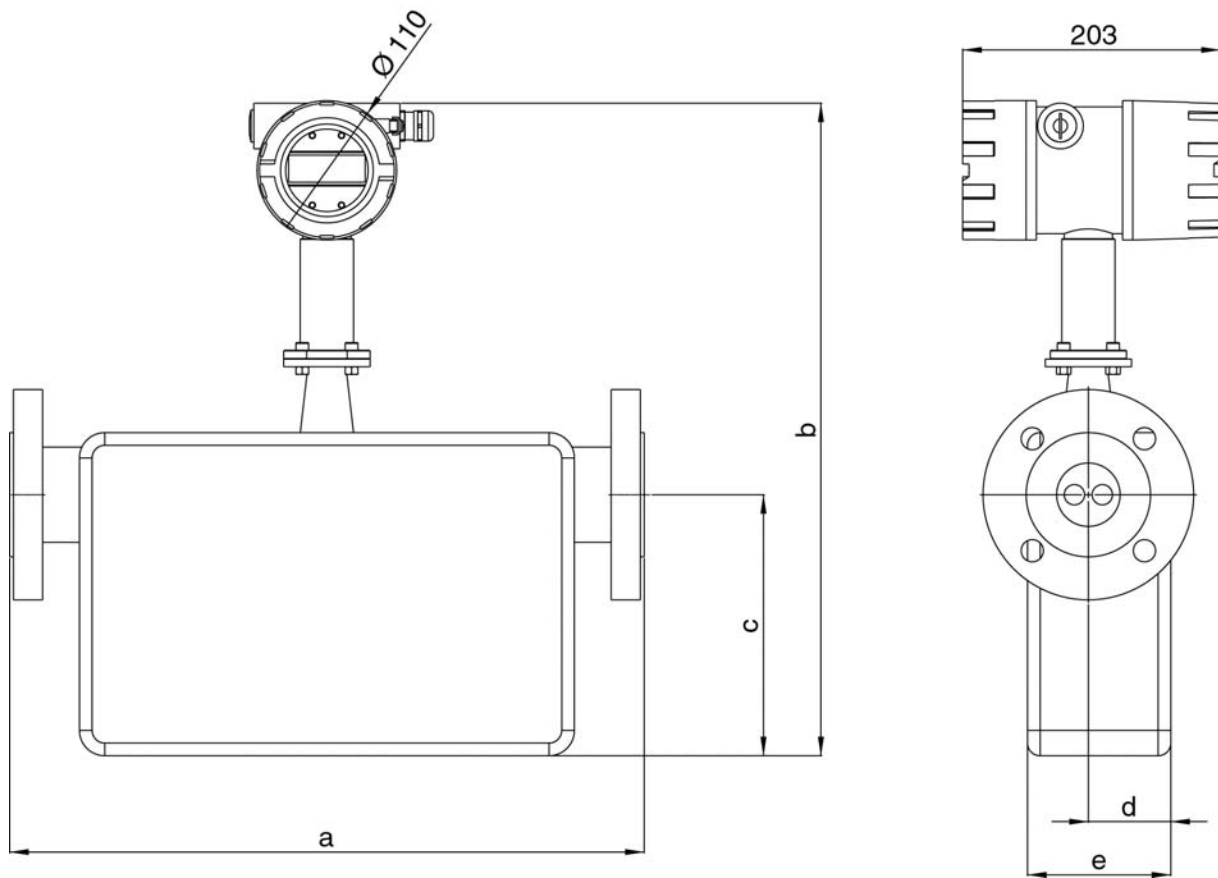

Type	a	b	c	d	e	flange ends
KCM 6000	400	465	173	65	113	DN 25 PN 40, ANSI 1" 150/300 lb
KCM 20K	500	506	206	65	113	DN 50 PN 40, ANSI 2" 150/300 lb
KCM 40K	600	592	290	77	137	DN 80 PN 40, ANSI 3" 150/300 lb
KCM 60K	600	592	290	77	137	DN 80 PN 40, ANSI 3" 150/300 lb

Dimensional drawing (mm) Wall-Mounted Housing

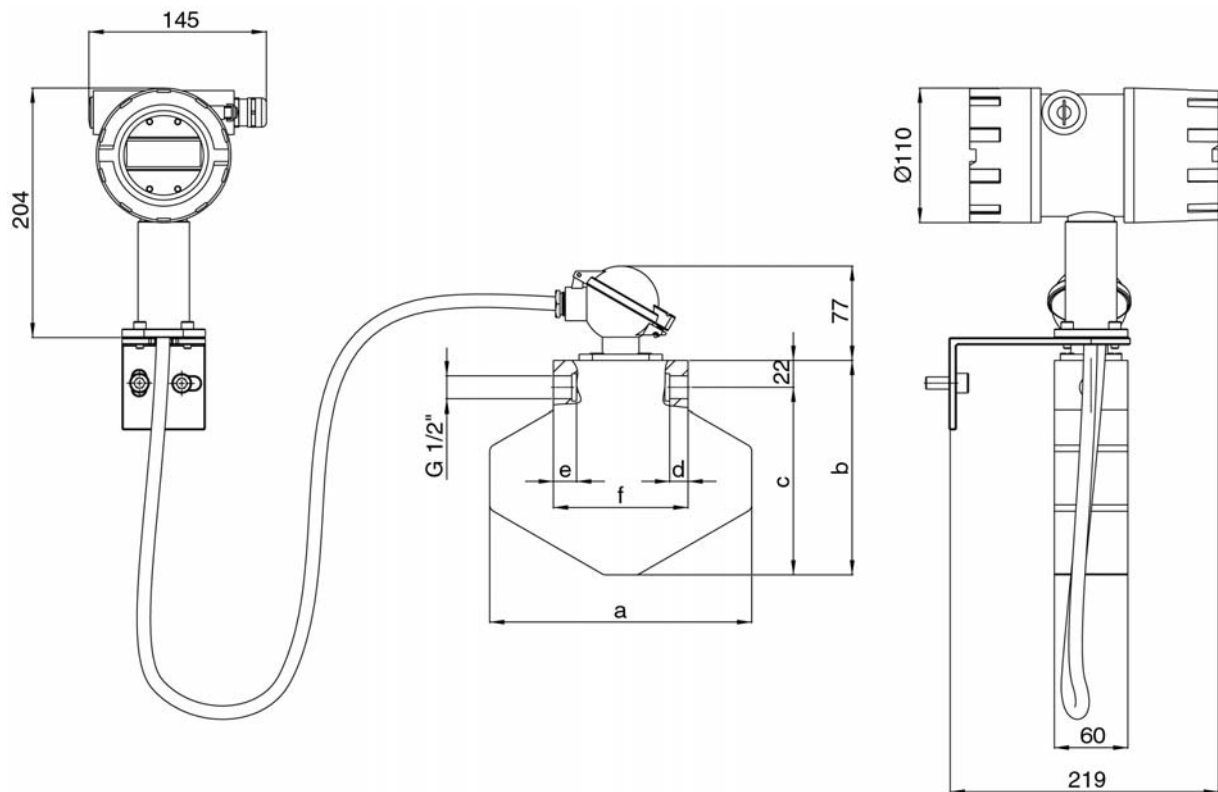

Type	a	b	c	d	e	f
KCM 0300	214	182	160	15	19	110
KCM 0600	214	182	160	15	19	87
KCM 1500	350	280	258	18	21	140
KCM 3000	350	280	258	18	21	140

Dimensional drawing (mm) Panel-Mounted Housing

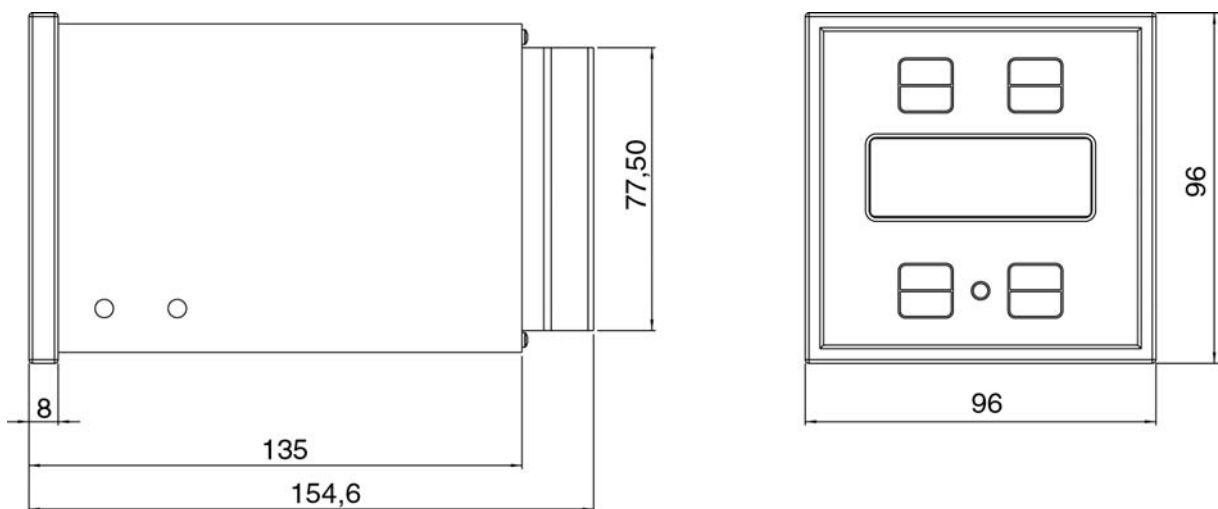

Pressure drop

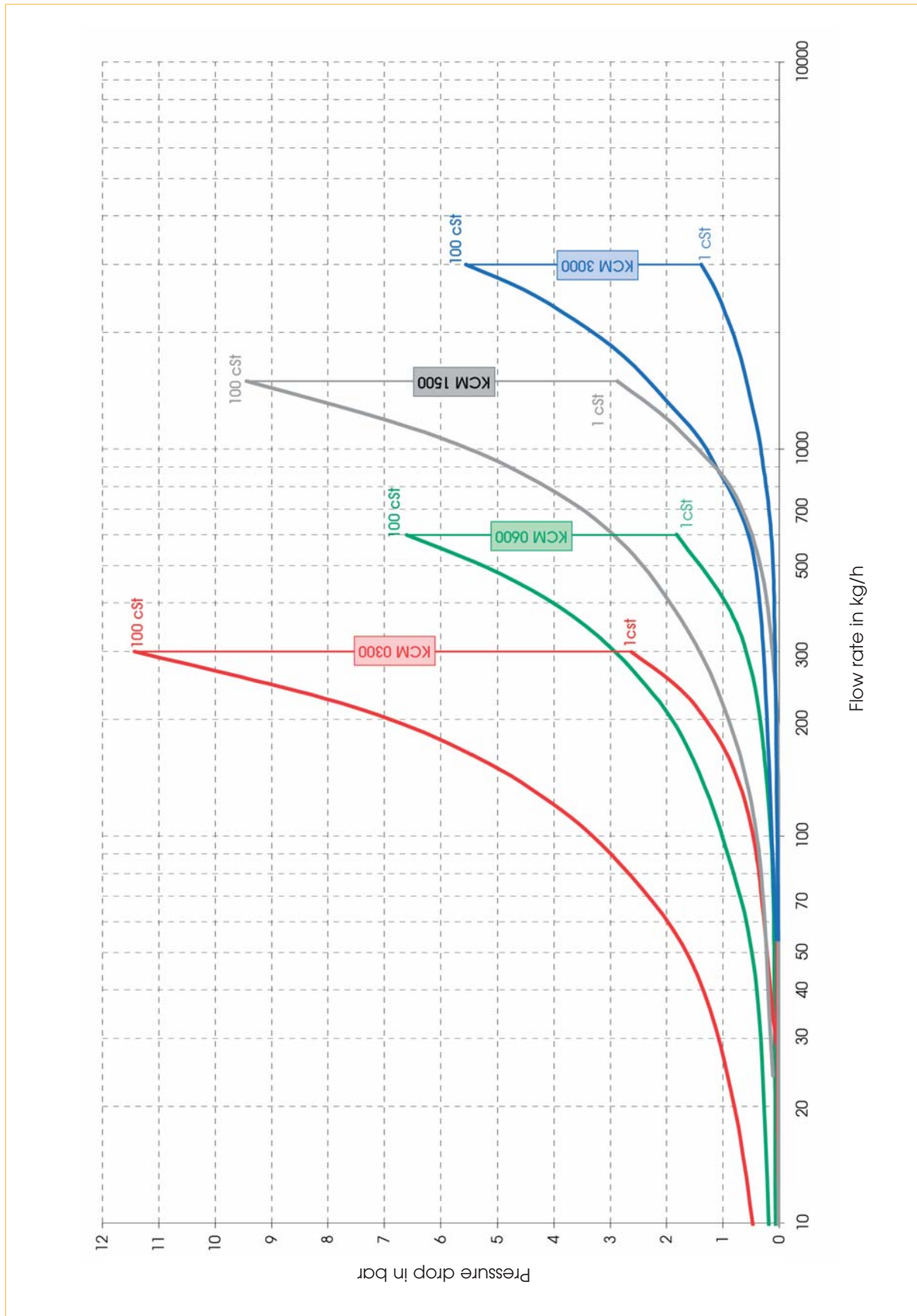

Overview



Compact version
with female threads
and Exd housing

Compact version
with flange ends
and Exd housing



Exd Housing for wall-mounting

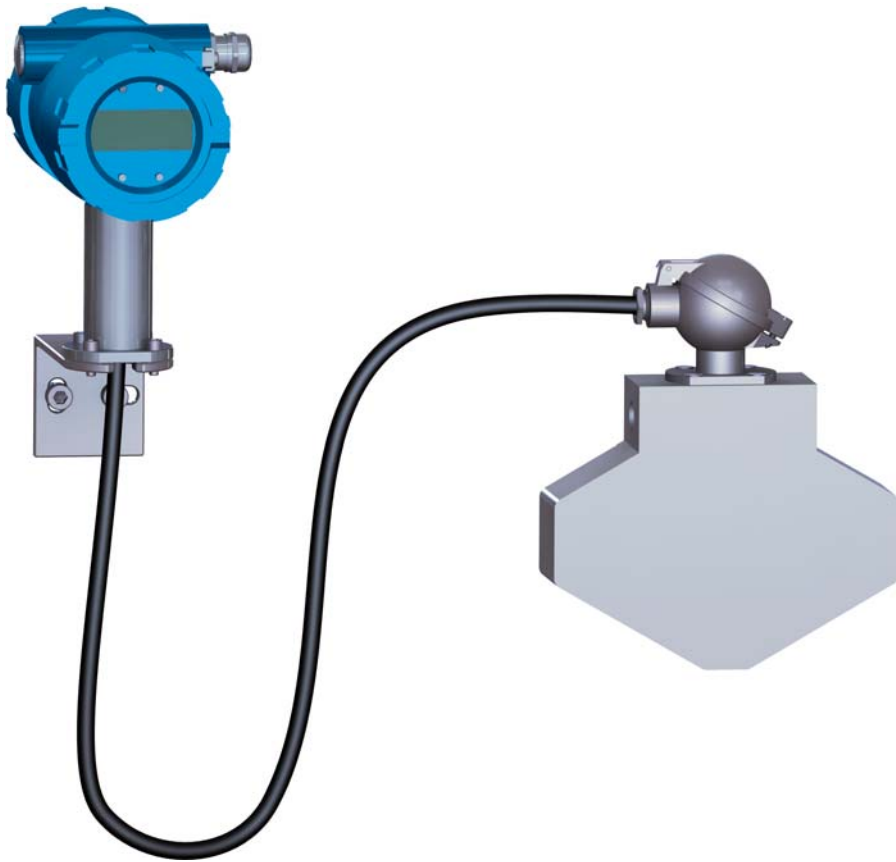

Remote Panel-mounted housing





BELL
Flow Systems
www.bellflowsystems.co.uk

