

CALEC® ST

Multi-protocol heating and cooling energy calculator

Application

Top quality heat and cooling meters for heating, air-conditioning, cooling and solar energy plants can be realised with the CALEC® ST energy calculator. The modular unit distinguishes itself by its long-term stability. Flexible communications makes it particularly interesting for integration into building management systems.



Characteristics

- Precise measurement of thermal energy for heating, cooling and combined heating/cooling plants
- Interfaces to building control systems: M-Bus, LON, Modbus, N2Open
- Plug-in calculator module
- Data for standard cooling media with variable properties
- Integrated power supply for flow sensor
- Up to 2 pulse in-/outputs or 2 analogue outputs
- Metrological approval in accordance with 2004/22/EC (MID) and PTB K7.2 (cold, heat/cold combined)

Customer advantages

- Precise energy measurement for all thermal applications in buildings engineering
- Measurement of "heating and cooling" in a single unit
- Use in cooling and solar heating systems
- Choice of power supplies
- Re-calibration saves process costs
- Supports operation monitoring
- Expandable on modular basis
- Optimum LON system integration
- Added logistical value thanks to optional on-site programming of pulse value and installation site of flow sensor (INIT mode)

Application

The CALEC® ST is used for energy metering in split configuration with passive impulse-generating volume-measuring elements and P t100 or Pt 500 temperature sensors in two- or four-wire version. In most cases, CALEC® ST is used with the following volume-measuring elements:

- Multibeam meters in the range Q_p 0,6 - 10 m³/h
- Hydrometric vane in the range Q_p 15 - 600 m³/h
- Static volume-measuring elements up to Q_p 0.6 - 6'000 m³/h

Choose from our wide range of volume-measuring elements. Our advisers will be pleased to help you select the right ones for your needs.

Obligatory calibration and type-approval

In most countries energy metering systems used for commercial purposes are subject to compulsory verification. The devices comprising the metering system must all possess official pattern approval. CALEC® ST has been approved according to both the European Measuring Instruments Directive 2004/22/EG and the German PTB K 7.2 directive for cooling meters.

Officially verified heat meters must be reverified before the verification period has expired. The operator is responsible for compliance with this requirement. (Re-)Verification includes all parts (temperature and flow sensors, calculator) forming the complete heat meter. The plug-in calculator module considerably reduces the cost of reverification since there are no wires to be disconnected.

For testing and reverification purposes a high resolution display mode as well as CALEC® Win K are available.

New: Commissioning of officially verified devices is even easier as both the pulse value and the installation side can now be programmed in situ (INIT-Mode).

Basic function and measuring principle

A so-called "combined" heat meter requires the following individual devices:

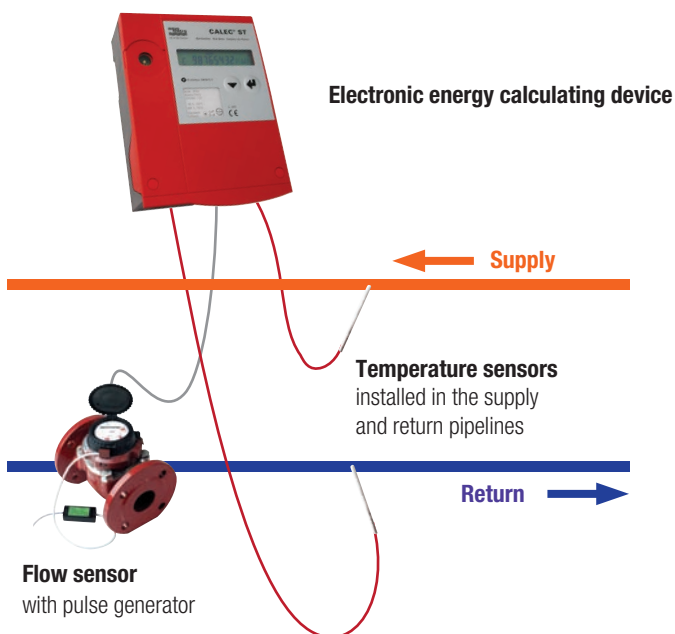

The thermal output (P) of a pipe-conduit network is based on a measurement of the flow temperature, return-flow temperature and volume flow of the heat transfer medium.

$$P = \text{Volume rate of flow} \times (T \text{ heat side} - T \text{ cold side}) \times k$$

T heat side: For heating, flow temperature, for cooling, return temperature
T cold side: For heating, return temperature, for cooling, flow temperature
k: Heat coefficient (function considering temperature and pressure-related characteristics of the heat carrier)

Energy can be determined by integration of output. The formula shows that, in order to meter energy, the specific heat and density of the heat transfer medium must be expressed in relation to the temperature of the counter mechanism. The following factors (among others) also have a decisive influence on metering accuracy:

- The static accuracy and stability of the temperature-measuring procedure
- The counter cycle of the temperature-measurement system, and the volume flow used to detect dynamic factors

CALEC® ST is ideally equipped for use in demanding metering tasks, thanks to:

- The use for temperature-measuring purposes of a high-resolution AD converter (16 bit) designed with long-term stability in mind and equipped with self-calibration and filter functions
- Short counter-cycle (mains version: 1 s)
- The ability to use high-resolution mechanical or electronic flow indicators operating at pulse frequencies of up to 200 Hz (mains version)

Flow-rate measurement

The system is compatible with all standard flow meters that work on the pulse output principle. Adjust the pulse value to the lowest possible setting if you do require continuous measurement or high-resolution energy metering.

When it is running on battery power, the CALEC® ST can handle contact makers working at pulse frequencies of up to 6 Hz. The mains-powered CALEC® ST can operate with contacts makers running at up to 20 Hz and electronic transmitters (NAMUR, etc.) with pulse frequencies of up to 200 Hz.

The point of installation of the flow-rate meter is of vital importance, as the volume-to-mass conversion is based on the temperature detected at this point.

It is preferable to fit the flow indicator to the section of conduit where the temperature is nearest to room temperature.

Temperature measurement

The CALEC® ST is fitted with two highly-accurate temperature-measurement inputs, which are each connected to type-approved, paired temperature sensors in two- or four-wire configuration. The planning of systems should conform to heat meter standard EN 1434, parts 2 and 6. EN 1434-4 stipulates that only sensors of the same design and length should be paired together.

The counter mechanism is available in either Pt 100 or Pt 500 configuration.

Thermal energy is measured from a temperature difference from dT above (respectively below) 0 K. The CALEC® ST is the ideal solution for air-conditioning or cooling installation when used with appropriate temperature sensors and flow meters for cooling.

Data communication

M-Bus Interface

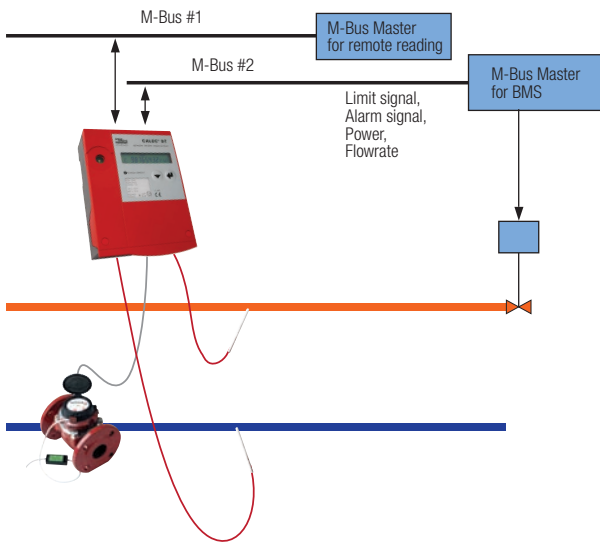

On account of its standardisation (EN 13757) and features as readout bus for building management systems (BMS), M-Bus has been used as the communication protocol in many instances. Advantages include:

- easy installation
- high cost-effectiveness
- multi-vendor capability.

Not only standard data such as meter readings and current values can be read out over the M-Bus interface, but also all additional data available from the device, for example billing and logger values. With CALEC® ST primary addresses and baud rates can be set with the operating keys, eliminating the need for a PC when commissioning the system.

M-Bus is a single master bus, meaning that a slave can communicate with only one master. If device data are to be transmitted to two M-Bus masters then this will only be possible with devices having two M-Bus interfaces. In such cases CALEC® ST can be fitted with a second M-Bus interface.

LON interface

A LON network can combine BMS and meter readout in one system. LON (Local Operating Network) is a multi-master system with intelligent nodes which can use different transmission media. For CALEC® ST a LON interface (FTT-10A) for transmissions over twisted pair cabling is available. An outstanding feature of the LON technology is its interoperability which guarantees that the BMS remains operational beyond the service-life of its individual components. CALEC® ST is the first energy calculator to be certified according to LonMARK® 3.4. This means lower costs and reduced delivery date risks for system integration. LonMARK® 3.4 certification means, among other things:

- Assurance of communication functionality and data availability
- Low integration costs since standard tools can be used and all features required by LonMARK® are available (object library, XIF files, service LED, service key, etc.).

Modbus RTU interface

The Modbus interface allows direct connection of CALEC® ST to a Modbus controller. The Modbus protocol as de facto standard in control and building management systems is widely used since it is an open protocol (www.modbus.org). It is based on a master/slave architecture and allows for a simple system integration by means of a mapping table. Modbus RTU uses the physical layer of the RS485 interface. Further information can be found in the operating instructions (Art. No. 20891).

N2Open interface

CALEC® ST can communicate directly with N2Open controllers (e. g. from the JCI company) by means of the N2Open interface. N2Open also uses the physical layer of the RS485 interface. Further information can be found in the operating instructions (Art. No. 20892).

Digital inputs and outputs

The CALEC® ST can be fitted with two digital-signal interfaces, which can be configured - by means of a switch - as either inputs or outputs. These signals can be used to process counter impulses, or to warn when limit values have been exceeded, or to transmit alarm messages to the building-management system.

Limit-value signals

Digital output signals can be used to emit limit-value monitoring signals. The following parameters can be monitored in this respect:

Factor	Display
Temperature on "hot" side	t-hot
Temperature on "cold" side	t-cold
Temperature difference	t-diff
Output	POUEr
Flow rate	FLOU
C-factor	C-Factor
Density	dEnSitY

1. Function of one-sided limit-value monitoring (Limit1)

If an adjustable maximum limit is exceeded **or** if the reading fails to reach an adjustable minimum, the output signal switches over, hysteresis (0 - 10 %) and control direction are selectable as required. While the excess-reading remains in force, the meter (showing "Cnt" for "counter") calculates the total duration of the error for inspection purposes.

2. Function of two-sided limit-value monitoring (Limit2)

If an adjustable maximum limit is exceeded **and** if there is failure to reach an adjustable minimum, the functions operate in a similar way to those of Limit1.

Alarm message

The microprocessor monitors the temperature sensor and internal functions, and displays any resulting error messages. This information can also be used to generate an alarm signal via the digital outputs.

Analogue outputs

CALEC® ST can be equipped with two passive analogue outputs. An external power supply is required for operating purposes. The outputs are electrically isolated from each other and from the counter mechanism. The current per channel can be adjusted within a range of 0 - 20 mA or 4 - 20 mA. The following readings can be emitted as current signals:

Reading	Display
Temperature on "hot" side	t-hot
Temperature on "cold" side	t-cold
Temperature difference	t-diff
Output	POUEr
Flow rate	FLOU
C-factor	C-Factor
Density	dEnSitY

Additional functions

Crucial-date factors

Two freely-programmable crucial dates (e.g. March 31st and September 30th) can be entered into the metering system and checked at any time.

Data logging

The CALEC® ST can periodically save up to 60 data records in a circular buffer.

Factor	Display
Date	-
Energy	Total
Volume	Total
Auxiliary meter 1	Total
Auxiliary meter 2	Total
Output	Peak value
Downtimes	Total

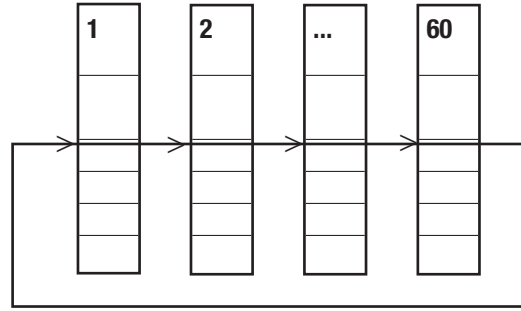

Simultaneous readout

In a plant with many meters, a considerable time difference between readings can occur if these are read out sequentially. CALEC® ST avoids this problem with the "Freeze" command. A broadcast command instructs all meters simultaneously to store the required value after which they can be read out sequentially.

Low-flow OFF function

The system is factory-adjusted to carry out an energy calculation as soon as a temperature difference of >0 (when measuring heat) or <0 (when measuring cold) is detected. If, for example, a circulation conduit carries, over a long period of time, large quantities of heat transfer medium with a very low temperature difference, this can lead to significant reading errors in temperature measurement. The so-called "low-flow OFF function" can be activated to avoid this, ensuring that energy is only detected when a pre-defined temperature difference is exceeded.

Special functions

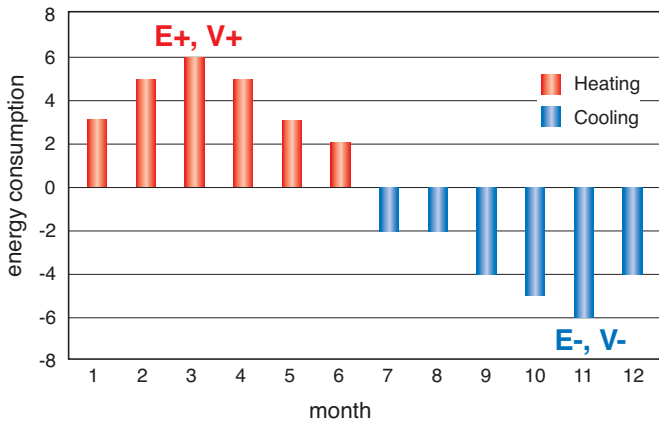

Energy metering in heating/cooling systems

The "bi-directional energy metering" (BDE) option allows emitted energy to be metered even in twin-conduit networks that perform a combined heating and cooling function. The measurement readings for heating and cooling are recorded separately for their corresponding cost-calculation purposes.

Recording of "heat return"

The "Tarif Return Limit" (TGR) option can be used to set a programmable limit for the return temperature of the heat quantity. If this limit is then exceeded, the flow is "returned" to the supply network and thus reduces efficiency.

Heat carriers with frost protection additives

The below-freezing temperatures involved in running a refrigeration plant require the use of additional frost protection. This poses an insurmountable problem for many conventional heat meters, as has been investigated in detail in such publications as PTB Report PTB-ThEx-24 of June 2002.

The "Glycol-based heat transfer medium" option available with CALEC® ST ensures that metering is accurate even in these situations, as energy and volume can be calculated with a sliding scale of values for density and heating capacity for each temperature, independently of that temperature. CALEC® ST gives accurately polynomial readings for the physical characteristics of 11 widely-used heat transfer liquids with respect to concentration and temperature (see following table).

Only the heat transfer medium and concentration are established at start-up (see table):

Medium 4)	Display	Concentration	Temperature range	Manufacturer	Type	Application/observations
Antifrogen N	AntifroN	20 - 60 %	-120 °C ¹⁾	Clariant	E ²⁾	Confirms to DIN 4757-1; toxicity class 4 For cooling, solar, heating and heat pump systems Low viscosity, requires lower
Antifrogen L	AntifroL	20 - 60 %	-120 °C ¹⁾	Clariant	P ³⁾	Not harmful to health For pharma-sector, food use
Tyfocor	Tyfocor	20 - 60 %	-120 °C ¹⁾	Tyfocor	E	See type E
Tyfocor-L	TyfocorL	20 - 60 %	-120 °C ¹⁾	Chemie	P	See type P
DowCal 10	DOUCAL10	30 - 70 %	-120 °C ¹⁾	Dow	E	See type E
DowCal 20	DOUCAL20	30 - 70 %	-120 °C ¹⁾	Dow	E	See type E
Glythermin P44	GLYTHP44	40 - 80 %	-100 °C ¹⁾	BASF	P	FDA-approved in USA, corrosion protection less effective For pharma-sector and food-production plants
Temper -10	TEMPER10	100 % fixed	-10...150 °C	Temper	S	Ready-to-use saline solution
Temper -20	TEMPER20	100 % fixed	-20...150 °C	Temper	S	Not harmful to health, (also for pharma and food sectors) Biodegradable, water-protection class 1
Temper -30	TEMPER30	100 % fixed	-30...150 °C	Temper	S	Low viscosity
Temper -40	TEMPER40	100 % fixed	-40...150 °C	Temper	S	High heat-transfer capacity

- 1) Minimum temperature depends on concentration -40...0 °C
- 2) Ethylene glycol-based
- 3) Propylene glycol-based
- 4) The above designations are the registered trademarks of their respective manufacturers.

The following graphs give an example of how the dependency of temperature on specific heat and density can have an important bearing on the final calculation.

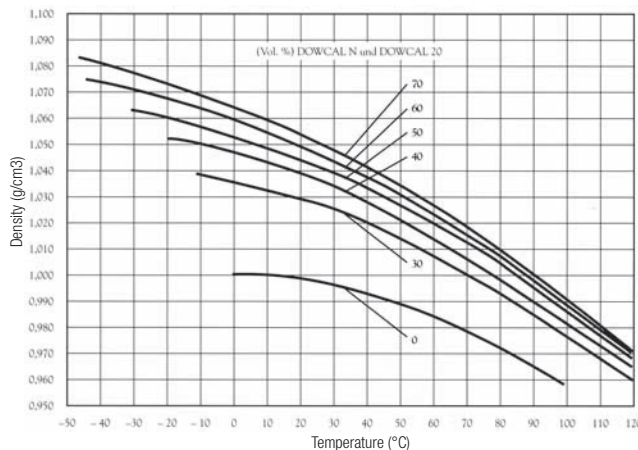

DOWCAL is a registered trademark of the Dow Chemical Company

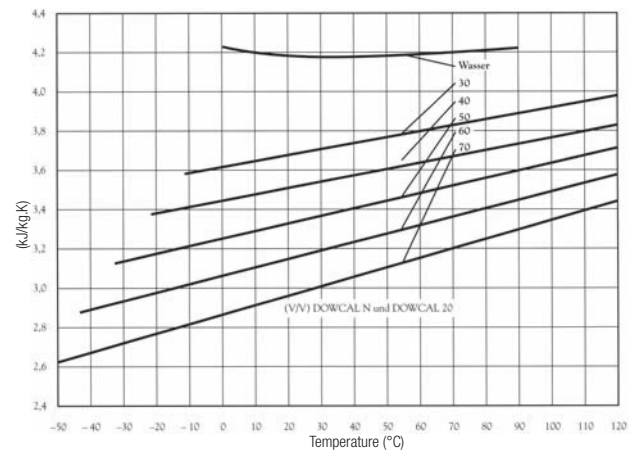

Solar-powered thermal systems

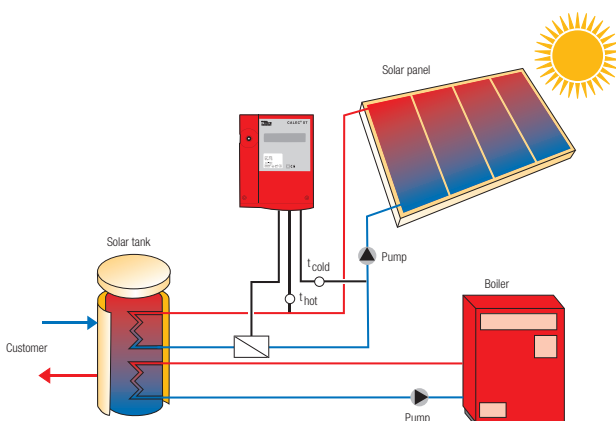

Solar thermal systems likewise pose demanding tasks for energy metering with respect to temperature range and heat transfer medium.

The “**Glycol-based heat transfer medium**” (GLY) option available with CALEC® ST also offers an excellent solution in these cases (further details in the section on refrigeration systems).

CALEC® ST Flow

The CALEC® ST Flow configuration is designed for flow-rate measurement purposes. Temperature measurement (“hot” and “cold” side) is disabled in this configuration, i.e. no temperatures are detected or displayed. CALEC® ST Flow uses the accumulated pulse signals from the flow detector to calculate the current flow-rate reading. These measurement readings can be sent to the display, the analogue outputs and/or the M-Bus or LON interface for reading or further processing.

CALEC® ST configurations

Available CALEC® ST configuration variants in accordance with our country-specific price lists.

Operation

Thanks to their logically-structured functioning, all setting adjustments on the CALEC® ST can be carried out locally and without the use of additional equipment.

Multi-function display

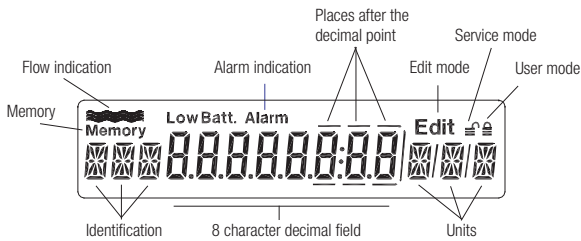

The multi-function display shows the eight-digit meter reading, along with symbols and short texts for user operation purposes.



The displays can be selected using two buttons during operation or when the housing is closed:

Operating buttons



Under the cover, and thus protected by the lead seal, is the Service button, which allows additional service information to be displayed and adjustments to be carried out.

Service button

Professional installers have the PC software CALEC® Win K at their disposal (available for download from our website), which provides effective support for initial start-up, data analysis and order specifications.

The following graph shows the information available at various points on the main operating flowchart, along with the short text designations of various sub-functions:

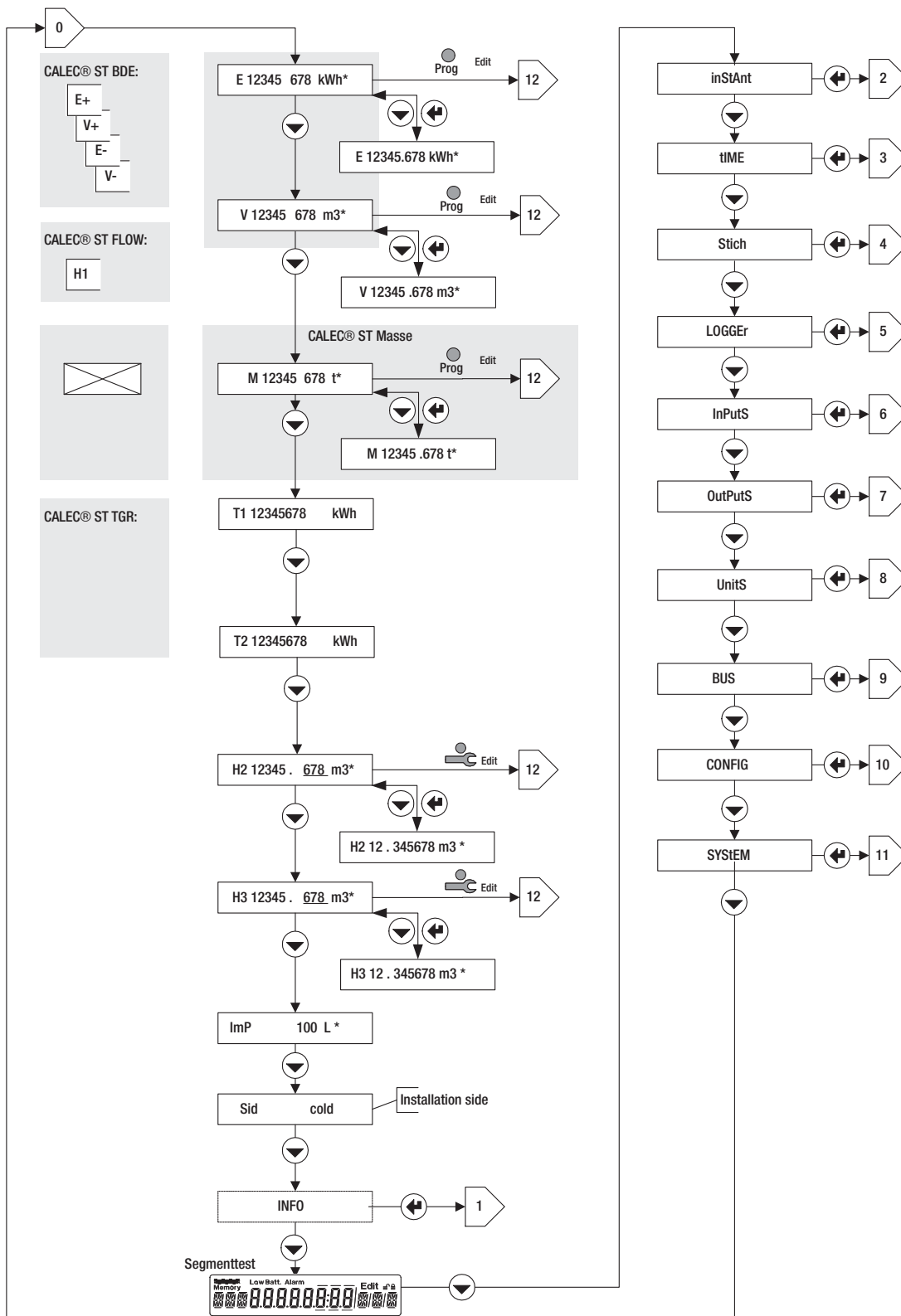

Display:	Description:
Info:	Error message display
InstAnt:	Current readings for temperature, output, flow rate, C-factor, density
Time:	Date and time
Stich:	Critical-date values
LoGGer:	Data-log memory settings
InPutS:	Settings and status of signal inputs
OutPutS:	Settings and status of signal outputs
UnitS:	Measurement-unit settings
BUS:	M-Bus settings
CONFIG:	Further settings (e.g. for glycol-based heat transfer medium)
SYStem:	System data (e.g. firmware version)

Plug-in calculator module

The energy calculator is housed in a plug-in module. The bottom of the housing (which contains the field wiring) does not have to be removed when recalibrating the unit. Furthermore, device-specific data are retained in the configuration memory (EEPROM) in the bottom of the housing (except parameters that are subject to calibration, like impulse value and installation side).

Housing, dimensions

Housing

Lower section with connection terminals, computer module and cover

Installation

DIN-standard rail or three-point attachment directly to the wall

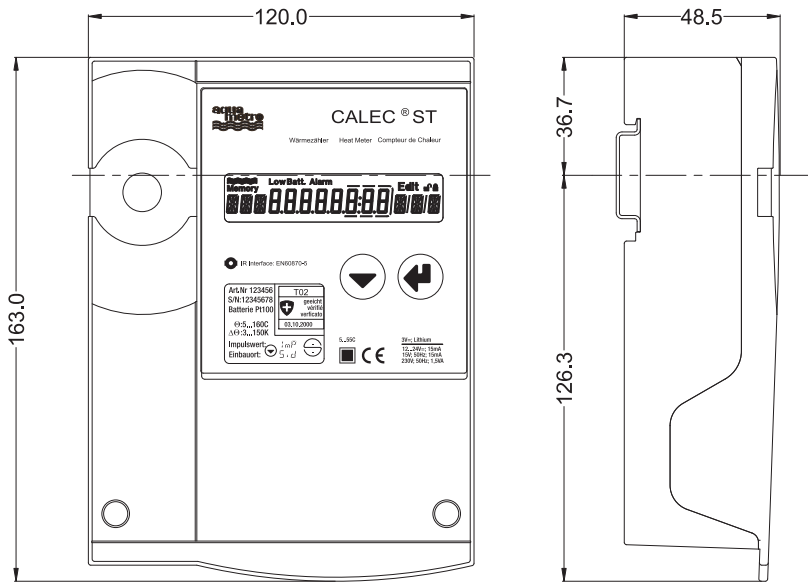

Electrical connections

The wiring layout used depends on device configuration and applicable options. The factory-configured state of the unit is shown on the diagram attached to the inside of the housing cover.

Battery-powered version (Example)

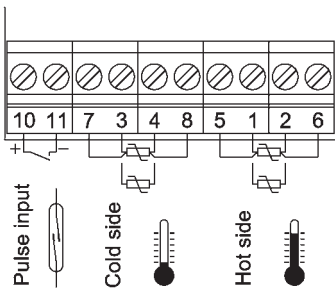

Mains-powered version (with M-Bus and low-voltage supply) (Example)

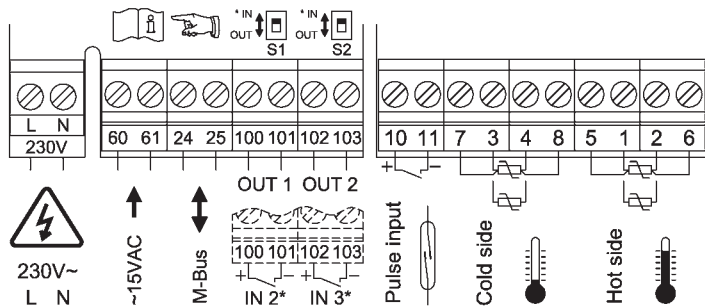

Approval permits

European approval according to the Measurement Instruments Directive (MID) 2004/22/EG, CH-MI004-07001-00
 Pattern approval 22.75/08.02 as cooling meter according to PTB K7.2

Technical data and standards

The following tables contain information on standards and technical data on the available functions. For possible combinations of functions refer to the price list.

Housing and operating conditions	
Dimensions	B x H x T = 120 x 163 x 49 mm
Ambient temperature	+5...+55 °C, EN 1434 class C
Storage temperature	0...60 °C
Optical interface	IEC 870-5, M-Bus protocol

Measurement	
Temperature-measurement range	0...+183 °C, Type approval 5 °C ... 180 °C optional 2...180 °C
Temperature difference	0...175 K, Type approval 3 K ... 175 K optional 2...178 K
Temperature sensor	Pt 100 or Pt 500 paired as per IEC751, with 2- or 4-wire connection
Installation side	"Hot" or "cold"
Pulse value of flow sensor	0.001 to 9999.999 liter
Pulse values and units for auxiliary inputs and contact outputs	Volume: 0.001 to 9999.999 ml, l, m ³ , USGal Energy: 0.001 to 9999.999 kWh, MWh, kJ, GJ, kBtu, MBtu
Error limits	Better than those required for counter mechanisms conforming to EN 1434-1 Suitable for combined class-2 heat metering as per EN 1434-1 when used with suitable volume-metering elements

Display	
Display units, volume	m ³ , USGal
Display units, energy	kWh, MWh, MJ, GJ, kBtu, MBtu
Data backup in event of power failure	In EERPOM >10 years
Data memory	60 data records, tracing 1 x per month, every 2 days, daily (also hourly in mains-powered version)

Additional functions	
Adjustable temperature difference cutoff (SMU)	Function to suppress energy calculation if the temperature differential is too little, ΔT SMU adjustable 0 to 2.99 K
Limit-value monitoring	Single- or two-sided, hysteresis 0 - 10

Battery-powered version	
Power supply	3 V lithium battery, service life >6 years at ambient temperature of <45 °C
Counter cycle	20 s
Main pulse input	High-resistance for contact or transistor output Impulse ≥ 8 ms, pause ≥ 80 ms, max. 10 Hz With symmetrical impulse signal, max. 6 Hz

Mains version	
Power supply	230 VAC ± 10 % 50/60 Hz, <0,5 VA, 12 ... 24 VDC or 15 VAC
Calculating cycle	1 s
Backup battery	3 V Li button cell, 48 mAh
Main pulse input	For NAMUR, contact or transistor pulse transmitters NAMUR: 8V / 1 kOhm, switching points: 1.5 mA, 2.1 mA Pulse width ≥ 0.35 ms, pause >2.5 ms, max. 200 Hz

Options for battery and mains versions	
Pulse input / output and relay outputs	
Inputs / outputs	2 pulse inputs/outputs, selectable with switches
Pulse inputs	For connecting to a pulse transmitter with potential free contact or "open-collector" Pulse width: ≥ 8 ms pause: ≥ 80 ms Frequency: ≤ 10 Hz (symmetric pulses < 6 Hz)
Relay outputs	Max. 48 V / 100 mA (AC/DC), RON: < 20 Ohm, ROFF: > 10 M Ohm The relay outputs are galvanically isolated from themselves and from the calculating unit. Max. potential difference relay contact to device ground: 48 VDC
M-Bus interface	
M-Bus interface	According to EN 13757-2/-3
Baud rate	300, 2400 Baud
Number of interfaces	Two M-Bus interfaces can be used for communication with 2 M-Bus masters
Relay output	Max. 48 V / 100 mA (AC/DC) RON: < 20 Ω ROFF: > 10 M Ω The relay outputs are electrically isolated from each other and from the counter mechanism. Max. potential difference between relay contact and device earth (ground): 48 VDC
LON interface	
Type	FTT-10A, free topology (two wire, twisted pair cable), certified to LONMARK [®] 3.4
Interface power supply	230 VAC ± 10 % 50/60 Hz, $< 0,5$ VA or 12...42 VDC ± 10 % or 12...24 VAC ± 30 % 50/60 Hz
Baud rate	78 kBaud
Max. bus cable length	500 m / 2700 m without / with terminating resistors, 64 nodes per segment

Options for the battery version only	
2 pulse outputs	
2 transistor outputs	max. 48 VDC 50 mA

Options for the mains supply version only	
2 analogue outputs	
Output signal	4...20 mA or 0...20 mA
Power supply	External, 6...24 VDC (passive analogue signals)
Resolution	12 bit
Max. converter error	± 0.15 % full scale plus ± 0.15 % of measured value
Second M-Bus card	Additional M-Bus interface (only with mains supply and analogue output cards)

Low voltage power supply for flow sensor	
Power supply	24 VDC, max. 150 mA
Flow sensor	e. g. AMFLO [®] MAG Smart

Modbus RTU interface	
Physical layer	RS 485
Baud rate	300, 2400, 9600, 19200, 38400
Address range (slave)	1...247
Function code	03: Read holding register
Website	www.modbus.org

N2Open	
Physical layer	RS 485
Baud rate	9600

DISTRIBUTOR:
Micronics Limited



www.bellflowsystems.co.uk



www.aquametro.com