



Delta-Sj-Sdc

**Irrigation impeller
water meter - dry dial**

This model is available in the following versions:

- ***Delta P*** (Standard) *clockwork and head both in plastic*
- ***Delta C*** *“Copper Can” clockwork and plastic head*
- ***Delta P+M*** *plastic clockwork and metal head*
- ***Delta C+M*** *“Copper Can” clockwork and metal head*

Irrigation impellar water meter - dry dial

The DELTA-SJ-SDC can work at high flowrates whilst causing a negligible degree of head-loss.
 The dial plate mechanism and the mechanical totalizer are located in a sealed, vacuum filled housing.
 The DELTA-SJ-SDC is pre-equipped for the connection of a pulse emitter (reed switch type.) It's magnetically coupled dial transmission is protected against external magnetic fields by a special iron shield for security reasons.
 Easy maintenance is assured by the interchangeable metering mechanism, which can be removed whilst in situ.
 This meter can be installed in horizontal or vertical pipes.

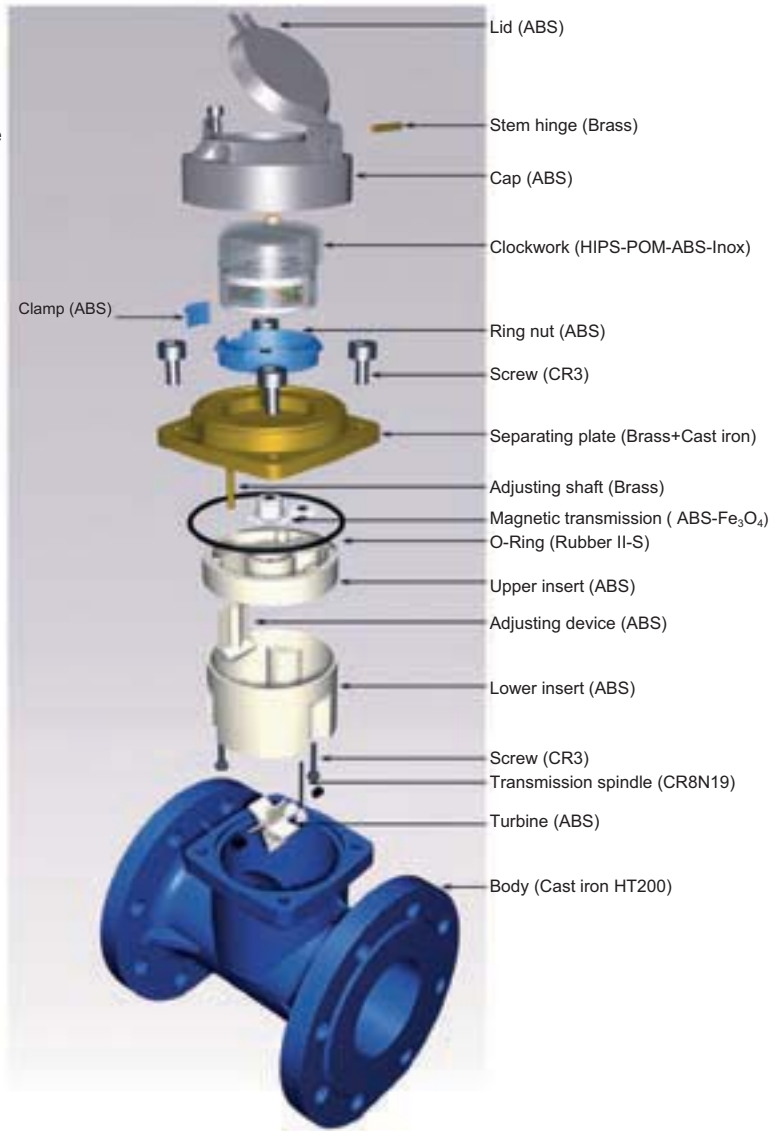
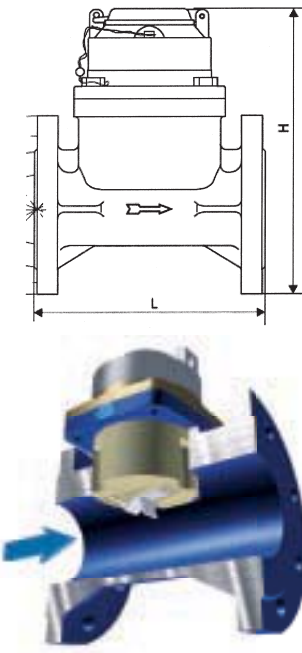

TECHNICAL DATA AND DIMENSIONS

	mm	50	65	80	100	125	150	200	250	300
GAUGE	inches	2"	2.1/2"	3"	4"	5"	6"	8"	10"	12"
Qmax	m ³ /h	70	100	150	250	350	500	900	1200	1600
Qn	m ³ /h	35	50	75	125	175	250	450	600	800
Qt	m ³ /h	10,5	15	22,5	37,5	52,5	75	135	180	240
Qmin	m ³ /h	2,8	4	6	10	14	20	36	48	64
PN	bar	16	16	16	16	16	16	16	16	16
Pressure drop (at Qmax)	bar	<0,1	<0,1	<0,1	<0,1	<0,1	<0,1	<0,1	<0,1	<0,1
Minimum reading	lt	5	5	5	5	5	5	5	50	50
Maximum reading	m ³	10 ⁷	10 ⁷	10 ⁷	10 ⁷	10 ⁷	10 ⁷	10 ⁷	10 ⁸	10 ⁸
Weight	Kg	10,50	12,00	13,00	17,50	21,50	33,00	47,00	70,00	85,00
L	mm	200	200	225	250	250	300	360	450	510
H	mm	160	175	196	215	245	280	330	395	450

