

# The SATURN HD wheel

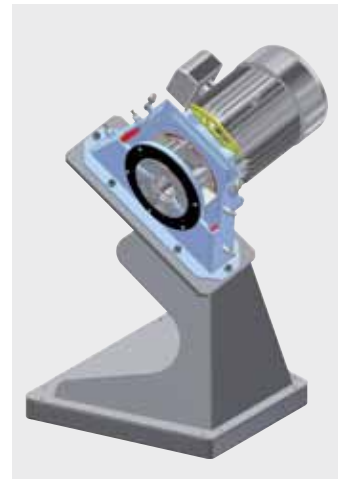

Founded on over 100 years of experience, the SATURN HD blast wheel for the Foundry & Forge industry will improve productivity whilst reducing cycle time.

Designed utilising the latest technology to provide for ease of maintenance and high performance under the toughest conditions, the SATURN HD wheel is available in a wide range of sizes and power to:

- Significantly increase blast equipment productivity
- Provide reduction in cycle times
- Reduce running costs due to long life parts
- Lessen maintenance downtime
- Lower maintenance costs as assembly times are reduced
- Speed up the process of changing wear parts
- Adapt to your changing needs over time
- Fit onto current blasting cabinets without the need for major modifications
- Integrate TargetLok which ensures blast pattern repeatability
- Have the ability to flow abrasive up to S 780 in size
- Provide a tailor-made solution for your needs by defining the abrasive size, flow and shot pattern
- Offer a variable abrasive velocity through easy blade length change
- Operate at reduced noise levels with less vibration as a result of fully machined components

For more information please contact:

**Wheelabrator Group Ltd**  
41 Craven Road, Broadheath, Altrincham WA14 5HJ  
T: +44 1619286388 • F: +44 1619290381  
E: uk-info@wheelabratorgroup.co.uk



---

# The SATURN HD wheel

---



## Different housing versions to adapt to your specific needs

The SATURN HD wheel is available in two high wear resistant versions:

1. Full cast heavy duty manganese housing
  - This is suitable for normal heavy duty applications using steel ball abrasive
  - The cast housing unit uses less component parts, reducing the number of spare parts required
2. Fabricated heavy duty manganese housing with full cast chrome liner
  - This liner package is suitable for hard grit applications

## Direct drive motor

Both the fabricated and cast housing SATURN HD wheel units have been designed utilising a direct coupled motor, this gives additional benefits:

- Increases drive motor efficiencies
  - Maximises energy usage
  - Increases abrasive flow rate
  - Space requirement reduced by half compared to conventional blast wheel units
-

## The SATURN HD wheel

### Retrofitted to all brands of surface preparation equipment

The SATURN HD wheel can easily be retrofitted on all brands of machines in addition to original Wheelabrator equipment such as:

- Tumbblast Equipment
- Roller Conveyors
- Hanger Type Machines
- Table Machines
- Horizontal Belt Machines

### Contact us

To discuss how to have the SATURN HD wheel fitted onto your blast equipment, please speak to a member of your local Wheelabrator Plus team.

Visit [www.wheelabratorgroup.com/contact](http://www.wheelabratorgroup.com/contact)

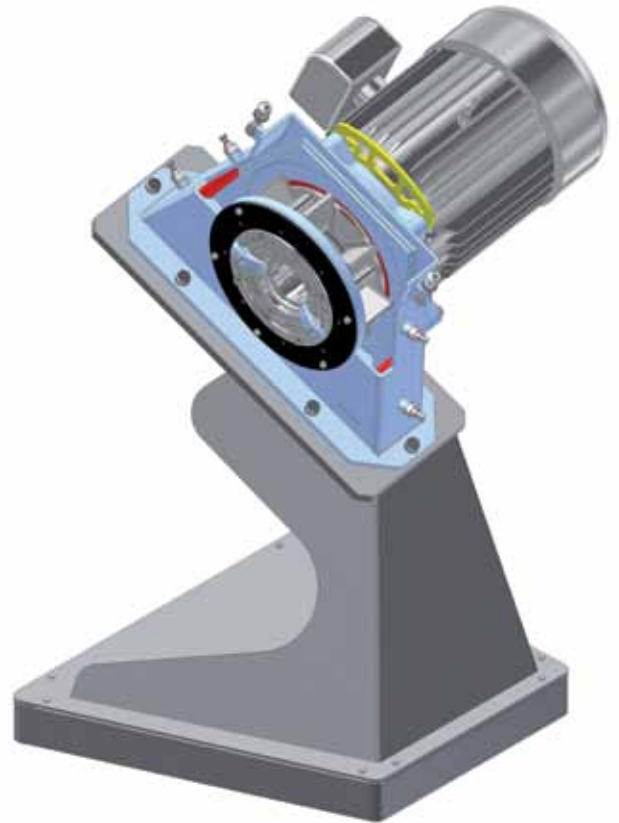

## Technical specifications

Drive power range 15 – 55kw

SATURN HD Size	Diameter (mm)	Abrasive Velocity (m/sec)
140	360	72
160	410	83
180	460	93

---

# About Wheelabrator & Wheelabrator Plus

---

As the world's leading surface preparation company, Wheelabrator offers a complete range of equipment, replacement parts, maintenance packages and sub contract services. With over 15,000 active customers in nearly 100 countries and an estimated 50,000 machines in the field, Wheelabrator continues to use the experience of having the largest installed base in the industry to deliver the best solution for our customers.

With five global technology centres and insight gained from thousands of different applications across an extensive variety of industries, Wheelabrator's technical experts are continually able to develop the best solutions for our customers.

Wheelabrator Plus offers the largest aftermarket parts, supply, service and technical support for the surface preparation industry globally. Offering a one stop shop approach with a wide variety of solutions for our customers, from equipment inspections and upgrades to subcontracting vibratory finishing and shot peening projects, all with the aim of meeting the needs of our customer.

With the capability of maintaining and upgrading surface preparation equipment from both Wheelabrator and most other brands within the industry, Wheelabrator Plus continually strives to contribute in helping you help to profitably meet or even exceed your customer's requirements.

Wheelabrator Plus offers equipment service and maintenance packages, which can be developed around your specific needs to ensure you have minimum downtime whilst achieving maximum productivity. We strive to deliver the highest quality of both replacement parts and service, in the shortest timeframe at the most competitive prices.