

m - mc

ROTARY VANE COMPRESSORS



**Air Compressors for
OEM applications**

Chi siamo



Ing. **Enea Mattei SpA** is an Italian company that has been producing air compressors since 1919. Over the years, the company has continually evolved and is today one of the world's foremost companies in the compressed air sector and the leader in the production of rotary vane compressors.

Behind the success of Mattei are the choices the company has made in terms of design, production and marketing, driven by the results of its continual and in-depth research and development programmes.

Part of this development programme has been the design and manufacture of air compressor packages specifically for OEM applications.

MATTEI FOR OEM APPLICATIONS

Mattei air ends are ideally suited for all "oem" applications because of the pure smooth rotary vane compression principle. Mattei Rotary vane technology delivers high quality clean air, compact size and low noise level coupled with unrivalled reliability in the most demanding of environments.

Mattei design integration allows the compressor to be powered by any type of power system: electric and hydraulic motors, internal combustion or through take-offs.



Simply different The compressor that makes a difference

Compressed air is a versatile and safe resource. For this reason it is successfully used in many OEM applications. OEM requirements demand a totally reliable compressor delivering high quality air on demand.

PERFORMANCE AND EFFICIENCY

Mattei compressors are rotary sliding vane - ensuring high performance.
Mattei compressors have cast iron vanes - delivering high efficiency.

LOW NOISE LEVEL AND HIGH QUALITY AIR

Mattei compressors are pure rotary motion - maintaining a really low noise level.
Mattei compressors have 3 stages of oil separation - delivering a constant supply of high quality air.

RELIABILITY AND LONG LIFE

Mattei compressors run slowly on a constant film of oil - guaranteeing total reliability.

Mattei compressors has a single turning part (rotor) which runs in bushes - ensuring a long life.

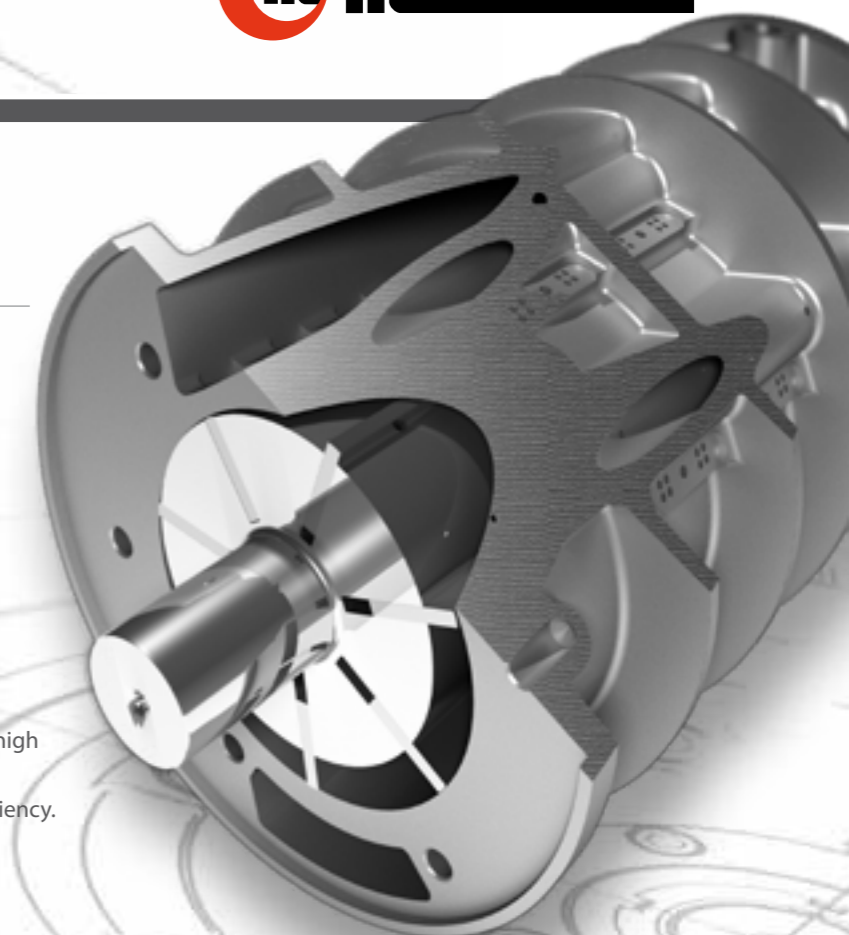

Certified quality

Quality as an integral part of all company functions and constant improvement of all production processes so as to always guarantee the maximum level of reliability and satisfaction. This, in brief, is the value and the meaning of **Mattei's** operational philosophy. A way of approaching the market and customers that makes **Mattei** an absolute point of reference in the compressed air sector.

Since 1994, **Mattei** has been operating with a Quality System certified by the DNV Institute under UNI EN ISO 9001 regulations.



MATTEI M -MC AIR ENDS ARE PERFECT FOR ANY OEM APPLICATION

The compressor can be directly coupled to many types of drive:

- AC electric motors
- DC electric motors
- Hydraulic drives

DIRECT COUPLING 1:1

Mattei rotary vane compressors are directly coupled running at slow speed with no maintenance or parts to replace.

This means minimal energy consumption (solutions available for belt driving).



Operating principle

Maximum efficiency of the air compression process, excellent reliability and low maintenance costs are just some of the key benefits that Mattei rotary vane technology can offer.

The vane compressor is a volumetric rotary compressor that consists of a stator cylinder in which a rotor is mounted off-centre but parallel to its sides. The rotor has slots in which the vanes are free to slide. The vanes are specially profiled so they ride on a cushion of oil which provides lubrication and seals the vanes to the stator during rotation.

Mattei rotary vane compressors are simple in construction offering many advantages to vehicle manufacturers and operators.

Greater volumetric efficiency means more air per revolution.

- » **Cast iron vanes** that bed in during running making the compressor more efficient with time.
- » **No axial forces** means no need for roller or thrust bearings.
- » **Bushes** that will last a lifetime.
- » **Mattei rotary vane compressors** offer total reliability, long life, quiet operation and high quality compressed air.



LOW ROTATION SPEED COMBINED WITH MATTEI ROTARY VANE TECHNOLOGY GUARANTEES

- » compact design
- » maximum efficiency
- » total reliability
- » constant output
- » high quality compressed air
- » low noise
- » continuous run or stop/start
- » no vibration
- » simple maintenance



HIGH EFFICIENCY OIL SEPARATION

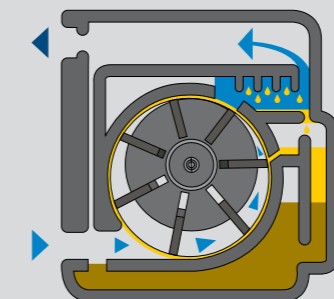

Oil is injected into the air during compression to cool, seal and lubricate. This oil is removed internally before it leaves the compressor.

Separation of oil from air takes place in multiple stages. First separation occurs in the oil chamber as the air passes across a labyrinth, this removes 99.9% of the oil.

At the separator inlet the air flow has directional variations removing even more oil. Finally the air flow passes through coalescing elements removing the final traces of oil to the level of <math><3\text{mg}/\text{m}^3</math>

The inbuilt oil separation system delivers high quality air and extends separator life.

Always caring about our customers' requirements



WORLDWIDE CONSULTANCY AND ASSISTANCE

Mattei operates worldwide with its sales and assistance network, providing a wide service range.

By purchasing a Mattei compressor you can rely on a qualified after-sales service, able to answer any request for assistance in very short time scales.

SIMPLE PREVENTIVE MAINTENANCE

The design of Mattei rotary vane compressors makes maintenance tasks simple, easy and accessible.

Specific maintenance kits make servicing quick and easy maximising operating time.



The range M - MC

Mattei M and MC series are integrated compressors. Oil chamber and oil separator, non-return and minimum pressure valve, regulation valve and oil filter are completely integrated. Moreover, M and MC compressors are equipped with modulationg intake valve for constant air delivery.

MC compressors are supplied complete with integrated oil cooler and flange for motor coupling.

- MC 65, F.A.D. from 120 to 320 litres/min; max. pressure 10 bar.
- MC 80, F.A.D. from 400 to 1100 litres/min; max. pressure 13 bar.
- MC 86, F.A.D. from 800 to 2500 litres/min; max. pressure 13 bar.
- MC 111, F.A.D. from 1800 to 4500 litres/min; max. pressure 13 bar.

- M 80, F.A.D. from 400 to 1500 litres/min; max. pressure 13 bar.
- M 86, F.A.D. from 800 to 3300 litres/min; max. pressure 13 bar.
- M 111, F.A.D. from 1800 to 5600 litres/min; max. pressure 13 bar.
- M 135, F.A.D. from 3000 to 10000 litres/min; max. pressure 13 bar.



Applications

ANY APPLICATION FOR BUILDING INDUSTRY

- Construction industry
- Earthmoving
- Punch
- Sandblasting
- Cave
- Various applications

Mattei original spare parts and lubricants

Mattei Original Spare Parts and Mattei Rotoroil lubricants are made to very high design standards and conform to precise technical specifications. Only Mattei original spare parts allow you to be sure of maintaining over time the same levels of performance, reliability and safety of your Mattei product.

- Mattei Original Spare Parts are indispensable for the efficiency of your compressed air equipment
- Parts are always available in stock
- Quality tested and conforming to manufacturer specifications
- Suitable for Mattei's recommended maintenance intervals





ITALY - ING. ENEA MATTEI SpA

Strada Padana Superiore, 307
20090 VIMODRONE (MI)
Phone + 39 02253051 - Fax +39 0225305243
E-mail: info@mattei.it

www.matteigroup.com

M.T.A. SpA

Mattei Service Partner

C.so Italia, 47
24049 Verdello-Zingonia (BG)
Tel +39 035 4186400 - Fax +39 035 4186490
E-mail: info@mta.bg.it

FRANCE

MATTEI COMPRESSEURS Sarl
Phone +33 535 542 205 - Fax +33 972 316 833
E-MAIL: infos@mattei.fr - www.mattei.fr

GERMANY

MATTEI KOMPRESSOREN DEUTSCHLAND GmbH
Phone +49 7151 5002560 - Fax +49 7151 5002565
E-MAIL: info@mattei-kompressoren.de - www.mattei-kompressoren.de

GREAT BRITAIN

MATTEI COMPRESSORS Ltd
Phone +44 (0)1789 450577 - Fax +44 (0)1789 450698
E-MAIL: info@mattei.co.uk - www.mattei.co.uk

U.S.A.

MATTEI COMPRESSORS Inc
Phone +1 410 5217020 - Fax +1 410 5217024
E-MAIL: info@matteicomp.com - www.matteicomp.com

RUSSIAN FEDERATION

ING. ENEA MATTEI SpA
Phone +7-495-739 41 90 - Fax +7-495-739 41 90
E-MAIL: mattei@inbox.ru

SINGAPORE

ING. ENEA MATTEI SpA
Phone +65 6741 8187 - Fax +65 6741 6826
E-MAIL: mattei@singnet.com.sg

SPAIN

ING. ENEA MATTEI SpA
Phone +34 93 435 03 94 - Fax +34 93 455 26 76
E-MAIL: info@mattei.it

PEOPLE'S REPUBLIC OF CHINA

Zhangjiagang
OMIC AIR COMPRESSORS MANUFACTURING Co. Ltd
WFOE by Ing. Enea Mattei SpA - Italy
Tel: +86 512 56951120 Fax: +86 512 56951121
E-MAIL: info@matteiomc.cn - www.matteiomc.cn

UNI EN ISO 9001:2008