



PRODUCT CATALOGUE

M1-IBA2G13

UNICA

ROTARY VANE COMPRESSORS



UNICA

About Us

Ing. **Enea Mattei SpA** is an Italian company that has been producing air compressors since 1919. Over the years, the company has continually evolved and is today one of the world's foremost companies in the compressed air sector and the leader in the production of rotary vane compressors.

Behind the success of Mattei are the choices the company has made in terms of design, production and marketing, driven by the results of its continual and in-depth research and development programmes.

During these years of continual change, Mattei has been able to adapt to the requirements of the market and through the results of its research has created products that are always innovative and technologically advanced.

Mission

Quality as an integral part of all company functions and constant improvement of all production processes so as to guarantee, always, the maximum level of satisfaction. This, in brief, is the value and the meaning of Mattei's operational philosophy. A way of approaching the market and customers that makes Mattei an absolute point of reference in the compressed air sector.

Since 1994, Mattei has been operating with a Quality System certified by the DNV Institute under UNI EN ISO 9001 regulations.



Rotary Vane Compressors: the Heart of Mattei

Most producers of air compressors use different methods in the compression process, from the rotary vane technology adopted by Mattei.

This is because, although rotary vane technology offers many benefits over other types of air compressor, in order to obtain a high quality, reliable and efficient rotary vane compressor, it is necessary to have specific product experience and knowhow, which is difficult to acquire in a short period of time. Mattei is the undisputed leader in this sector, and has been successfully designing compressors since 1919.

Operating Principle

Maximum efficiency of the air compression process, excellent reliability and low running costs; are just some of the key benefits that rotary vane technology can offer.

The vane compressor is a volumetric rotary compressor that consists of a stator cylinder in which a rotor is mounted off-centre but parallel to its sides. The rotor has slots in which the vanes are free to slide: centrifugal force keeps them in contact with the sides of the stator during rotation.

The rotary vane compressor, thanks to its **simple construction**, offers remarkable advantages, first among them being **greater volume yield** because the vanes are in constant contact with the inner wall of the stator and form a

perfectly airtight seal with no leaks along the wall thanks to a continuous film of oil. In this type of compressor no axial thrust is generated so the side surfaces of the rotor are not subject to wear and thus no rotating bearings or thrust bearings are needed. The vanes, too, because of the special way they are made have practically **unlimited life**.

Behind the success of Mattei compressors there is thus **extreme reliability, long life, quiet operation and simplicity of maintenance**. Design is important too: compactness and clean lines, together with harmonious shapes, give Mattei compressors an image of robustness and ease of use.

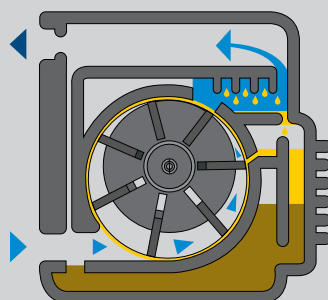
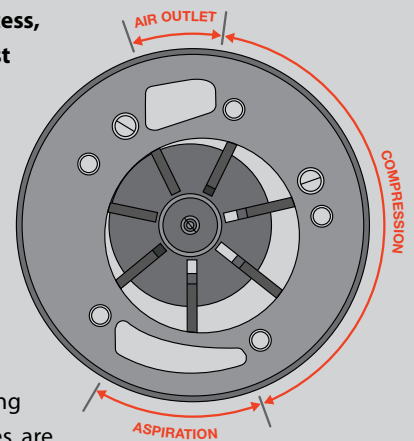

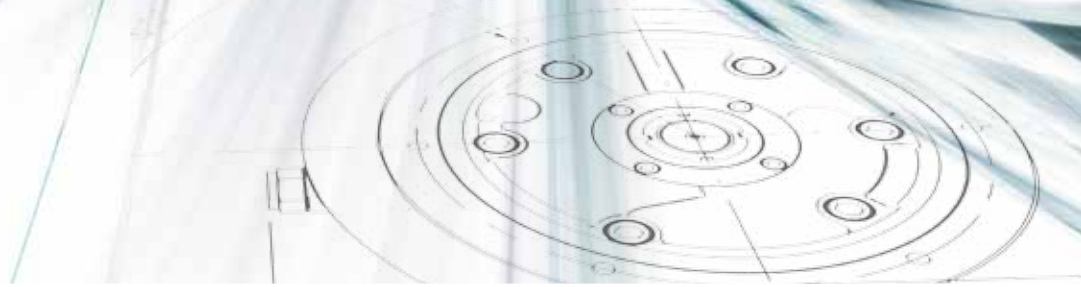

Innovation and Savings

Compressed air is widely used in many industrial sectors. It is safe and versatile, and suitable for most production processes. However, compressed air may represent as much as 10% of production costs. For this reason, companies that produce compressed air efficiently and use it in a rational way can considerably reduce their running costs, saving energy and hence money.

It is important to have a precise idea of one's compressed air requirements and to seek from among the various alternatives the one that ensures maximum efficiency and the lowest energy

consumption. Mattei compressors are designed to optimise energy efficiency and guarantee maximum performance at the lowest possible cost.

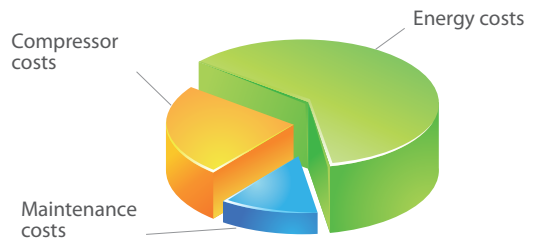

How to Choose the Optimal Compressor



Choosing the right size of compressor is simple but fundamental for avoiding needless energy consumption and possible malfunctioning of the system. Choosing a Mattei compressor is even easier. The first step is to find exactly how much compressed air the systems consumes (**N**) in l/min.

$$N = \frac{(V_1 + V_2) \times \Delta p}{t} \times 60$$

- V₁**= Capacity of the distribution network in litres
- V₂**= Capacity of the receiver in litres
- Δp**= max/min pressure differential (a minimum of 2 bar is recommended).
- T**= time in seconds from maximum to minimum pressure.

To obtain the capacity of the compressor required (**Q**) in l/min just multiply the value of N calculated earlier by a margin coefficient K= 1,20:

$$Q = N \times K$$



Applications



UNICA series rotary vane compressors, with installed powers from 1.5 to 3 kW and flow rates from 160 to 320 l/min, are easy to handle, robust and versatile.

Designed specifically for small and medium companies and craftsmen, UNICA compressors are ideal for those who want to limit investment and running costs but do not want to compromise on the quality and reliability their compressed air supply and the product supplying it.



UNICA compressors are suitable for several applications, for example:

- Tyre centres
- Painters
- Car washes
- Carpenters
- Bricklayers
- Petrol stations
- Garages
- Mechanics
- Body shops
- Laundries
- Supermarkets
- Bakers
- Laboratories



UNICA



Service

Mattei is present with its sales and service network in more than 40 countries in Europe, America, Africa, the Middle East, Asia and Oceania.

When you purchase a Mattei compressor you enjoy highly qualified after sales service all over the world that can respond very quickly to any request for help. Technicians and engineers are at your complete disposal for advice, plant analysis, operational safety evaluation and to identify possible savings.

Original Spare Parts

Mattei Original Spare Parts are made to very high design standards and conform to precise technical specifications. Only Mattei original spare parts allow you to be sure of maintaining over time the same levels of performance, reliability and safety of your Mattei product.

- **Mattei Original Spare Parts are indispensable for the efficiency of your plant**
- **Parts are always available in stock**
- **Quality tested and conforming to manufacturer specifications**
- **Suitable for Mattei's recommended maintenance intervals**

ROTOROIL 8000 F2 SYNTHETIC OIL

The use of original Rotoroil 8000 F2 lubricant, specially formulated for Mattei rotary compressors, ensures longer intervals between maintenance operations and also optimal performance.



THE UNICA SERIES

As in large industrial plants, small and medium sized ones also require clean compressed air, that is free of condensation, oil and dust. This is because the machines that use this resource are increasingly sophisticated and sensitive to any impurities contained in the air. The craftsman or small business today needs high quality compressed air, but with a further requirement: reduced running costs with compressors that are

reliable, long lasting and cost little to maintain. The choice of a UNICA series rotary vane compressor is thus a must for any application that needs to optimise the use of compressed air.



The Range

With their technologically innovative design, UNICA series compressors are a guarantee of quality, efficiency and reliability. Models are available with power from 1.5 to 3 kW, on bases or on 90 and 200 litre receivers. All UNICA series compressors have a pressure switch for Start-Stop operation.

Safety and protection

UNICA series compressors fully conform to all safety and protection regulations.

All compressors have:

- an auxiliary low tension electrical circuit for complete safety
- a thermostat that automatically switches off the motor if the air-oil mixture inside the compressor overheats
- A safety pressure exhaust valve that automatically discharges surplus compressed air into the atmosphere if pressure gets too high
- Thermal protection that automatically stops the motor if too much current is absorbed.



Unica



Unica S 90 Litres



Unica S 200 Litres

Innovations and Advantages

A SINGLE SHAFT FOR MOTOR AND COMPRESSOR

Power is transmitted directly to the compressor rotor by an elongated motor shaft, thus permitting:

- Maximum yield
- Low maintenance costs

INTEGRATED COOLING

The heat generated by compression is dispersed by a flow of cooling air from the fan attached to the electric motor which is blown across the special fins on the oil chamber. This solution avoids the problems and risks of blockage and subsequent overheating if a cooling radiator is not kept clean and therefore does not work correctly.

QUALITY COMPRESSED AIR

Special three-stage air-oil separation permits superior quality air to be obtained with very low oil carry over.

ANTI-CONDENSATE VALVE

Mattei has patented a unique and innovative anti-condensation system that, in conditions of low usage, prevents humidity in the air from condensing in the oil.

The special anti-condensate valve ensures that the optimal working temperature is reached so as to guarantee constant functioning over time.

EASE OF MAINTENANCE

The UNICA series requires very little maintenance.

To facilitate the few operations required, UNICA compressors are supplied with a single, comprehensive maintenance kit.

EASY TO INSTALL

UNICA series compressors do not need foundations or fixing. They can simply be placed on a flat surface. They are supplied complete with power cable and plug.



Symbols Explained



Receiver



Motor



Noise level



Air delivery



Tension



Maximum pressure



Dimensions



Weight



Air intake volume of an equivalent piston compressor



Rotational speed



Rotary vane compressor



Made in Italy

UNICA



The UNICA model requires a receiver to be connected, of a minimum 90 litres for the UNICA 1 and UNICA 2 models and a minimum of 200 litres for the UNICA 3 model.

UNICA	Model	Volt/H/Ph	r.p.m.	L	Power		Flow			Capacity		Pressure		dB(A)	LxWxH (mm)	kg
					kW	hp	l/min	m ³ /h	cfm	l/min	cfm	bar	psig			
230/1																
UNICA 1	GEXAC4XA0C	230/50/1	1500	-	1,5	2	160	9,6	5,65	250	8,83	10	150	64	580x390x440	41
UNICA 1 S-90	GEJAC4XABC	230/50/1	1500	90	1,5	2	160	9,6	5,65	250	8,83	10	150	64	1000x460x910	74
UNICA 1 S-200	GEJAC4XA0C	230/50/1	1500	200	1,5	2	160	9,6	5,65	250	8,83	10	150	64	1050x600x1120	113
UNICA 2	GEXAB4XA0D	230/50/1	1500	-	2,2	3	240	14,4	8,48	360	12,71	10	150	64	580x390x440	43
UNICA 2 S-90	GEJAB4XABD	230/50/1	1500	90	2,2	3	240	14,4	8,48	360	12,71	10	150	64	1000x460x910	76
UNICA 2 S-200	GEJAB4XA0D	230/50/1	1500	200	2,2	3	240	14,4	8,48	360	12,71	10	150	64	1050x600x1120	115
400/3																
UNICA 1	GEXAC4XB0C	400/50/3	1500	-	1,5	2	160	9,6	5,65	250	8,83	10	150	64	580x390x440	40
UNICA 1 S-90	GEJAC4XBBC	400/50/3	1500	90	1,5	2	160	9,6	5,65	250	8,83	10	150	64	1000x460x910	73
UNICA 1 S-200	GEJAC4XB0C	400/50/3	1500	200	1,5	2	160	9,6	5,65	250	8,83	10	150	64	1050x600x1120	112
UNICA 2	GEXAB4XB0D	400/50/3	1500	-	2,2	3	240	14,4	8,48	360	12,71	10	150	64	580x390x440	42
UNICA 2 S-90	GEJAB4XBBD	400/50/3	1500	90	2,2	3	240	14,4	8,48	360	12,71	10	150	64	1000x460x910	75
UNICA 2 S-200	GEJAB4XB0D	400/50/3	1500	200	2,2	3	240	14,4	8,48	360	12,71	10	150	64	1050x600x1120	114
UNICA 3	GEXAC4XBAC	400/50/3	3000	-	3	4	320	19,2	11,3	450	15,89	10	150	70	580x390x440	43
UNICA 3 S-200	GEJAC4XBCC	400/50/3	3000	200	3	4	320	19,2	11,3	450	15,89	10	150	70	1050x600x1120	115





ITALY - ING. ENEA MATTEI SpA

Strada Padana Superiore, 307
20090 VIMODRONE (MI)
Tel + 39 02253051 - Fax +39 0225305243
E-mail: info@mattei.it

M.T.A. SpA

Mattei Service Partner

C.so Italia, 47
24049 Verdello-Zingonia (BG)
Tel +39 035 4186400 - Fax +39 035 4186490
E-mail: info@mta.bg.it

www.matteigroup.com

FRANCE

MATTEI COMPRESSEURS Sarl
Phone +33 535 542205 - Fax +33 972 316833
E-MAIL: infos@mattei.fr

GERMANY

MATTEI KOMPRESSOREN DEUTSCHLAND GmbH
Phone +49 7151 5002560 - Fax +49 7151 5002565
E-MAIL: info@mattei-kompressoren.de

GREAT BRITAIN

MATTEI COMPRESSORS Ltd
Phone +44 (0)1789 450577 - Fax +44 (0)1789 450698
E-MAIL: info@mattei.co.uk

U.S.A.

MATTEI COMPRESSORS Inc
Phone +1 410 5217020 - Fax +1 410 5217024
E-MAIL: info@matteicomp.com

RUSSIAN FEDERATION

ING. ENEA MATTEI SpA
Phone +7-495-739 41 90 - Fax +7-495-739 41 90
E-MAIL: mattei@inbox.ru

SINGAPORE

ING. ENEA MATTEI SpA
Phone +65 6741 8187 - Fax +65 6741 6826
E-MAIL: mattei@singnet.com.sg

SPAIN

ING. ENEA MATTEI SpA
Phone +34 93 435 03 94 - Fax +34 93 455 26 76
E-MAIL: info@mattei.it

PEOPLE'S REPUBLIC OF CHINA

Zhangjiagang
OMIC AIR COMPRESSORS MANUFACTURING Co. Ltd
WFOE by Ing. Enea Mattei SpA - Italy
Tel: +86 512 56951120 Fax: +86 512 56951121
E-MAIL: info@matteiomc.cn