

# Victor

Banquet Series

## BANQUETLINE

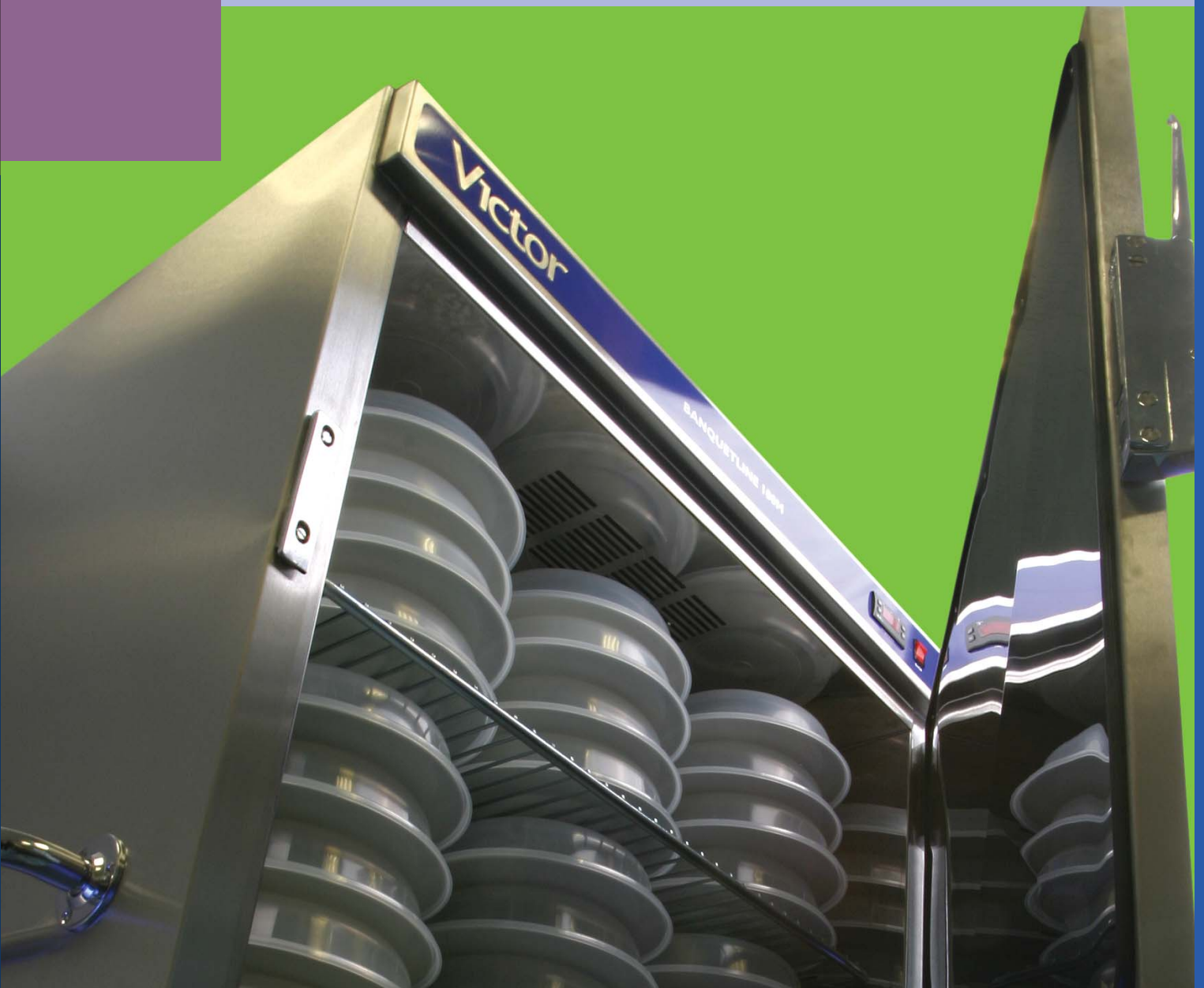

## Banquetline Series

### Application

A hot hold banqueting system to hold hot food in perfect condition, complimentary refrigerated units to hold pre-chilled food.

Banquetline provides the caterer with the opportunity to prepare and plate meals in advance of the required service time.

### Flexibility

Banquetline provides flexibility to systemise large scale catering enabling more efficient staff usage. Plated meals can be held stacked using plate covers or individually on shelves.

Shelves and supports are removable and adjustable to multiple positions. Banquetline is fully gastronorm compatible allowing food to be held in bulk.

### Hygiene

Easily accessed and removable internal components with bright annealed stainless steel interior. Radius internal corners and minimal dirt traps give Banquetline top marks for hygiene.

### Mobility

Robust and rugged, Banquetline enables food to be transported smoothly and safely from the kitchen to dining area. With 150mm castors, all round bumpers and heavy duty push bars.

All units operate from a 13 amp supply powering the fan assisted 1.5kW top mounted heating system.

### Humidity & Control

Cabinet temperature is easily adjustable between 65° and 95°C using the digital microprocessor temperature control.

Optional humidity is provided via the integral water reservoir in the cabinet base. The required temperature settings and humidity will vary according to the type of food held.

The basic rules of holding food are:

- The shorter the time held, the less effect on the sensory quality.
- The lower the temperature, the longer food can be held in perfect condition.
- Food with a high moisture content holds best suitably covered and with increased humidity.

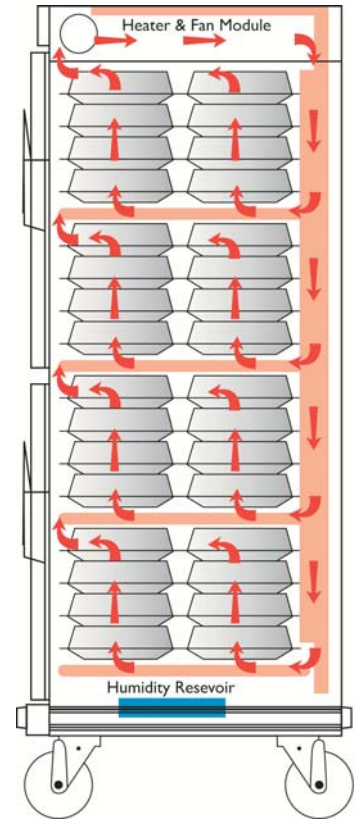

BL200H4

BL50HIS



BL70HI

## Heated Models

**Banquetline 50 slim**

Suited to the smaller operation, hire market, or where a high degree of portability is required. This slimline model has been designed to fit through narrow, 700mm wide doors, found on some lifts.

Holds up to 44 standard 10" plates or 11 GN1/1 x 65mm deep gastronorm containers.

Complete with 4 shelves & supports and one push bar.

**BL50HIS**

755 x 700 x 1240mm

1.5kW

**Banquetline 50**

Suited to the smaller operation, hire market, or where a high degree of portability is required. This model is designed to enable GN1/1 size containers to fit on the shelf brackets eliminating the need for additional shelves.

Holds up to 60 standard 10" plates or 22 GN1/1 x 65mm deep gastronorm containers. Complete with 4 shelves & supports and one push bar.

**BL50HI**

855 x 790 x 1240mm

1.5kW

**BL100H2MAX****Banquetline 70**

Sharing the same footprint as the BL50 model, the BL70 is taller giving it almost 50% more capacity. This model is designed to enable GN1/1 size containers to fit on the shelf brackets eliminating the need for additional shelves.

Holds up to 80 standard 10" plates or 32 GN1/1 x 65mm deep gastronorm containers

Complete with 4 shelves & supports and one push bar.

**BL70HI**

855 x 790 x 1590mm

1.5kW

## Heated Models

**Banquetline 100 - one door**

A highly flexible unit which combines a large capacity with the ability to transport food from kitchen to dining area.

Holds up to 108 standard 10" plates or 22 GN1/1 x 65mm deep gastronorm containers.

Complete with 4 shelves & supports and two push bars.

**BL100H1**

1070 x 760 x 1810mm

1.5kW



150mm heavy duty castors and wrap round bumpers are standard to all units.

**Plate Covers**

Hot meals are best held covered by a suitable plate cover. Victor plate covers, available as an optional extra, are stackable and made from translucent polypropylene. They are virtually unbreakable, dishwasher proof and can be used in temperatures between -20°C and +120°C.



Additional shelves allow for food to be held in Gastronorm containers, available as optional extras, or silver service platters.

**Banquetline 100 - two door**

The same size unit as the BL100H1 except with two doors. This helps to prevent heat loss if the door is opened frequently.

Holds up to 108 standard 10" plates or 22 GN1/1 x 65mm deep gastronorm containers.

Complete with 4 shelves & supports and two push bars.

**BL100H2**

1070 x 760 x 1810mm

1.5kW



### Banquetline 100 Maxi - two door

A larger unit than the BL100 designed to accommodate large plate sizes. This unit will accept six 11" plates per level.

Holds up to 120 standard 10" plates or GN1/1 x 65mm deep gastronorm containers.

Complete with 4 shelves & supports and two push bars.

**BL100H2MAX** 1140 x 780 x 1900mm 1.5kW



The digital temperature controller allows the operator to easily set or adjust the temperature within the cabinet between 65°C and 95°C. Simply press the set button and adjust the display to the required setting. The thermostatic control will then hold cabinet at that temperature.

### Staykold Eutectic Plates



The chilled section of the combination unit uses Victor Staykold eutectic plates. Place the Eutectic plates in a freezer at minus 4°C for at least 12 hours.

Depending upon the operating conditions the plates will function for between 6 and 12 hours.

**Dimensions:** GN1/1 size 530 x 325 x 30mm **Weight:** 4kg

### Banquetline 100 Combination

A two compartment unit, The top heated, the bottom chilled using Victor Staykold Eutectic plates. This allows both hot and chilled food to be held and transported in the same cabinet.

These units feature both the digital temperature controller for the heated section and a separate solar power temperature display for the chilled section.

Complete with 4 shelves & supports and two push bars. Eutectic plates are purchased separately (four required).

**BL100HCF2** 1070 x 760 x 1810mm 1.5kW



## Heated Models



### Banquetline 200

Designed for the larger operation the BL200 comprises two cabinets side by side having independent heating modules. This allows the operator to use either one or two cabinets as the requirement dictates.

Whilst BL200 models feature heavy duty 150mm castors and wrap round bumpers, the size and weight of the units when fully loaded makes them less practical for transporting meals over long distances.

Holds up to 216 standard 10 plates or 44 GN1/1 x 65mm deep gastronorm containers.

Complete with 8 shelves & supports and two push bars.

**BL200H4** 1950 x 760 x 1810mm 3.0kW  
Four door

**BL200H2** 1950 x 760 x 1810mm 3.0kW  
Two door model not illustrated

## Refrigerated Model



### Refrigerated Banquetline

Complementary to the heated range is the refrigerated Banquetline comprising a stainless steel cabinet with integral compressor unit in the base of the unit.

#### Features

- Microprocessor temperature control adjustable between 2°C and 5°C
- Inset push / pull handles
- Wrap round bumpers
- Accepts 2 x GN1/1 containers per shelf
- Supplied with 3 shelves
- Holds up to 56 standard 10" plates or 40 GN1/1 x 40mm deep gastronorm containers.

**BL1REF** 805 x 885 x 1960mm 0.5kW

Dimensions

Banquetline 50 Slim

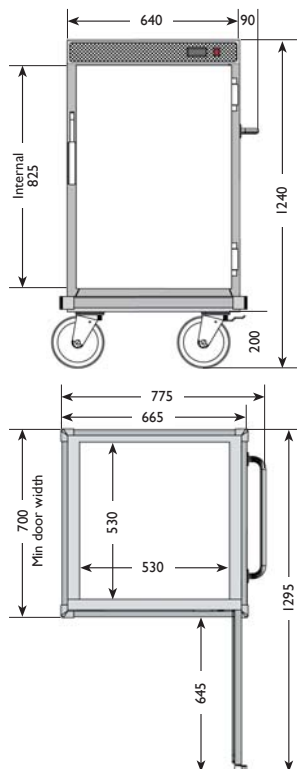

Banquetline 50

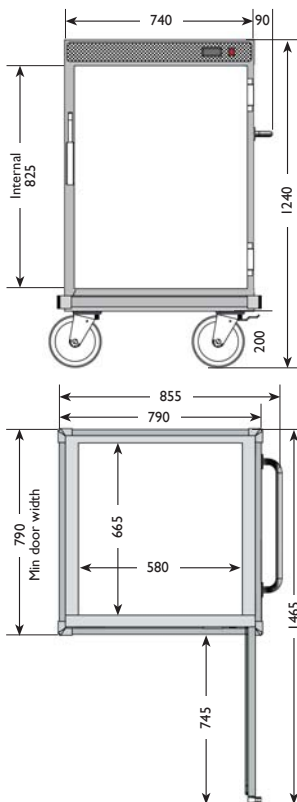

Banquetline 70

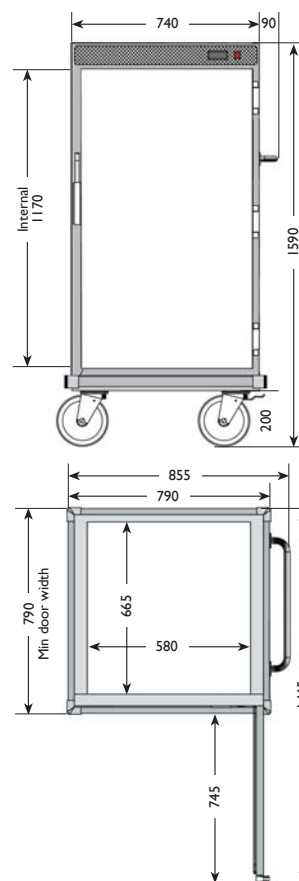

Banquetline 100

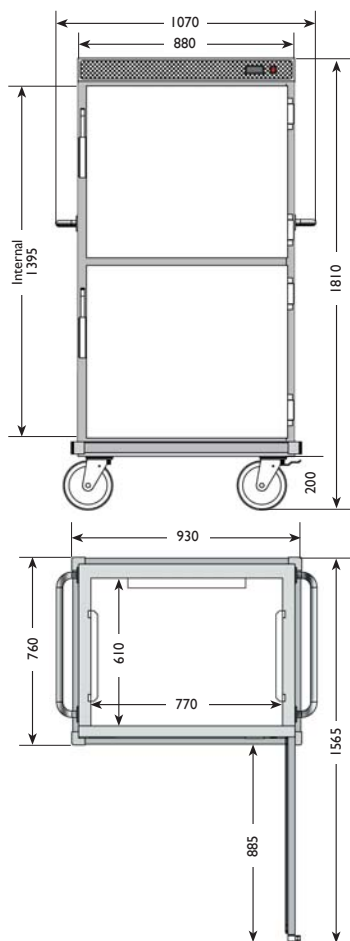

Banquetline 100 Maxi

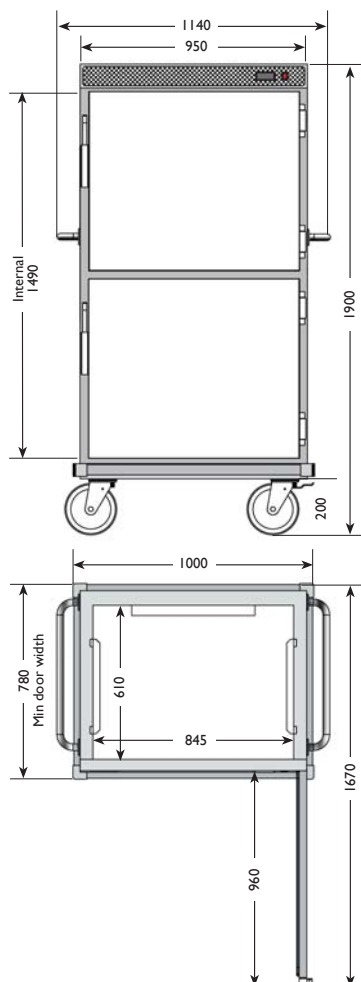

Banquetline 200

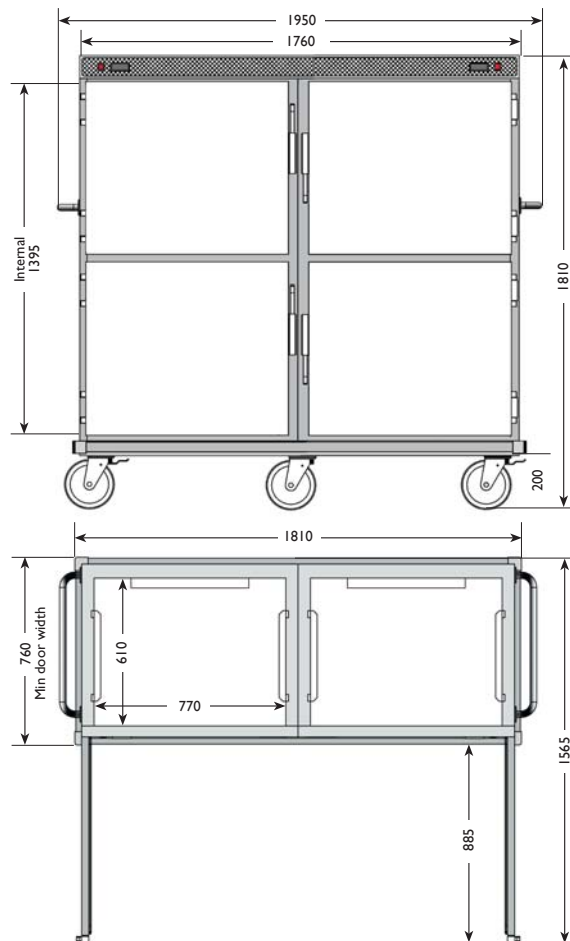

All dimensions in mm.

## Technical Specification

| Code      | Description                     | Length | Width | Height | Max shelf position | Max 10" plates* | Gastronorm Container Capacity |         |         |          |          |          |
|-----------|---------------------------------|--------|-------|--------|--------------------|-----------------|-------------------------------|---------|---------|----------|----------|----------|
|           |                                 |        |       |        |                    |                 | GN 1/20                       | GN 1/40 | GN 1/65 | GN 1/100 | GN 1/150 | GN 1/200 |
|           | <b>Banquetline 50</b>           | 855    | 790   | 1240   |                    |                 |                               |         |         |          |          |          |
| BL50HI    | Heated one door                 |        |       |        | 21                 | 55              | 44                            | 22      | 20      | 10       | 8        | 6        |
|           | <b>Banquetline 50 slim</b>      | 755    | 700   | 1240   |                    |                 |                               |         |         |          |          |          |
| BL50HIS   | Heated one door                 |        |       |        | 11                 | 44              | 11                            | 11      | 10      | 5        | 4        | 3        |
|           | <b>Banquetline 70</b>           | 855    | 790   | 1590   |                    |                 |                               |         |         |          |          |          |
| BL70HI    | Heated one door                 |        |       |        | 32                 | 80              | 64                            | 32      | 32      | 20       | 12       | 10       |
|           | <b>Banquetline 100</b>          | 1070   | 760   | 1810   |                    |                 |                               |         |         |          |          |          |
| BL100HI   | Heated one door                 |        |       |        | 42                 | 108             | 42                            | 42      | 28      | 20       | 16       | 12       |
| BL100H2   | Heated two doors                |        |       |        | 42                 | 108             | 38                            | 38      | 28      | 18       | 12       | 10       |
| BL100HCF2 | Combi- Heated/chill two doors   |        |       |        | 38                 | 96              | 38                            | 38      | 28      | 18       | 12       | 8        |
|           | <b>Banquetline 100 maxi</b>     | 1140   | 780   | 1900   |                    |                 |                               |         |         |          |          |          |
| BL100H2M  | Heated two doors                |        |       |        | 38                 | 120             | 76                            | 38      | 26      | 16       | 14       | 12       |
|           | <b>Banquetline 200</b>          | 1950   | 760   | 1810   |                    |                 |                               |         |         |          |          |          |
| BL200H2   | Heated two doors                |        |       |        | 42                 | 216             | 84                            | 84      | 56      | 40       | 32       | 24       |
| BL200H4   | Heated four doors               |        |       |        | 42                 | 216             | 76                            | 76      | 56      | 36       | 24       | 20       |
|           | <b>Banquetline Refrigerated</b> | 805    | 885   | 1960   |                    |                 |                               |         |         |          |          |          |
| BLREFI    | One door                        |        |       |        | 20                 | 56              | 40                            | 40      | 20      | 14       | 14       | 10       |

\* Capacities are based upon a 10" plate stacked using 60mm plate covers



# Victor

## BANQUETLINE

Victor Manufacturing Limited.

Lonsdale Works

Gibson Street

Bradford BD3 9TF

Tel: 01274 722125

Fax: 01274 307082

[email@victormanufacturing.co.uk](mailto:email@victormanufacturing.co.uk)

[www.victoronline.co.uk](http://www.victoronline.co.uk)



VML031  
10/09