

# Victor

Table Top Displays

## Toppers



# Victor

## Toppers

Established in 1944 Victor Manufacturing Limited has steadily grown to become one of the UK's top catering equipment manufacturers. Over 50 years experience in design, manufacture and continual product development has allowed Victor to produce the best servery equipment available in the market.

Our head office, manufacturing and distribution facilities in Bradford are equipped with modern precision computer aided equipment all operated by a highly skilled workforce. In common with all of our products our progressive product development ensures Victor Toppers meet the ever changing needs of the Catering Industry.

Victor prides itself on a speedy and efficient service. We recognise the importance of product quality and were awarded ISO9002 in 1987 and ISO9001 in 2001. All Victor products are CE marked and meet or exceed current legislation.



### Sorrento Refrigerated Displays

Refrigerated	- Self service	3
Refrigerated	- Back service	3



### Deli Toppers

Heated	- Plain top	4
	- Bains Marie	4
Ambient Units		5
Refrigerated Units		7



### Heated Display Units

Quartz lamp	- Plain top	8
Quartz lamp	- Glass top	8
Chilled Display Unit		9



### Caribbean Toppers

Heated	- Bains Marie	9
	- Glass & Stainless Steel	10
	- Tiled & Carvery	11
Refrigerated	- Contact Cooled	12
	- Ice Cooled	12



### Buffet Toppers

Carvery top		13
Glass top		13
Tiled top		13
Stainless top		13



### Hot Plates

Infrared lamp units		14
Hot plates		14



### Hot Food Merchandising

Burger Chute		14
Hot food unit, Pizza display		15
Pie warmers		15



## Sorrento

A stylish, unobtrusive cabinet which displays your products with maximum impact, whilst keeping them in perfect condition. The position of the compact refrigeration module inside the case allows you to maximise sales from a minimum of counter space. Fluorescent illumination to the top, along with clear acrylic front and sides, provides maximum impact to the products on display. No installation required complete with self evaporating defrost system.

### Product Features

- Blown air refrigeration.
- Microprocessor controlled temperature display.
- Easily maintained, removable modular refrigeration system.
- R404 CFC free refrigerant.
- 304 stainless steel base.
- Removable chromed shelves.
- Removable acrylic windows.
- Wipe clean, reinforced plastic end panels.
- Hinged, lift up serving flaps to self service units
- Curved screen to front, top hinged, can be lifted up for cleaning on back service models
- Sliding rear doors on 100 models, hinged door on 70 models
- Maintains cabinet temperature between 3°C & 5°C in ambient temperatures of up to 32°C.
- Less than 1kW loading.
- Supplied with 13 amp plug.

Ambient models available to special order



### Sorrento 100 - 3 levels

3 level self service - Model No. SOR100F3

3 level back service only - Model No. SOR100B3

1000 x 650 x 700mm



### Sorrento 70

3 level self service - Model No. SOR70F3

3 level back service only - Model No. SOR70B3

2 level self service - Model No. SOR70F2

2 level back service only - Model No. SOR70B2

700 x 650 x 700mm



### Sorrento 100 - 2 levels

2 level self service - Model No. SOR100F2

2 level back service only - Model No. SOR100B2

1000 x 650 x 700mm

### Dimensions

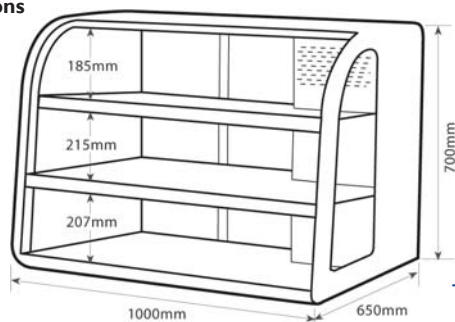

Three level models

Two level models

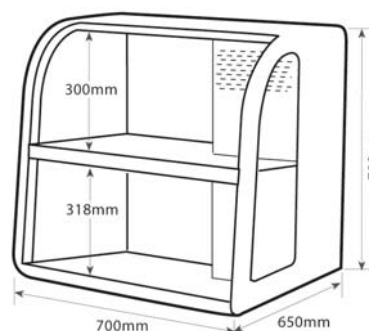

## Deli Toppers

A range of co-ordinated heated, refrigerated and ambient counter top display units designed for food to go application.

### Heated Units - Plain Top

Designed to maintain the temperature of hot food by providing heat from below supplementing heat from above via quartz halogen heat lamps.

- Stainless steel construction.
- Variable heat control to base.
- Removable glass side panels.
- Bright polished gantry arms and light box housing.
- Operator changeable quartz heat lamps.
- Choice of full height curved glass screen or curved glass sneeze screen.
- Three model sizes.
- All units operate from a single 13 amp supply and are supplied with 2 metres of cable and a fused 13 amp plug.



Model No. **MHPL3W**  
1177 x 660 x 620mm



Model No. **MHBM2**  
850 x 660 x 620mm



Model No. **MHPL4**  
1504 x 660 x 620mm

## Special Order Items



Model No. **MHPL3**  
1177 x 660 x 620mm

### Optional Extras

- Removable perforated angled deck panels (as shown).



Deli Topper models can be fitted with a square flat glass gantry to special order.

### Heated Units - Bains Marie Top

A more flexible heated unit is provided with a flat Bains Marie collar which accepts GN1/1 containers up to 100mm deep. With the addition of either glass, tiled or carvery inserts a choice of food presentation options are provided.

- Dry heat well.
- Accepts containers up to 100mm deep (not included)



Model No. **MHBM4**  
1504 x 660 x 620mm



Shown with optional inclined collar

Enhanced presentation of hot food products can be provided by the use of the optional inclined collar

#### Optional Extras

- Inclined collar.
- Tiled inserts.
- Carvery inserts.
- Glass inserts.

### Ambient Units

Designed for attractive display of ambient foods

- Stainless steel construction.
- Fluorescent illumination to top.
- Removable glass side panels.
- Bright polish gantry arms and light box housing.
- Choice of full height curved glass screen or curved glass sneeze screen to the front.
- Choice of one or two shelf models.
- Three model sizes, open front models also available.
- All units operate from a single 13 amp supply and are supplied with 2 metres of cable and a fused 13 amp plug.



Model No. **MAGL3**  
1177 x 660 x 620mm



Model No. **MAGH3**  
1177 x 660 x 780mm



Model No. **MAGL2**  
850 x 660 x 620mm



**Heated Displays - One Tier**  
Full height glass screen and side cheeks.

Part No.	Length	Loading
<b>MHPL2</b>	850mm	1.1kW
<b>MHPL3</b>	1177mm	1.9kW
<b>MHPL4</b>	1504mm	2.7kW



**Heated Displays - One Tier**  
Curved glass sneeze screen and side cheeks.

Part No.	Length	Loading
<b>MHPL2W</b>	850mm	1.1kW
<b>MHPL3W</b>	1177mm	1.9kW
<b>MHPL4W</b>	1504mm	2.7kW

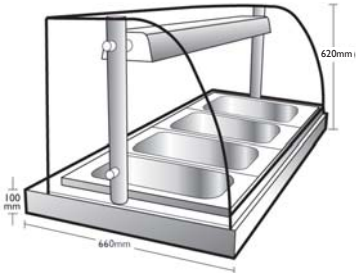

**Heated Displays - Bains Marie**  
Full height glass screen with side cheeks and flat GN collar.

Part No.	Length	Loading
<b>MHBM2</b>	850mm	1.1kW
<b>MHBM3</b>	1177mm	1.9kW
<b>MHBM4</b>	1504mm	2.7kW



**Heated Displays - Bains Marie**  
Curved glass sneeze screen with side cheeks and flat GN collar.

Part No.	Length	Loading
<b>MHBM2W</b>	850mm	1.1kW
<b>MHBM3W</b>	1177mm	1.9kW
<b>MHBM4W</b>	1504mm	2.7kW

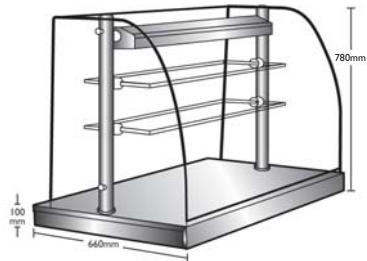

**Ambient Displays - Two Tier**  
Full height glass screen and side cheeks.

Part No.	Length	Loading
<b>MAGH3</b>	1177mm	50W
<b>MAGH4</b>	1504mm	50W



**Ambient Displays - Two Tier**  
Curved glass sneeze screen and side cheeks.

Part No.	Length	Loading
<b>MAGH2W</b>	850mm	50W
<b>MAGH3W</b>	1177mm	50W
<b>MAGH4W</b>	1504mm	50W



**Ambient Displays - One Tier**  
Full height glass screen and side cheeks.

Part No.	Length	Loading
<b>MAGL2</b>	850mm	50W
<b>MAGL3</b>	1177mm	50W
<b>MAGL4</b>	1504mm	50W



**Ambient Displays - One Tier**  
Curved glass sneeze screen and side cheeks.

Part No.	Length	Loading
<b>MAGL2W</b>	850mm	50W
<b>MAGL3W</b>	1177mm	50W
<b>MAGL4W</b>	1504mm	50W



**Refrigerated Displays - One Tier**  
Full height glass screen and side cheeks.

Part No.	Length	Loading
<b>MRGL2</b>	1130mm	0.9kW
<b>MRGL3</b>	1530mm	0.9kW



**Refrigerated Displays - One Tier**  
Curved glass sneeze screen and side cheeks.

Part No.	Length	Loading
<b>MRGL2W</b>	1130mm	0.9kW
<b>MRGL3W</b>	1530mm	0.9kW



Model No. **MRGL2W**  
1130 x 660 x 620mm

**Refrigerated Units**

Refrigerated counter top displays for the Food-to-Go market

- Contact cooled refrigeration system.
- Stainless steel construction.
- Fluorescent illumination to top.
- Full height toughened curved glass screen.
- Removable glass side panels.
- Ambient mid shelf.
- Open to rear.
- Operates with a surface temperature of 0°C to 1°C in ambient temperature of 32°C.
- Two model sizes, open front models also available.
- 13 amp supply.



Model No. **MRGL3**  
1530 x 660 x 620mm

## Heated Display Units

For the simple presentation of heated food. Stainless steel or glass top units designed to accept GN1/1 containers.

### Stainless Steel Top Models

#### Product Features

- Gastronorm compatible top.
- Slimline base.
- 300W operator changeable quartz heat lamps.
- 13 amp supply complete with cable & plug.
- Toughened glass sneeze screen.
- Independent controls to base and gantry.



Model No. **HDU30Z**  
1110 x 580 x 520mm 2kW



Model No. **HDU40Z** – Plain top  
1435 x 580 x 520mm 2.2kW



Model No. **HDU20Z**  
780 x 580 x 520mm 1.35kW

### Glass Top Models



Model No. **HDU20ZG** – Glass top  
780 x 580 x 520mm 1.35kW



Model No. **HDU30ZG** – Glass top  
1110 x 580 x 520mm 2kW



Model No. **HDU40ZG** – Glass top  
1435 x 580 x 520mm 2.2kW

## Chilled Display Units

For the simple presentation of chilled food.

- Gastronorm compatible top.
- Fluorescent illumination to top.
- 13 amp supply complete with plug.
- Complete with Victor StayKold Eutectic plates.
- Toughened glass sneeze screen.

Gastronorm containers are optional extras.



Model No. **CDU30**  
1110 x 580 x 520mm 21W

## Caribbean Toppers - Heated

The Victor range of Caribbean Toppers contains 16 models of counter top food display units that allow the caterer to choose the model that meets their food service requirements.

### Product Features

- Stainless steel base radius to front & rear
- Variable heat control to dry heat only Bains Marie.
- Accepts gastronorm containers up to 65mm deep.
- 13 amp supply complete with cable & plug.
- Heavy duty construction.
- Stainless steel gantry arms and hood.
- 300W operator changeable quartz heat lamps fitted with dimmer control.



Containers not included.

Model No. **CTB2**  
800 x 650 x 635mm 1.35kW

### Extras for Bains Marie

- Carvery insert.
- Tiled inserts.
- Glass inserts.
- Inclined collars to Bains Marie.
- Gastronorm containers.

Model No. **CTB1** 1200 x 650 x 635mm 2.4kW

Containers not included.



Glass insert - **DHCPI**

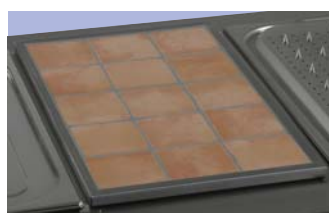

Tiled insert - **DHTPI**



Carvery/Gravy insert - **BMCVI**

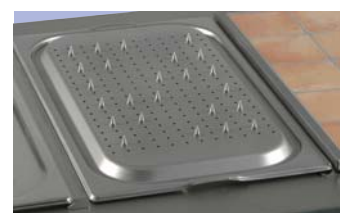

Carvery insert - **BMCV2**

## Caribbean Toppers - Heated

The Victor range of Caribbean Toppers contains 16 models of counter top food display units that allow the caterer to choose the model that meets their food service requirements.

Most heated models are available in two lengths, 800mm & 1200mm, and match in terms of style and profile allowing a flexible food service area to be created.

### Features Included on Heated Models

- Stainless steel base radius to front & rear.
- Variable heat control to base.
- 13 amp supply complete with cable & plug.
- Heavy duty construction.
- Stainless steel gantry arms and hood.
- 300W operator changeable quartz heat lamps fitted with dimmer control.



Model No. **CTGI**  
1200 x 650 x 635mm 1.9kW



Model No. **CTPI**  
1200 x 650 x 635mm 2.4kW



Model No. **CTG2**  
800 x 650 x 635mm 1.1kW



Model No. **CTP2**  
800 x 650 x 635mm 1.35kW

**Carvery Topper**

- Tiled unit complete with one carvery pad and one tiled insert.
- Carvery pad is removable for easy cleaning.
- Choice of carvery pad position.
- Can be swapped from left to right.

**Extras for Carvery Topper**

- Tiled insert to replace carvery pad when not in use.
- Additional carvery pad.



Model No. **CTCI**  
1200 x 650 x 635mm 2.4kW

**Tiled Topper**

Model No. **CTT2**  
800 x 650 x 635mm 1.35kW



Model No. **CTTI**  
1200 x 650 x 635mm 2.4kW

The standard tile colour is terracotta, other tile colours are available to order.

## Special Order Items

**Options to Special Order**

- Coloured gantry arms.
- Alternative gantry styles.
- Brass finish deluxe models.



Carvery topper with curved glass gantry and slate grey tiles

## Caribbean Toppers - Refrigerated

The Victor range of Caribbean Toppers contains 16 models of counter top food display units that allow the caterer to choose the model that meets their food service requirements.

Refrigerated models are available in two lengths, 1100mm & 1500mm, and match in terms of style and profile allowing a flexible food service area to be created.

### Ice Cooled Topper

- Stainless steel base with radius to front & rear.
- Stainless steel well complete with drain tap.
- Compatible with Victor StayKold Eutectic plates.
- Heavy duty construction.
- Stainless steel gantry arms and hood.
- Fluorescent illumination to gantry overshef.
- 13 amp supply complete with cable & plug.
- Toughened glass sneeze screen.

### Extras

- StayKold Eutectic Plates.

### Refrigerated model features

- Stainless steel base radius to front & rear.
- Stainless steel contact cooled well.
- Operates with a surface temperature of 0°C to 1°C in ambient temperatures up to 32°C.
- Heavy duty construction.
- Stainless steel gantry arms and hood.
- Fluorescent illumination to gantry overshef.
- Toughened glass sneeze screen.



Model No. **CTSI** 1200 x 650 x 635mm 0.2kW



Model No. **BTREF1** 1500 x 650 x 260mm 1.0kW

Model No. **BTREF2** 1100 x 650 x 260mm 1.0kW



Model No. **BTREF3** 1500 x 650 x 260mm 1.0kW

Model No. **BTREF4** 1100 x 650 x 260mm 1.0kW



Model No. **CTREF15** 1500 x 650 x 635mm 1.0kW



Model No. **CTREF11** 1100 x 650 x 635mm 1.0kW

# Buffet Toppers

The Victor range of Buffet Toppers contains 8 models of portable counter top heated display units with interchangeable tops to allow flexible service combinations. Each of the four model types are available with or without a quartz heat lamp over.

**Product Features**

- Variable heat control to base.
- Heavy duty stainless steel construction.
- Removable top for cleaning.
- 300W operator changeable quartz heat lamps.

Description	With Heat Lamp Over	No Heat Lamp	Spare Top
Carvery Top	<b>BTC4</b>	BTC5	BTCTOP
Glass Top	<b>BTG4</b>	BTG5	BTGTOP
Tiled Top	<b>BTT4</b>	BTT5	BTTTOP
Stainless Steel Top	<b>BTP4</b>	BTP5	BTPTOP

**Dimensions**

With Heat Lamp 400 x 400 x 550mm 0.6kW loading  
 Without Heat Lamp 400 x 400 x 115mm 0.3kW loading

**Extras**

- Freestanding perspex screen 500 x 250 x 400mm
- Alternative tops



Model No. **BTC5**

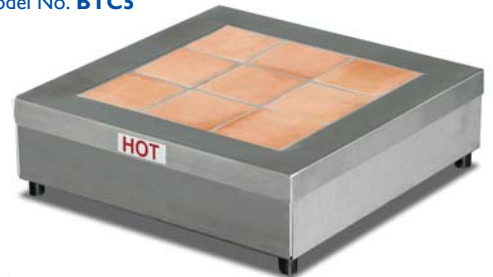

Model No. **BTT5**



Model No. **BTG5**



Model No. **BTP5**



Model No. **BTP4**

Model No. **BTT4**

Model No. **BTG4**

Model No. **BTC4**

## Hot Lamp Units

A choice of four models each with stainless steel top and body panels. Heated by tubular elements to base and copper effect light shades enclosing infrared heat bulbs. Units are complete with a height adjustable acrylic sneeze screen which can be set in a high or low position as shown.



Model No. **QL**  
1275 x 615 x 735mm 2.9kW



Model No. **TL**  
805 x 505 x 735mm 1.6kW



Model No. **DL**  
725 x 505 x 735mm 1.3kW

## Hot Plates

- Stainless steel top and body panels.
- Variable heat control
- Neon indicator light.
- Removable wooden carrying handles.



Model No. **HP1**  
600 x 300 x 115mm 0.3kW

Model No. **HP2**  
800 x 300 x 115mm 0.4kW

Model No. **HP3**  
1000 x 300 x 115mm 0.85kW

Model No. **HP4**  
1000 x 500 x 115mm 0.85kW

## Burger Chute

Constructed in stainless steel, with two inclined heated shelves and fluorescent light to both levels. Each shelf has a separate thermostat control and removable space dividers. The large unit holds twelve rows of burgers, smaller unit holds eight rows of burgers.

Designed for rear stocking, burger chutes can speed up the service of popular items.

Burger Chutes can be supplied separate or with a compatible Jamaican base unit in a choice of 14 plastic coated steel colour options.

- Two inclined heated shelves.
- Holds up to twelve rows of heated product.
- Fluorescent illumination to each level.
- Thermostatic temperature control.
- Compatible with Victor Jamaican base units.
- Two sizes available.
- Complete with 13 amp plug.



**BC30** 1050 x 600 x 755mm 3kW  
**BC20** 720 x 600 x 755mm 2kW

BC30 Shown on 1200  
Jamaican base unit

## Hot Food Merchandising

### Hot Food Merchandising

Victor Hot Food Merchandising units contain a 1.5kW heating element that enables refrigerated savoury products to be heated ready for serving. When the display product is ready for sale the unit can be turned down to keep the product at the required temperature.



Model No. **HMU50**  
470 x 470 x 790mm 1.5kW

### Specification

- Stainless steel and glass cabinet.
- Stylish moulded dome top.
- Internal illumination to top.
- Thermostatic temperature control.
- Humidity tray.
- Slide out crumb tray.
- Complete with 13 amp plug.
- Three tier square rack.

### Pizza Version

- Rotating 4 tier pizza rack.
- Accepts pizzas up to 355mm diameter.
- Manual or electric rotating model options.



Model No. **HMU50PIZM** – Manual 470 x 470 x 790mm 1.5kW  
Model No. **HMU50PIZA** – Automatic 470 x 470 x 790mm 1.5kW

## Counter Units



### Counter Units

- Adjustable thermostat control.
- Stainless Steel Construction.
- Sliding glass door to front.
- Operates from 13 amp supply.

Model No. **CU**  
725 x 350 x 490mm 0.7kW



Model No. **SPM75**  
760 x 510 x 640mm 1.0kW  
Sliding glass door to front and back.

# Victor

# Toppers

Victor Manufacturing Limited.

Lonsdale Works

Gibson Street

Bradford BD3 9TF

Tel: 01274 722125

Fax: 01274 307082

[email@victormanufacturing.co.uk](mailto:email@victormanufacturing.co.uk)

[www.victoronline.co.uk](http://www.victoronline.co.uk)



VML030  
09/09