

# optris<sup>®</sup> BR 400

---

Calibration source



Operators manual



---

## CE-Conformity

The product complies with the following standards:



EMC: EN 61326-1:2006 (Basic requirements)  
EN 61326-2-3:2006  
Safety: EN 61010-1:2001

The product accomplishes the requirements of the EMC Directive 2004/108/EG and of the Low Voltage Directive 2006/95/EG.

Read the manual carefully before the initial start-up. The producer reserves the right to change the herein described specifications in case of technical advance of the product.

**Optris GmbH**  
**Ferdinand-Buisson-Str. 14**  
**D – 13127 Berlin**  
**GERMANY**

**Tel.: +49-30-500 197-0**  
**Fax: +49-30-500 197-10**

**E-mail: [info@optris.de](mailto:info@optris.de)**  
**Internet: [www.optris.com](http://www.optris.com)**

## Warranty

Each single product passes through a quality process. Nevertheless, if failures occur please contact the customer service at once. The warranty period covers 24 months starting on the delivery date. After the warranty is expired the manufacturer guarantees additional 6 months warranty for all repaired or substituted product components. Warranty does not apply to electrical fuses or damages, which result from misuse or neglect. The warranty also expires if you open the product. The manufacturer is not liable for consequential damage. If a failure occurs during the warranty period the product will be replaced, calibrated or repaired without further charges. The freight costs will be paid by the sender. The manufacturer reserves the right to exchange components of the product instead of repairing it. If the failure results from misuse or neglect the user has to pay for the repair. In that case you may ask for a cost estimate beforehand.

---

## Content

	Page		Page
<b>Description</b>	<b>3</b>	<b>Calibration of Infrared Thermometers</b>	<b>16</b>
<b>Scope of Supply</b>	<b>4</b>	Transfer standard	17
<b>Maintenance</b>	<b>4</b>	ITS-90	18
<b>Specification</b>	<b>5</b>	Calibration Geometry	19
General Specification	5	Calibration	22
Electrical Specification	5		
Controller Specification	5		
Measurement Specification	6		
<b>Operation</b>	<b>7</b>		
Installation	7		
Control Elements	7		
Switch On	9		
Setup of the Set Point Value	9		
Lock of Programming Keys	9		
Advices for Operation	10		
<b>Circuit Diagram</b>	<b>11</b>		
<b>Troubleshooting</b>	<b>12</b>		
<b>Basics of Infrared Thermometry</b>	<b>13</b>		
<b>Emissivity</b>	<b>14</b>		
Definition	14		
Determination of unknown Emissivities	14		
Characteristic Emissivities	15		

---

## Description

Thank you for choosing the **optris® BR 400** calibration source.

The BR 400 is a rugged calibration source and can be used for calibration and check up of infrared thermometers. It contains of three main components:

- Radiation surface
- Heater
- Temperature controller and Pt100 probe

The radiation surface is made of aluminium with a special thermal conductivity and V-shaped grooves. The temperature of this surface is controlled by a Pt100.

The maximum deviation between the surface temperature and the temperature at the contact point of the Pt100 is 0,1% ( $T_{max}=0,1\%$ ).

All radiation surfaces are produced in a special black-finishing process, which guarantees a high quality and high uniformity of the surface. A special coating realizes a high emissivity of the surface in the infrared spectrum.

**To avoid a damage of the special coating, please do not touch the radiation surface with sharp or spiky objects.**

On the top section of the black body you will find a hole. You can place a thermocouple probe here for an external monitoring of the radiator temperature.

---

## Scope of supply

- BR400 calibration source
- Operators manual
- Test log (according DIN VDE 0702)
- Calibration certificate

You will find the serial number on the unit. Always use this number when you contact the customer service concerning maintenance, additional order of components, spare parts or repairs.

## Maintenance

**Cleaning the housing:** To clean the exterior housing use a humid tissue (wetted with water or a mild commercial cleaner).

**PLEASE NOTE: Never use cleaning compounds which contain solvents.**

---

## Specification

### General Specification

Ambient temperature:	0...50°C (during operation)
Weight:	4,5 kg
Dimensions:	325 mm x 230 mm x 230 mm

### Electrical Specification

Temperature sensor:	Pt100
Controller:	PID
Power supply:	230 V AC ( $\pm 10\%$ ), 50 Hz
Power consumption:	max. 1000 W

### Controller Specification (preset)

P = 1  
I = 105  
D = 26

**NOTE:** The controller parameters are factory preset for an optimum of performance and safety operation of the black body calibration source.

Please do not change these values [**EXPIRY OF WARRANTY**].

---

## Measurement Specification

Temperature range:	$T_{\text{amb}}+5\text{ °C}$ to 400 °C
Accuracy <sup>1)</sup> :	$\pm 0,5\text{ °C}$ at 50 °C $\pm 1,0\text{ °C}$ at 100 °C $\pm 1,3\text{ °C}$ at 250 °C $\pm 2,0\text{ °C}$ at 400 °C
Temperature resolution:	0,1°C
Aperture diameter:	128 mm
Emissivity:	0,97 $\pm$ 0,02 at 8-14 $\mu\text{m}$
Warm-up time:	15 min. (from 25 °C to 100 °C) 40 min. (from 25 °C to 400 °C)
Cool-down time:	60 min. (from 100 °C to 50 °C) 90 min. (from 400 °C to 50 °C)

<sup>1)</sup> For IR thermometers with a spectral sensitivity of 8-14  $\mu\text{m}$  and an emission factor between 0,9 and 1,0.  
For an exactly determination of the radiation temperature of the calibration source we recommend the use of a reference IR thermometer (e.g. optiris LS DCI). ► **Calibration of Infrared Thermometers**

---

## Operation

### Installation

You can position the BR 400 on a laboratory bench or any other suitable flat and stable surface. **Please take care in any case that the BR400 is positioned horizontal!**

Connect the unit to the 230 V mains using the supplied cable.

### Control Elements

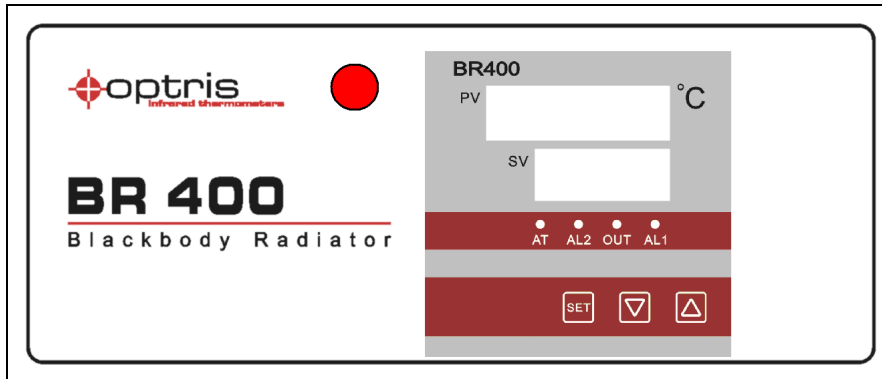

Front panel of BR400 with PID controller and red power lamp (left hand side of controller)

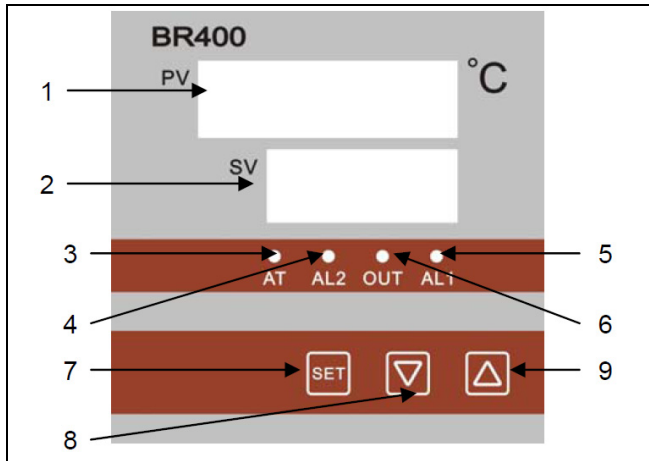

### PID-controller (front side)

- 1 Upper display (PV)
- 2 Lower display (SV)
- 3 LED for auto adjust
- 4 LED for lower alarm output
- 5 LED for upper alarm output
- 6 LED for heating
- 7 Function key
- 8 Down key
- 9 Up key

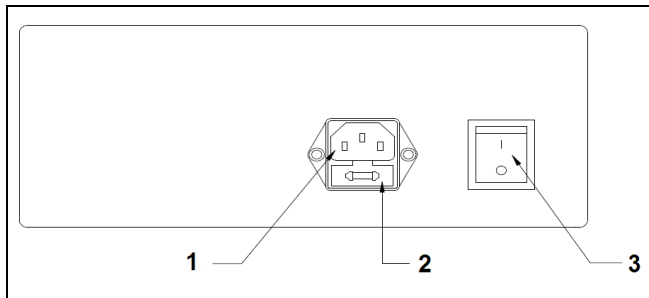

### Back side

- 1 Power socket
- 2 Fuse 5A
- 3 Mains switch

---

## Switch On

After the installation of the unit you can switch on the main switch **[3]** on the back side. The controller display on the front will show the temperature set point **[lower display – SV]** and the current temperature of the black body **[upper display – PV]**. The internal ventilator is working permanently during operation.

## Setup of the Set Point Value

Please push the **Up** key **[9]** or **Down** key **[8]** to set up the desired temperature value. After the desired set point is shown in the lower display, the BR400 will start to heat up.

Dependent from the difference between current black body temperature and set point value this process can take up to **40 minutes (from 25 °C to 400 °C)**.

## Lock of Programming Keys

With this function you can lock the programming keys on the controller of the BR400 to avoid a non authorized change of parameters on the unit.

To lock the controller please press the **Function** key **[7]** for some seconds until **LC** is shown in the upper display **[1]**. Then release the **Function** key and press the **Up** key or **Down** key to change the value in the range of 0...2. The values have the following meaning:

- 0**      **All parameters can be changed**
- 1**      **Only P, D, I and temperature set point can be changed**
- 2**      **No change is possible**

---

## Advices for Operation

For an exactly check or for a calibration of infrared thermometers it is necessary, that the used calibration sources are in a steady state. For this reason please consider the specified warm-up time of the BR400.

### ► Specification

Please take care of the optical beam of infrared thermometers (D:S ratio) and the calibration geometry (distance to the black body) if you check or calibrate them. Contact the supplier of the thermometer to get more detailed information if necessary.

### ► Calibration of Infrared Thermometers

**It is possible that the housing of the BR 400, dependent from the selected temperature, can get warm or hot. Do not put any materials or objects on the radiator housing! The ventilation outlet on the back side as well as the radiation aperture on the front must not be covered by materials or objects!**

Before you switch off the BR 400, please setup the set point to **0 °C**. After the black body temperature is below **200 °C [upper display – PV]** you can turn off the main switch on the back side.

## Circuit Diagram

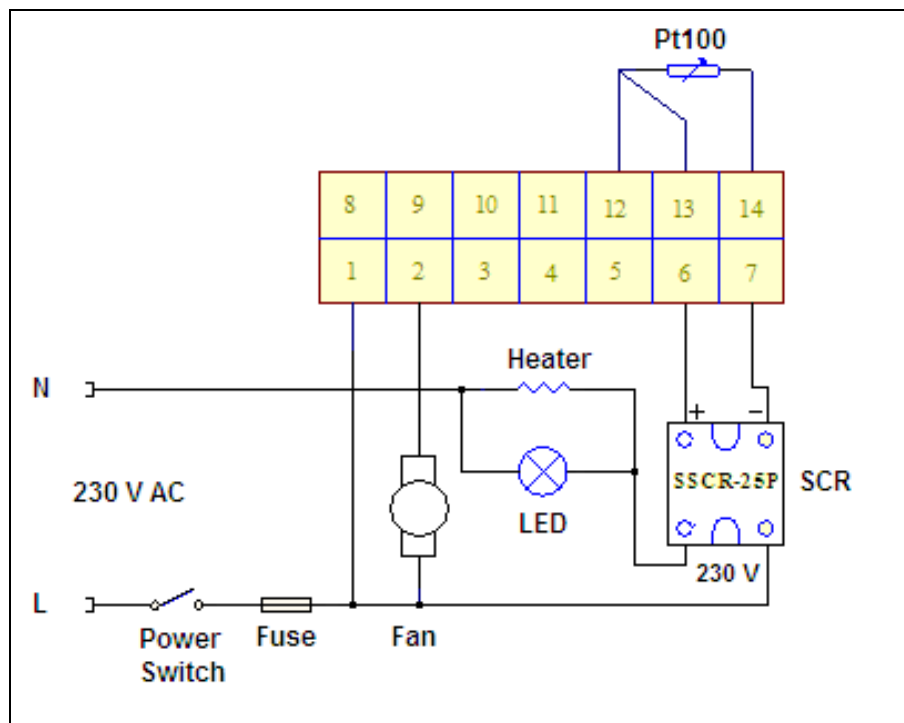

---

## Troubleshooting

Problem	Reason/ Action
no display after switch on	Check the mains connection Check the fuse
upper display: HH	Please contact the service
after switch on the upper display is showing: LL/ all LED are flashing	Mains voltage too low
Black body is not heating although properly setup	Set point value lower than current temperature

In case of problems or questions, which may arise when you use the optris® BR 400, please contact our service department. The customer service staff will support you with questions concerning the optimization of the work with the calibration source, calibration procedures or with repairs.

---

## Basics of Infrared Thermometry

Depending on the temperature each object emits a certain amount of infrared radiation. A change in the temperature of the object is accompanied by a change in the intensity of the radiation. For the measurement of “thermal radiation” infrared thermometry uses a wave-length ranging between 1  $\mu$  and 20  $\mu$ m.

The intensity of the emitted radiation depends on the material. This material contingent constant is described with the help of the emissivity which is a known value for most materials (see enclosed table emissivity).

Infrared thermometers are optoelectronic sensors. They calculate the surface temperature on the basis of the emitted infrared radiation from an object. The most important feature of infrared thermometers is that they enable the user to measure objects contactless. Consequently, these products help to measure the temperature of inaccessible or moving objects without difficulties. Infrared thermometers basically consist of the following components:

- lens
- spectral filter
- detector
- electronics (amplifier/ linearization/ signal processing)

The specifications of the lens decisively determine the optical path of the infrared thermometer, which is characterized by the ratio Distance to Spot size.

The spectral filter selects the wavelength range, which is relevant for the temperature measurement. The detector in cooperation with the processing electronics transforms the emitted infrared radiation into electrical signals.

---

## **Emissivity**

### **Definition**

The intensity of infrared radiation, which is emitted by each body, depends on the temperature as well as on the radiation features of the surface material of the measuring object. The emissivity ( $\epsilon$  – Epsilon) is used as a material constant factor to describe the ability of the body to emit infrared energy. It can range between 0 and 100 %. A “blackbody” is the ideal radiation source with an emissivity of 1,0 whereas a mirror shows an emissivity of 0,1.

If the emissivity chosen is too high, the infrared thermometer may display a temperature value which is much lower than the real temperature – assuming the measuring object is warmer than its surroundings. A low emissivity (reflective surfaces) carries the risk of inaccurate measuring results by interfering infrared radiation emitted by background objects (flames, heating systems, chamottes). To minimize measuring errors in such cases, the handling should be performed very carefully and the unit should be protected against reflecting radiation sources.

### **Determination of unknown Emissivities**

- ▶ First, determine the actual temperature of the measuring object with a thermocouple or contact sensor. Second, measure the temperature with the infrared thermometer and modify the emissivity until the displayed result corresponds to the actual temperature.
- ▶ If you monitor temperatures of up to 380°C you may place a special plastic sticker (emissivity dots – part number: ACLSED) onto the measuring object, which covers it completely. Now set the emissivity to 0,95 and take the temperature of the sticker. Afterwards, determine the temperature of the adjacent area on the measuring object and adjust the emissivity according to the value of the temperature of the sticker.

- 
- Cove a part of the surface of the measuring object with a black, flat paint with an emissivity of 0,98. Adjust the emissivity of your infrared thermometer to 0,98 and take the temperature of the colored surface. Afterwards, determine the temperature of a directly adjacent area and modify the emissivity until the measured value corresponds to the temperature of the colored surface.

**CAUTION: On all three methods the object temperature must be different from ambient temperature.**

### **Characteristic Emissivities**

In case none of the methods mentioned above help to determine the emissivity you may use emissivity tables. These are average values, only. The actual emissivity of a material depends on the following factors:

- temperature
- measuring angle
- geometry of the surface
- thickness of the material
- constitution of the surface (polished, oxidized, rough, sandblast)
- spectral range of the measurement
- transmissivity (e.g. with thin films)

---

## Calibration of Infrared Thermometers [1] [2]

In this chapter the general procedure and important relationships for the calibration of infrared thermometers are explained. For a detailed description of the different calibration methods and a detailed uncertainty consideration we recommend the standard VDI/ VDE 3511 part 4.3 Calibration of radiation thermometers.

Infrared thermometers are calibrated with the help of reference radiation sources, so called black bodies. These radiation sources can produce different radiation temperatures with a high stability which are used to determine the calibration constants of the infrared thermometers. For the calibration process it is of essential importance to know the exact value of the radiation temperature. It can be measured either by using a contact thermometer (in combination with the determination of the emissivity) or by using a transfer standard infrared thermometer.

The emissivity of an ideal radiation source would be 1,00 for all wavelengths and emission angles. From all real existing sources cavity radiation sources are achieving the best results (emissivity values up to 0,999). The emissivity of a plate radiation source is strongly dependent on the surface properties and is typically at 0,96.

**For the here described calibration method the knowledge of the exact emissivity value of the used radiation source is not necessary.**

For the initial factory calibration Optris is defining the calibration temperatures in a way that all constants can be determined with the best possible accuracy. For a re-calibration by the user or a local calibration laboratory the calibration temperatures should be selected close to the temperatures of the specific application or, if not known, according to the rule:

- low end of range +10% of the infrared thermometer or room temperature
- middle of the temperature range
- high end of range -10%

## Transfer standard

Optris is using a traceable transfer standard radiation thermometer (in the following text mentioned as LS-PTB) to measure the radiation temperature of the reference source. As the LS-PTB needs to be traceable to the ITS-90, the PTB (Physikalisch-Technische Bundesanstalt – the German national metrology institute) is calibrating this instrument in regular periods.



Transfer standard IR thermometer LS-PTB



Reference IR thermometer LS-DCI

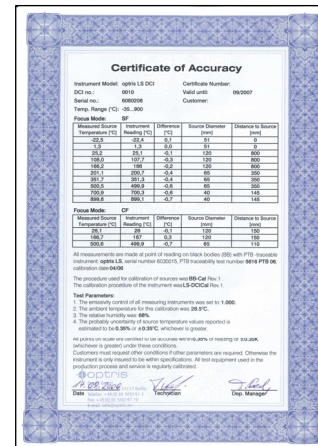

Certificate of calibration for LS-DCI

---

The LS-DCI is a reference IR thermometer which is based on the portable IR thermometer series optris LS. The units are produced with pre-selected components supporting a high stability of measurement. In combination with a dedicated calibration at several points the LS-DCI achieves a higher accuracy than units out of the series production and is therefore qualified to be used as dedicated calibration instrument (DCI).

## ITS-90

The 1990 International Temperature Scale (ITS-90) prescribes a system of measurement devices and methods that ensure a uniform temperature measurement worldwide. The ITS-90 is a very good approximation of the thermodynamic temperature. It is based on 17 well reproducible fixed points like melting points of highly pure metals.

The calibration process makes the measurement with an infrared thermometer traceable to ITS-90. To achieve this, the infrared thermometers are compared within a closed chain of comparative measurements with a known uncertainty with the national temperature standards from the PTB.

Fixed point	Temperature/ K	Temperature/ °C
Triple point of Mercury [Hg]	234,3156	-38,8344
Triple point of Water [H <sub>2</sub> O]	273,16	0,01
Melting point of Gallium [Ga]	302,9146	29,7646
Melting point of Indium [In]	429,7485	156,5985
Melting point of Tin [Sn]	505,078	231,928
Melting point of Zinc [Zn]	692,677	419,527
Melting point of Aluminium [Al]	933,473	660,323
Melting point of Silver [Ag]	1234,93	961,78

**Fixed points of the ITS-90 (Selection) [Source: [www.its-90.com/](http://www.its-90.com/) 12.01.2012]**

For the calibration of the transfer standard radiation thermometers the PTB is using high-precision heat pipes. Due to different temperature stabilization procedures in combination with a high thermal mass of the cavities these heat pipes are reaching a high temperature stability of  $\pm 10$  mK.

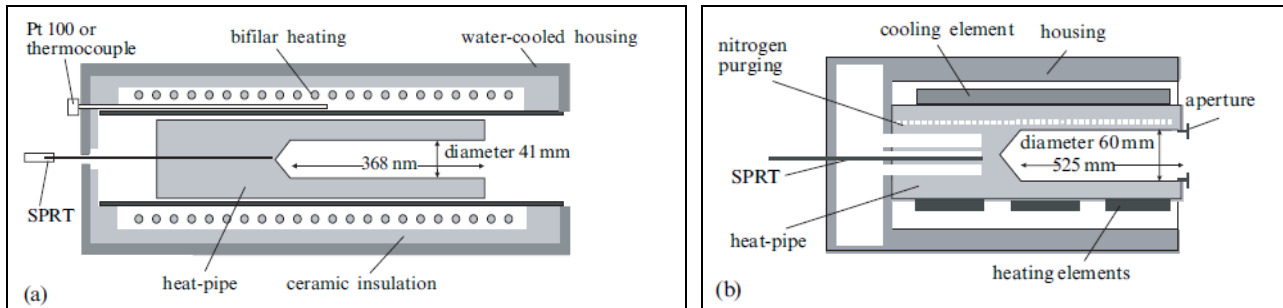

**Schematic layout of heat pipes used at the PTB: sodium and caesium heat pipes (a) / water and ammonia heat pipes (b) [3]**

## Calibration Geometry

The optics of an IR thermometer is described by the distance to spot ratio (D:S). Depending on the quality of the optics a certain amount of radiation is also received from outside the specified measurement spot. The signal change in correlation with a resize of the radiation source is described by the Size-of-source effect (SSE).

The radiation maximum which the IR thermometer is receiving equals the radiation of a hemispheric radiation source. Therefore the value which is specified in datasheets and technical documentation as measurement

spot is in general a certain defined percentage of this radiation maximum – values of 90% or 95% are common. Consequently all manufacturers of IR thermometers are using accurately defined geometries for the calibration of their units; means depending on the aperture of the radiation source (**A**) a distance (**a**) between the IR thermometer and the reference source is defined.

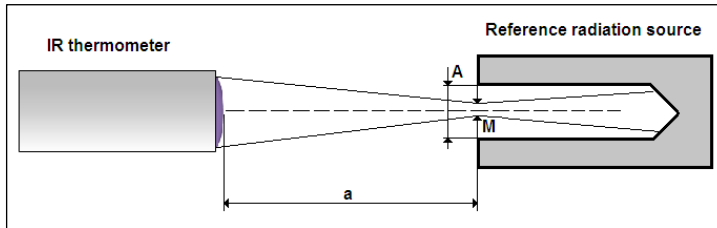

- A** Diameter of the effective area of the reference radiation source
- M** Measurement spot of the IR thermometer at distance a
- a** Measurement distance

### Calibration geometry

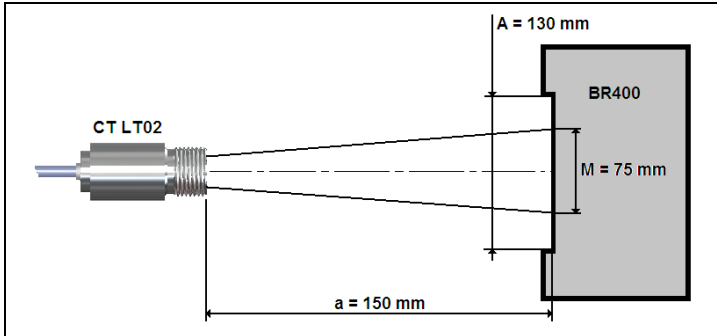

**Example: Calibration geometry of the optris CT LT02 on a BR400 source**

Product	model	Source up to 400°C Ø: 130 mm	Source up to 550°C Ø: 65 mm	Source up to 1200°C Ø: 30 mm	Source up to 500°C Ø: 51 mm
<b>Calibration distances</b>					
optris CT	LT02	150 mm	90 mm		
	LT15	210 mm	150 mm		
	LT20	210 mm	150 mm		
optris CTlaser LT	LTCF1		110 mm		
	LTCF2		150 mm		
	LTCF3		200 mm		
	LTCF4		350 mm		
	LTSF		350 mm		
optris CTlaser 1M, 2M, 3M		150 mm	90 mm	60 mm	
optris CT 1M, 2M, 3M		150 mm	90 mm	60 mm	
optris CS		210 mm	150 mm		
optris CSmicro		210 mm	150 mm		
optris LS	SF mode	800 mm	350 mm		250 mm
	CF mode		110 mm		
optris PI	80°	240 mm			100 mm
	48°/ 64°	650 mm	325 mm	150 mm	250 mm
	23°/ 31°	780 mm	390 mm	180 mm	300 mm
	6°/ 9°	2300 mm	1200 mm	540 mm	900 mm

**Calibration geometries for Optris IR thermometers (selection – the complete list can be ordered)**

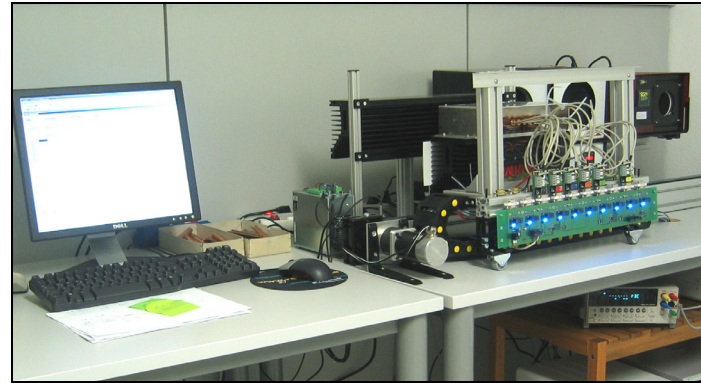
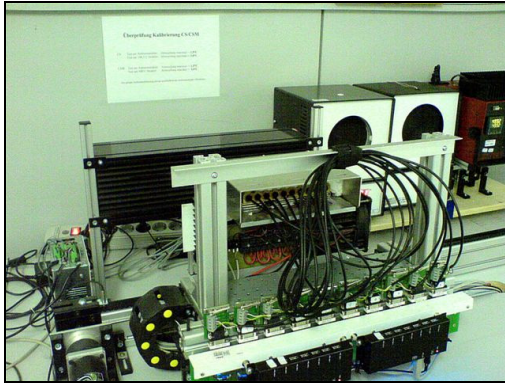

**Automated calibration stations at Optris GmbH**

## **Calibration**

The basic requirements for a calibration laboratory are:

- Laboratory room with stable temperature and humidity
- Measurement equipment for air temperature and humidity
- Reference radiation source
- Traceable transfer standard radiation thermometer (e.g. LS-PTB) or a dedicated calibration instrument (e.g. LS-DCI)
- Adjustable holder for the infrared thermometer

For creating calibration certificates beside the laboratory temperature and humidity also the measurement distance and source diameter (calibration geometry) should be documented.

## Calibration procedure:

1. Checking the optics of the LS-PTB/ LS-DCI and of the test unit – cleaning, if necessary
2. Switch on both units; consider warm-up time
3. Set the emissivity value to 1,00 on both units, if possible
4. Set the reference radiation source to a temperature which is significantly different to the internal temperature of the LS-PTB/ LS-DCI; wait for stabilization of the radiation source
5. Bring the LS-PTB/ LS-DCI into measurement position <sup>1)</sup> and determine the radiation temperature of the reference source
6. Bring the test unit into measurement position <sup>1)</sup> and note the reading <sup>2)</sup>
7. Set up the next radiation temperature; wait for stabilization of the source; repeat point 5 and 6

<sup>1)</sup> Determination of the measurement position:

- Put the unit at distance **a** centered to the aperture of the radiation source (for this purpose an adjustable aperture which is placed in front of the source can be helpful)
- Set the aperture to 0,9 x measurement spot size
- Adjust the unit to the center of the aperture via maximum search
- After this please open the aperture to 100% of the calibration geometry or remove it

<sup>2)</sup> On portable IR thermometers reading stands for the shown temperature on the display. For online IR thermometers the signal at the analog output has to be measured. The function  $T_{\text{Rad}} = f(\text{signal})$  must be known.

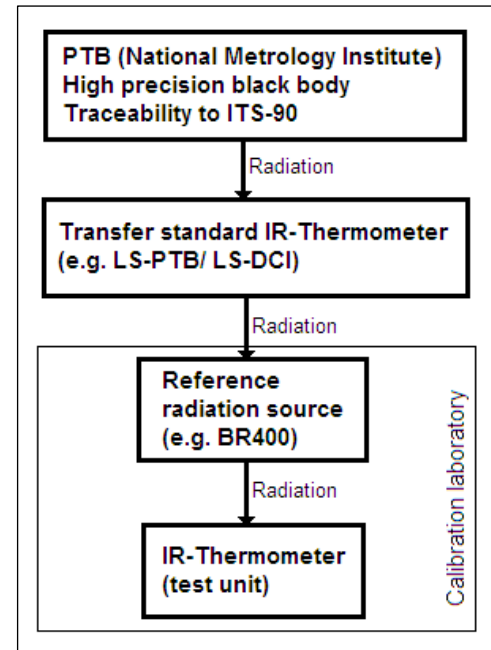

---

## Literature

[1] VDI/ VDE Standard: Temperature measurement in industry – Specification for radiation thermometers, 2001, VDI/ VDE 3511, Part 4.1

[2] VDI/ VDE Standard: Temperature measurement in industry, Radiation thermometry – Calibration of radiation thermometers, 2004, VDI/ VDE 3511, Part 4.3

[3] Jörg Hollandt, Rüdiger Friedrich, Berndt Gutschwager, Dieter R Taubert, Jürgen Hartmann – High-accuracy radiation thermometry at the National Metrology Institute of Germany, the PTB;  
Published in: High Temperatures - High Pressures, 2003/2004, volume 35/36, pages 379 - 415