

optris[®] PI NetBox

Mini PC for optris PI series



Operators manual

CE-Conformity

The product complies with the following standards:

EMC:	EN 61326-1:2006 (Basic requirements)
	EN 61326-2-3:2006
Safety Regulations:	EN 61010-1:2001

The product accomplishes the requirements of the EMC Directive 2004/108/EG and of the Low Voltage Directive 2006/95/EG.



Optris GmbH
Ferdinand-Buisson-Str. 14
D – 13127 Berlin
GERMANY

Tel.: +49-30-500 197-0
Fax: +49-30-500 197-10

E-mail: info@optris.de
Internet: www.optris.com

Read the manual carefully before the initial start-up. The producer reserves the right to change the herein described specifications in case of technical advance of the product. References to other chapters are marked as [► ...].

Warranty

Each single product passes through a quality process. Nevertheless, if failures occur please contact the customer service at once. The warranty period covers 24 months starting on the delivery date. After the warranty is expired the manufacturer guarantees additional 6 months warranty for all repaired or substituted product components. Warranty does not apply to damages, which result from misuse or neglect. The warranty also expires if you open the product. The manufacturer is not liable for consequential damage or in case of a non-intended use of the product. If a failure occurs during the warranty period the product will be replaced, calibrated or repaired without further charges. The freight costs will be paid by the sender. The manufacturer reserves the right to exchange components of the product instead of repairing it. If the failure results from misuse or neglect the user has to pay for the repair. In that case you may ask for a cost estimate beforehand.

Content

	Page		Page
Description	3	Ethernet Direct Communication	23
Scope of Supply	3	Ethernet Network Communication	30
Maintenance	4	Stand-alone Operation	34
Cautions	4	System time	36
Technical Data	5	Write protection filter	37
General Specifications	5	System Recovery	39
Electrical Specifications	5		
Installation	6		
Controls and Connections	7		
Protective Housing	8		
Operation	10		
Operation Modes	10		
SD Card	10		
Status LEDs	11		
Switch Positions	12		
Remote Access to the NetBox	13		
Applications and Start Options	16		
Watchdog	20		
Autostart	21		
File transfer between NetBox and PC	22		

Description

The optris PI NetBox is a miniaturized PC which expands the optris PI series to a stand-alone solution or which works as a USB to Ethernet converter. This mode generates larger possible distances between process (IR camera) and process control (PC).

The NetBox includes a Windows XP Professional operating system that allows the user to install additional software.

The housing of the NetBox is made of anodized aluminum – the optional NetBox protection housing supports the usage in industrial environments (IP65/ NEMA-4 rating).

Scope of Supply

- NetBox incl. micro SDHC card (8 GB)
- Power supply (100-240 VAC / 24 VDC)
- TV_{out} adapter cable
- Ethernet cable, 1 m
- USB Recovery stick (2 GB)
- Rail mount adapter
- Operators manual



Maintenance

The housing of the NetBox can be cleaned with a soft, humid tissue moistened with water or a water based cleaner.

PLEASE NOTE: Never use cleaning compounds which contain solvents. Take care that no moisture infiltrates into the housing.

Cautions

Take care that no foreign substances penetrate into the venting slots of the NetBox. In case of problems or questions which may arise when you use the NetBox, please contact our service department.

**Please use only the threads in the housing or the supplied rail mount adapter for mechanical installation of the NetBox.
Avoid mechanical violence – this may destroy the system (expiry of warranty).**

Technical Data

General Specifications

Operating temperature	0...50 °C
Storage temperature	-20...75 °C
Relative humidity	10...95 %, non condensing
Material (housing)	Anodized aluminum
Dimensions	113 mm x 57 mm x 48 mm (L x W x H)
Weight	315 g
Vibration	IEC 68-2-6: 3G, 11 – 200 Hz, any axis
Shock	IEC 68-2-27: 50G, 11 ms, any axis
Operating system	Windows XP Professional

Electrical Specifications

Power supply	8...48 VDC or Power over Ethernet (PoE/ 1000BASE-T)
Power consumption	9,5 W (+ additional 2,5 W for IR camera)
Cooling	passive (active via integrated fans for ambient temperatures > 50 °C)
Board	COM Express mini embedded board
Processor	Intel® Atom™ Z530/ 1,6 GHz
Hard disc	2 GB SSD
RAM	512 MB (DDR2, 533 MHz)
Ports	3x USB 2.0 1x Mini-USB 2.0 (slave mode) VGA/ TV _{out} Ethernet (Gigabit Ethernet)
Extensions	microSDHC card (up to 32 GB)
Additional functions	6x Status LEDs (L1-L6)

Installation

The NetBox can be mounted easily on a DIN rail (TS35) according EN50022 using the supplied rail mount adapter. For this purpose please screw the 4 screws (M4) into the designated holes on the upper side of the NetBox housing. Now you can place the rail mount adapter on the housing and fix it with the 4 nuts. On the bottom side of the NetBox housing you will find 4 holes M2,5 which also can be used for mounting.

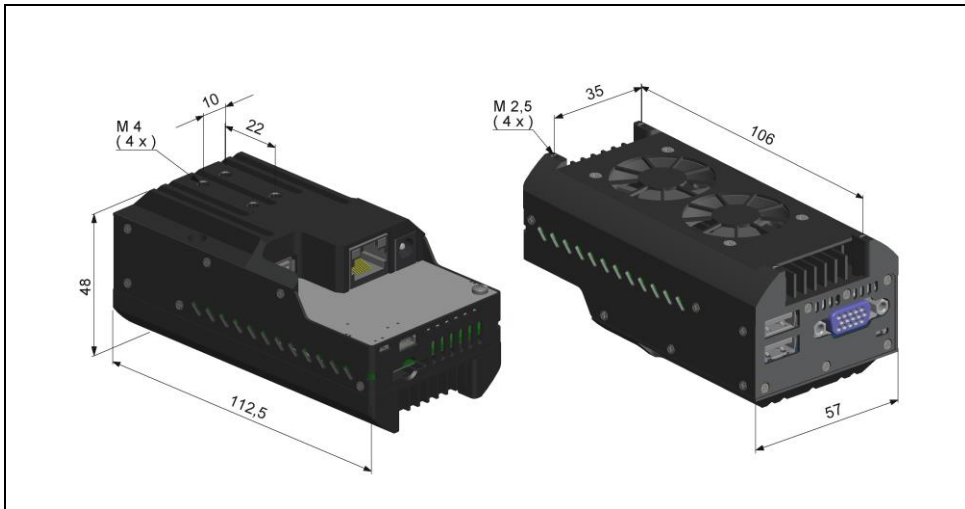

Dimensions NetBox

Controls and Connections

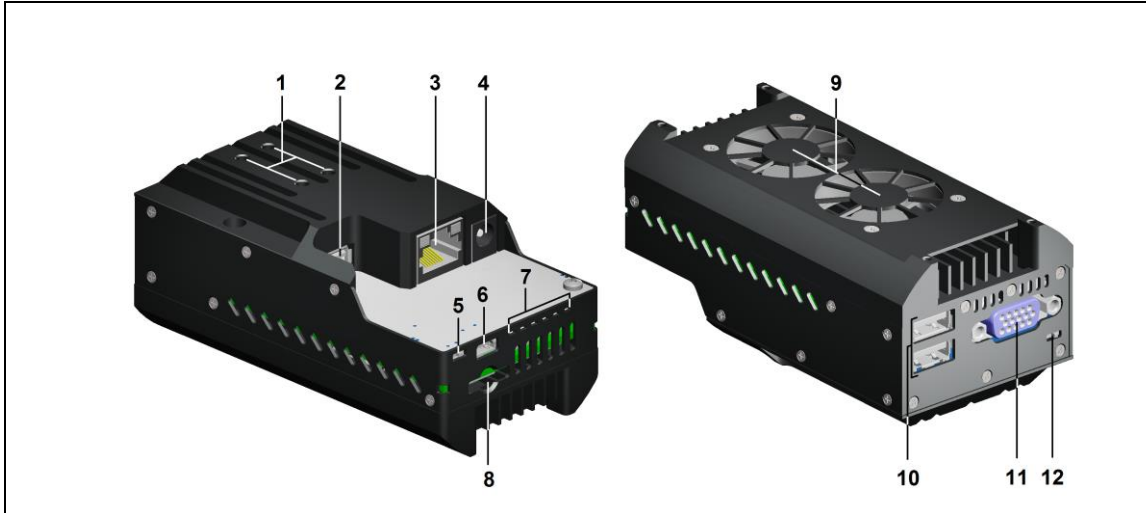

- 1 Mounting holes for rail mount adapter
- 2 USB 2.0 socket
- 3 Ethernet socket
- 4 Power supply socket
- 5 Mode switch (S1/ S2)
- 6 Mini USB socket (slave mode)
- 7 Status-LEDs (L1-L6)
- 8 microSDHC card slot

- 9 Cooling fans
- 10 2x USB 2.0 sockets
- 11 VGA-/ TV_{out}-connection
- 12 Switch VGA/ TV_{out}

Protective Housing

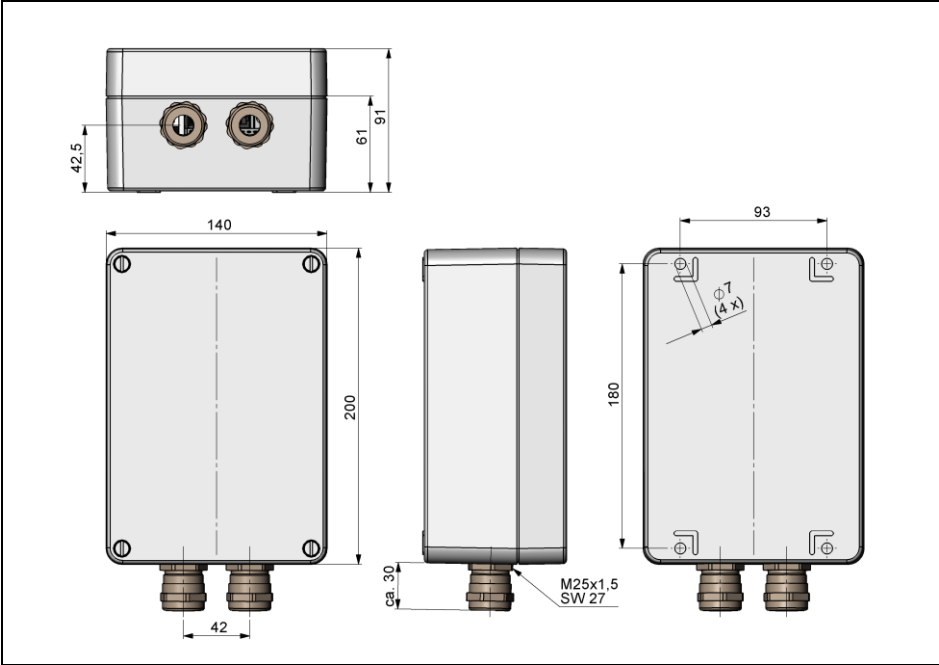

IP65 Protective housing (Alu die-cast) [ACPINBPH]

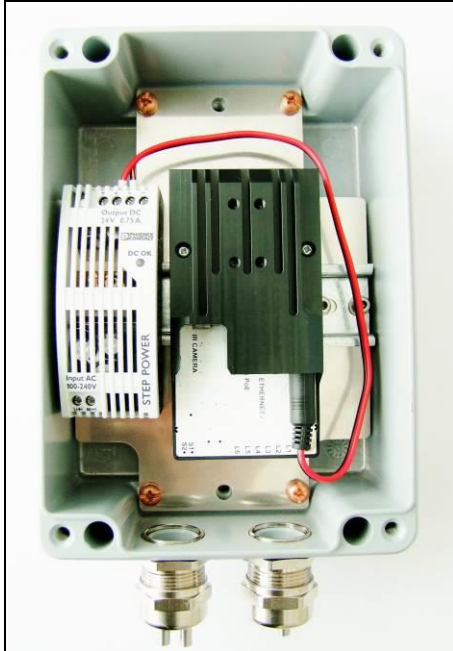

Protective housing with power supply [ACPINBPHPS]



IR camera inside CoolingJacket, connected to a NetBox via high temperature USB cable

Operation

Operation Modes

The NetBox can be used in three different operation modes:

1. Converter USB – Ethernet with direct connection to a PC (point-to-point connection)
2. Converter USB – Ethernet with connection of a PC via a network or via the internet
3. Stand-alone operation with an IR camera

For powering the NetBox you either can use the supplied power adapter or a suitable industrial power supply with a voltage output between 8 VDC and 48 VDC [► **Technical Data**].

Alternatively the NetBox can also be powered via the Ethernet cable (PoE – Power over Ethernet). For this purpose a PoE injector is needed [part#: ACPIPOE].

SD Card

The NetBox will be delivered with a 8 GB SDHC card which is already installed on the unit. If required you can exchange this card. The NetBox is supporting SD cards up to **32 GB** capacity. To remove the card please take a ball pen or similar and push onto the card from outside carefully. Please take care when you insert a card that it is placed correctly into the according guide slot.

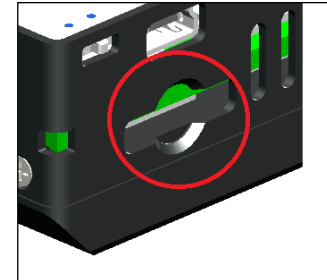

Status LEDs

The NetBox is equipped with 6 status LEDs (L1-L6).

LED	Function	LED lights up if...
L1	Power	NetBox is powered via PoE or by power supply (via power connector)
L2	Power out	NetBox is powered via PoE and (in this case) supplies 12V at the power connector
L3	Net data	video frames are continuously transmitted through the network connection (flashing)
L4	USB data	the imager is connected to an USB port, calibration files are loaded, and raw data frames are continuously delivered by the imager (flashing)
L5	Application OK	the main application (PIConnect or Imager Net Server) is running
L6	Mini USB port	a PC is connected to the mini USB port

Switch Positions

The mode switch is set default to S1. At position S2 the IR camera which is connected to the USB-A socket will be linked directly with the Mini-USB socket. With this you get a direct access to the IR camera from a PC which is connected to the Mini USB socket without changing cables on the NetBox.

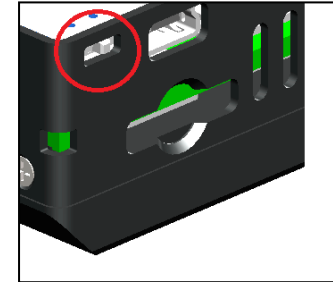

Mode switch (S1/ S2)

Beside the VGA-socket you will find a switch for TV_{out}. For the TV_{out} mode please use the supplied TV_{out} adapter cable. You can connect the cinch plug directly to a control monitor with CVBS (PAL) input (common name: Video In).

Please connect at first the respective cable (VGA or TV_{out} adapter cable) and then turn the switch in the appropriate position.

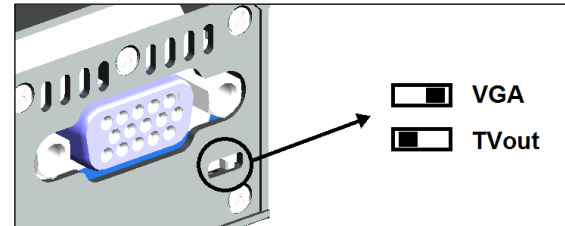

VGA/ TV_{out} switch

Remote Access to the NetBox

For settings on the NetBox you can connect a keyboard and a mouse to the available USB sockets as well as a monitor to the VGA socket (or a TV monitor via the TV_{out} adapter cable).

► Stand-alone Operation

Another very simple way are remote control software, for example remote desktop (RDP) which is available on each Windows system or **Ultra VNC** which you will find on your software CD. After installation you can have access to the NetBox either from a PC directly connected over an Ethernet cable or from a PC which is located anywhere and connected to the same network. Also remote connection via the internet is possible.¹⁾ To install Ultra VNC on your PC please start **install.bat** which is located on your PICconnect-CD in the folder **PI NetBox**. After installation you will find the following short cuts on your desktop:

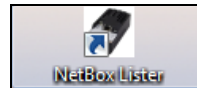

Please use the short cut **PI-NetBox UVNC** for access to a NetBox which is directly connected to your PC over an Ethernet cable. After starting the UVNC viewer using this shortcut you should see immediately a window which shows the screen of the NetBox.

Please use the short cut **UltraVNC Viewer** for access to a NetBox inside your network. After starting UVNC using this short cut you should see at first the following screen:

¹⁾ For remote access from outside to a NetBox connected to a company network please ask your system administrator for possibly necessary settings.

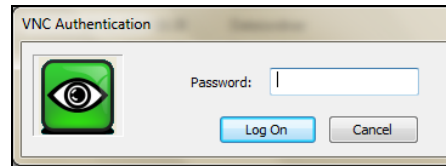
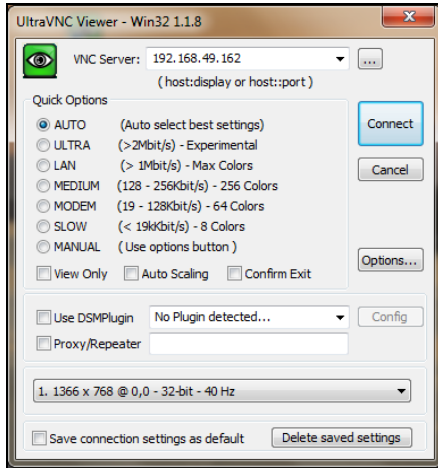

UltraVNC viewer setup

After input of the IP address of the NetBox, which in this case comes from a DHCP ¹⁾ server, please press **Connect**. In the following screen you have to enter the password **Remote** and after this press **Log On**. Now you should see the screen of the NetBox.

In chapter ► **Ethernet Network Communication** you will find an explanation how to figure out the IP address of the NetBox.

With the UltraVNC Viewer it is possible to have *simultaneous* access to one NetBox from different PCs inside a network.

¹⁾ DHCP – **D**ynamic **H**ost **C**onfiguration **P**rotocol: allows the automatic integration of a computer into an existing network.

With **NetBox Lister** you can start a tool which will list all NetBoxes located in your network or directly connected to your PC. With this tool you can also do a time synchronization. You can scan either the whole network or a certain IP address range. The filter function allows a selective search for NetBoxes only. If you press one of the **sync** buttons you can synchronize all NetBoxes simultaneously or a previously selected one with the system time of your local PC (where NetBox Lister is running).

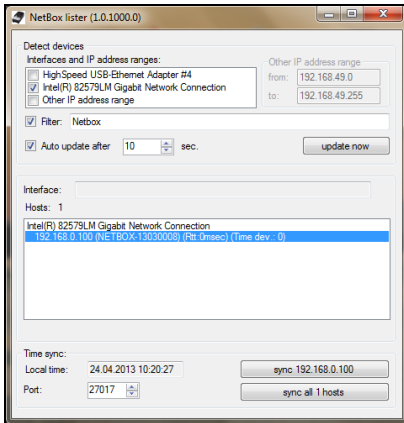

The NetBox is factory default set to Central European Time (CET or CEST). Depending on the time zone setting of your local PC time differences after synchronizations are possible. In this case you have to change the time zone settings on the NetBox.

► **System time**

The short cut **NetBox Maintain** is synchronizing the time automatically with a directly connected NetBox and is starting then automatically the UltraVNC viewer.

Applications and Start Options

On the Desktop of the NetBox you will find the following short cuts:



Application Start Config
Application Start Manager

starts the configuration dialog (**Config Server**)
starts the program selected in the configuration dialog

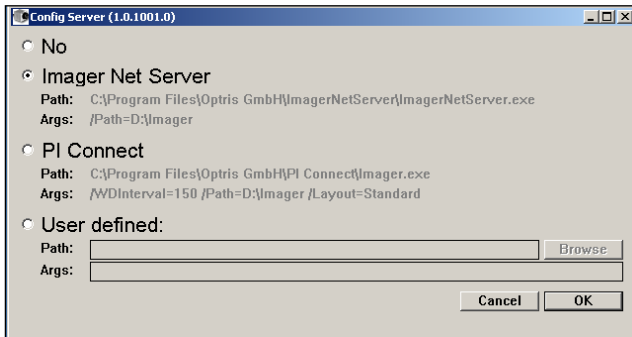

In the configuration dialog you can select programs which start automatically after booting the NetBox:

No
Imager Net Server

no automatic program start
automatic start of the server
application

PI Connect

automatic start of the
PI Connect

User defined

user defined start of one of
the both programs above

The factory default setting of the NetBox starts the **Imager Net Server** application after booting the system. This program is needed for the operation modes:

- Converter USB – Ethernet with direct connection to a PC (point-to-point connection)
- Converter USB – Ethernet with connection of a PC via a network or via the internet

For the Stand-alone operation with an IR camera please start **Application Start Config** and then select **PI Connect**.

In case you would like to start PI Connect or Imager Net Server with changed command line parameters [Args] please select **User defined**.

Example

The following configuration starts the PIConnect in the full screen mode:

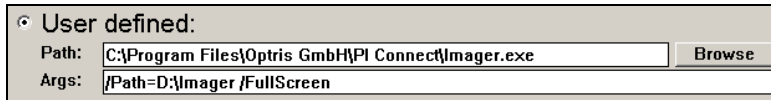

◦ User defined:

Path:

Args:

The start options selected in the configuration dialog are saved automatically in the NetBox and are available after a restart.

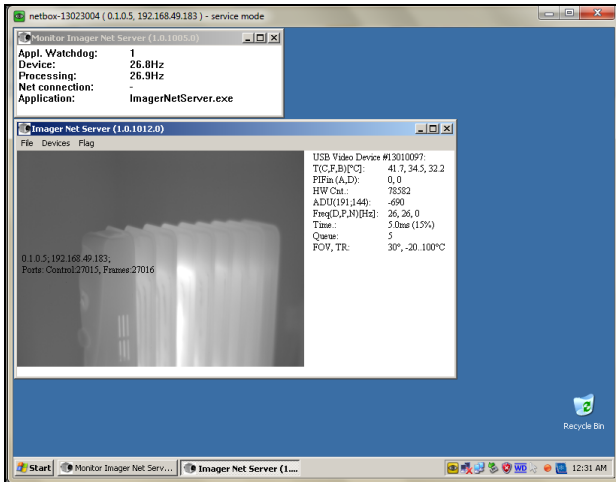

Screen of the NetBox – Imager Net Server

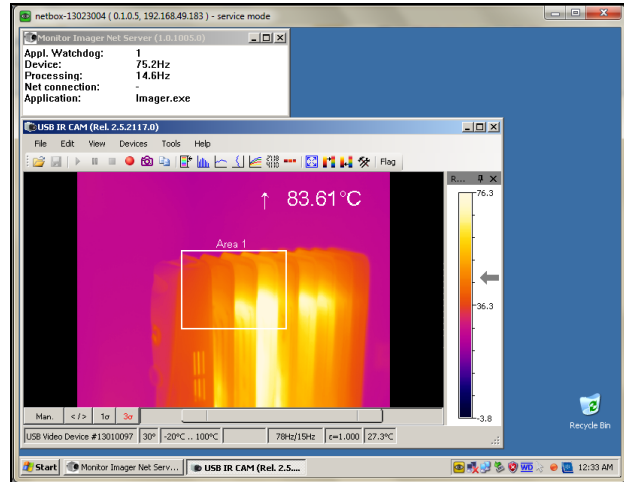

Screen of the NetBox – PI Connect

If an imager is connected to the NetBox you should see two active applications:
Monitor Imager Net Server and Imager Net Server or PI Connect.

Appl. Watchdog Device	Counter for the application monitoring function
Processing:	Device frequency
Net connection	Processing frequency
Monitor	Network frequency
Application	Display mode (VGA or TV-Out)
	monitored software application

Information in the *Monitor Imager Net Server* – application window

Menu	File	exit of the program	
	Devices	shows the connected imager	
	Flag	manual operation of the camera flag	
USB-Videogerät		Serial number of the connected imager device	
T (C, F, B)		Device temperatures (°C): C: FPA-Chip	
		F: Flag temperature	
		B: Housing temperature	
PIFin (A, D)		Status of the PIF input:	A: Analog IN (AI)
			D: Digital IN (DI)
HW Cnt.		Hardware-Counter (frame counter)	
ADU (192, 144)		ADU value of the center pixel (e.g. 192, 144 at PI4xx)	
Freq (D, P, N)		Frequency (Hz):	D: Device/ P: Processing/ N: Network
Time		Time per single frame	
Queue		Number of frames in network queue	
FOV, TR		Field of view (horizontal) of the imager lens, Temperature range	

Information in the *Imager Net Server* – application window

Watchdog

If, for any reason, the main software application (**Imager Net Server** or **PIConnect**) does not work properly (software hang-up or crash) or if the main application will be closed, the monitoring application (**Monitor Imager Net Server**) is restarting the program automatically.

In addition also the Windows operating system is monitored permanently by a watchdog application – you see the symbol **[WD]** in the right part of the task bar:



If the watchdog is recognizing a system error or problem it will restart the NetBox automatically. If you click with the right mouse button on this symbol you can open the watchdog window:



Beside a status information and internal set parameters you can see the elapsed time since you started the NetBox and also the elapsed time of the operation period before the last restart. The number of restarts can be reset (right mouse button on WD symbol – **Reset counter**).

Please note that all restarts (also not by the Watchdog initialized ones) will be counted here.

Autostart

In the Windows Autostart folder of the NetBox the following shortcuts are set default:

ewfMonitor

MouseHider

Watchdog

Application Start Manager

Write protection filter

hides the mouse pointer after 10s of inactivity

starts the Watchdog application

starts the program which was selected in Application Start Config

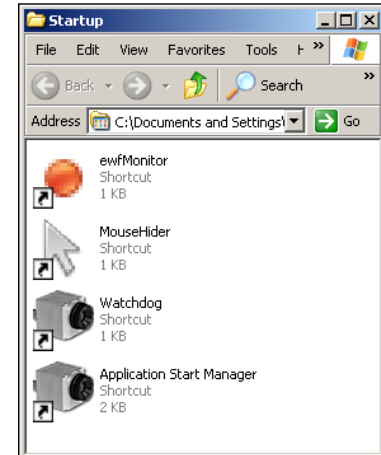

File transfer between NetBox and PC

To exchange files between the NetBox and a directly connected or in the network located PC please move the cursor to the title bar of the **UltraVNC Viewer** window and press the right mouse button. Start **File Transfer**. Alternatively you can also press the following button in the tool bar:



In the following explorer window you see on the left side your local PC (LOCAL MACHINE) and on the right side the NetBox (REMOTE MACHINE). Now you can copy files between both computers via the network link by marking them and pressing **Send** or **Receive**.

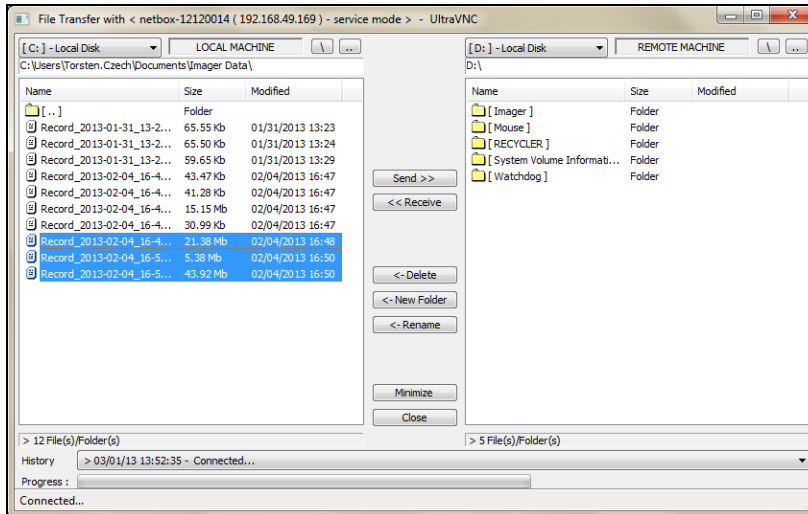

Ethernet Direct Communication

Please connect your imager with the supplied USB connection cable with the NetBox. Please connect your PC with an Ethernet cable with the NetBox. Now connect the power supply to the NetBox and to the mains. The NetBox will start to boot the system and should be ready to use after 2-3 minutes. You can check the status with the LEDs. At proper functioning now L1 and L5 should light up.

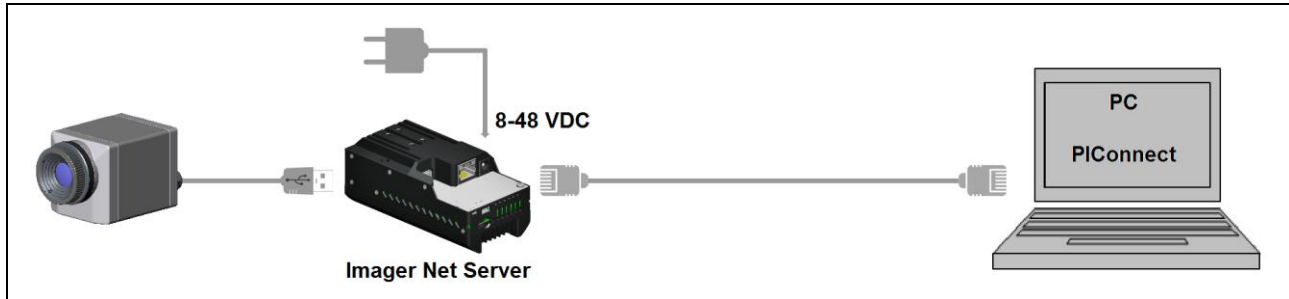

Ethernet direct connection (point-to-point connection)/ NetBox powered via power supply

If you use a PoE injector the power supply for the NetBox is not needed. In this case please connect the PoE injector as shown in the drawing below. At proper functioning now L1, L2 and L5 should light up.

The used Ethernet cables should be at least category 5 cables (Cat-5 according ISO/IEC 11801).

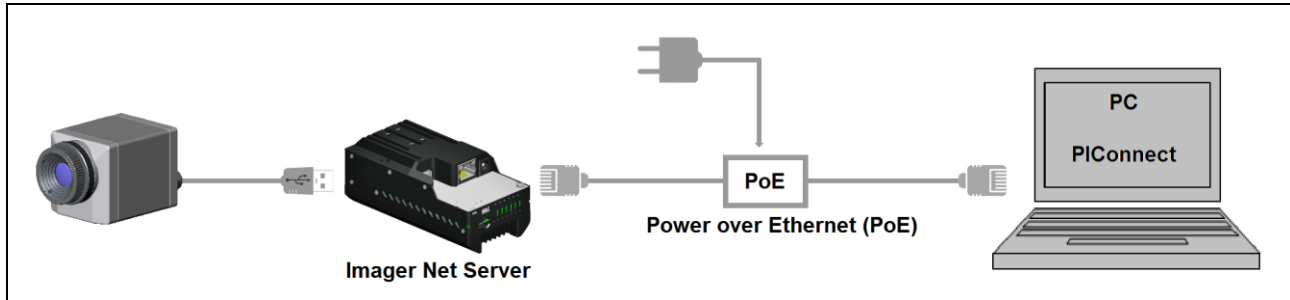

Ethernet direct connection (point-to-point connection)/ NetBox powered via PoE injector

Connection to the NetBox

The communication with the NetBox is done via the TCP/ IP protocol (Transmission Control Protocol/ Internet Protocol). The NetBox can get its IP address (Internet Protocol address) either from a DHCP server or it can work with a fixed IP address.

On a direct connection to a PC both, the NetBox as well as the PC must use a fixed IP address because no DHCP server is available here. The NetBox is using in this case the IP address **192.168.0.100**. On your PC you have to do the following settings once (depending on the operating system the procedure can differ from the here shown – the following description refers to a Windows 7 system).

1. Go to **System controls**; open **Network and Sharing Center**.

2. If you have an existing connection to a network (company network e.g.) you should see the following information:

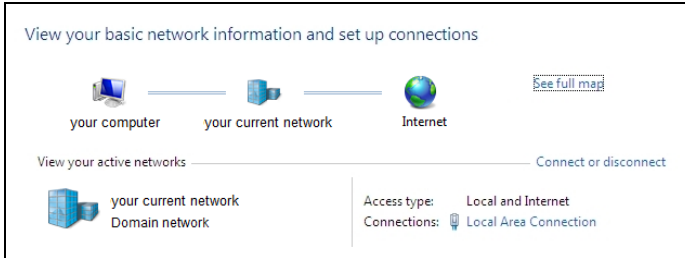

If your PC is not connected to any network, please go to **Change adapter settings** after you opened the **Network and Sharing Center**. Now go to **Local Area Connection**, right mouse button: **Properties**.
[continue at item 4]

3. Go to **Local Area Connection** – a status screen according [1] will be shown. Then go to **Properties**.

4. In the following window [2] mark **Internet protocol Version 4 (TCP/IPv4)** and go again to **Properties**.

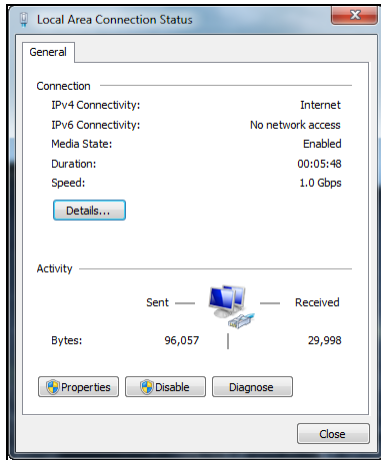

[1]

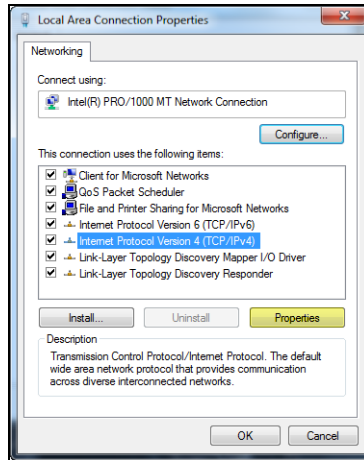

[2]

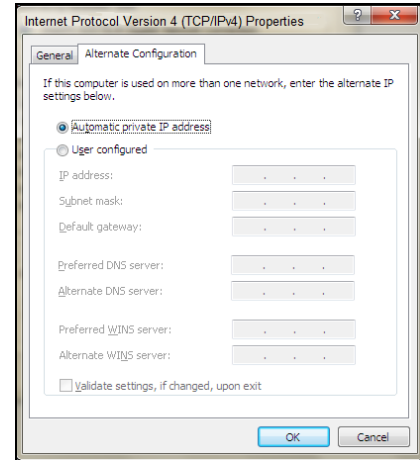

[3]

5. Please open now in window [3] the register **Alternate Configuration** and activate the checkbox **User configured**.

6. Now you can enter a user defined IP address for your PC. Please take care that the network part of the address has to be identical with the network part of the IP address of the NetBox, thus **192.168.0**. For the host part you have to use an address which is different from the one of the NetBox (100), so you may use 1 for example.

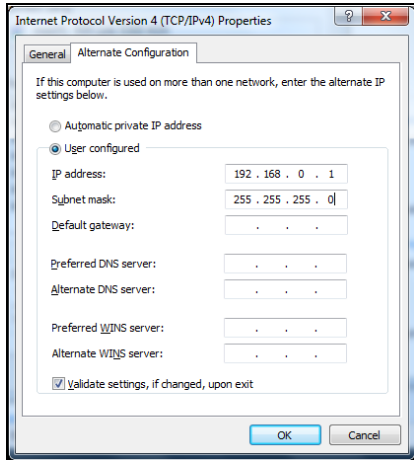

After you have made these settings and connected your PC with the NetBox using an Ethernet cable your PC will establish a point-to-point connection. This procedure can take several minutes.
In the **Network and Sharing Center** your network will now be shown up as a *non-identified network*.

Please start now the PIConnect on your PC and open the menu item **Tools/ Extended/ Remote devices....**
In the window which is appearing you should set a hook on **Enable** and enter the IP address of the NetBox (**192.168.0.100**). Press OK. The software will establish a connection to the remote device (imager) automatically.

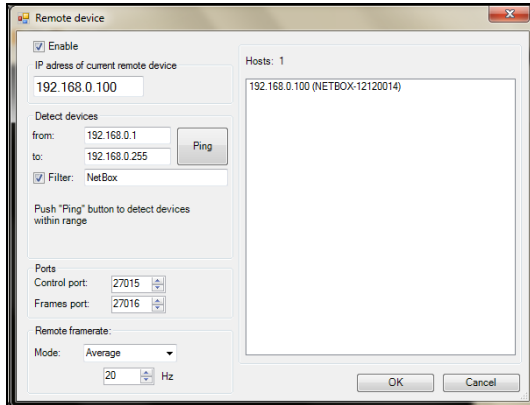

Search for network devices in PICConnect

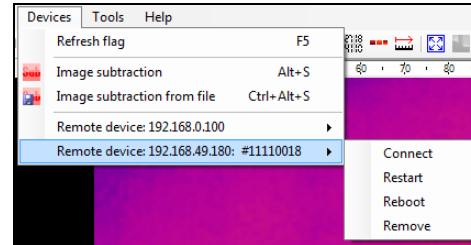

Device selection in PICConnect

Under **Remote framerate** you can enter the desired frame rate which should be transmitted via the network. Under the menu item **Devices** the imager which is connected to the NetBox shows up now. The following functions can be selected here:

- | | |
|----------------|---|
| Connect | manual connection with the remote device |
| Restart | restart of the Imager Net Server application on the NetBox |
| Reboot | reboot of the NetBox |
| Remove | remove of the device entry in this menu |

If the used imager is connected for the first time to the NetBox the following message appears:

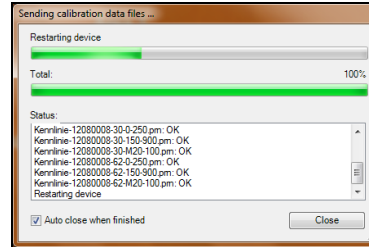
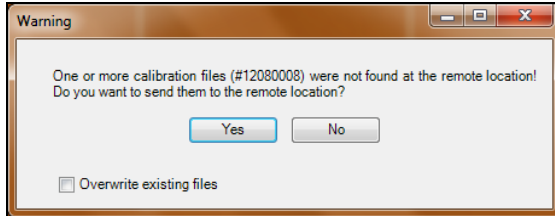

Please confirm with **Yes**. The calibration files will be transferred automatically from your PC to the NetBox and stored there. Now you should see the live picture from the imager on your PC. Alternatively you can copy the calibration data also manually via an USB stick into the NetBox folder **D:\Imager\Cali**.

Ethernet Network Communication

Please connect your imager with the supplied USB connection cable with the NetBox. Please connect the Ethernet connection of the NetBox with a network or internet (via a router e.g.). Now connect the power supply to the NetBox and to the mains. The NetBox will start to boot the system and should be ready to use after 2-3 minutes.

You can check the status with the LEDs. At proper functioning now L1 and L5 should light up.

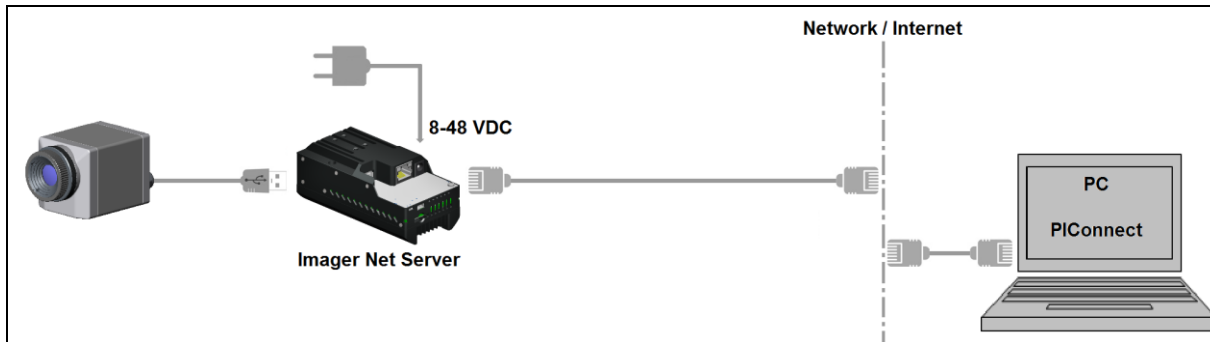

Ethernet network connection/ NetBox powered via power supply

If you use a PoE injector the power supply for the NetBox is not needed. In this case please connect the PoE injector as shown in the drawing below. At proper functioning now L1, L2 and L5 should light up.

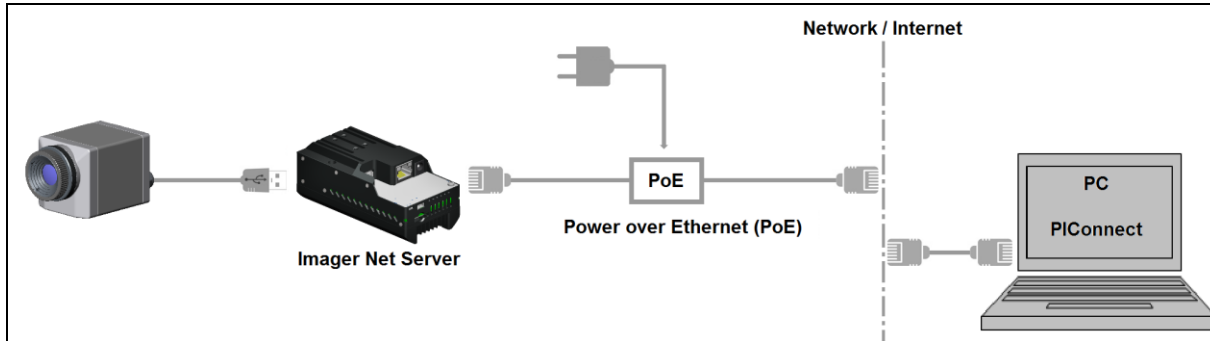

Ethernet network connection/ NetBox powered via PoE injector

If the NetBox is used in a network it gets its IP address from a DHCP server. In order to find the NetBox in the PIconnect of your local PC the address range of the local network must be known.

For this purpose please start the program **NetBox Lister**.

► Remote Access to the NetBox

Please start now the PIconnect on your local PC and open the menu **Tools/ Extended/ Remote devices....** In the window which opens set a hook on **Enable** and enter the address range of your local network under **Detect devices**. The fourth block should have the range **0 to 255**. If you now press **Ping** all computers inside the selected address range will be shown.

Under **Remote framerate** you can enter the desired frame rate which should be transmitted via the network.

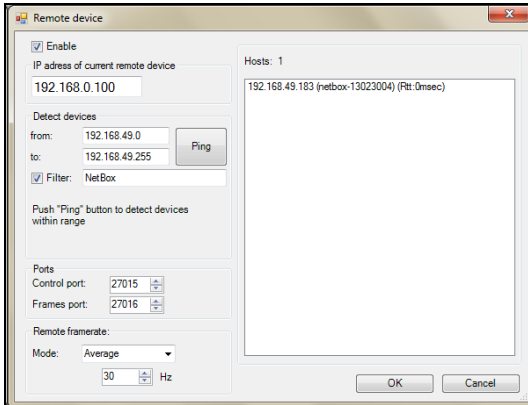

For a faster search you should activate the **filter** and enter *NetBox*. Now only computers with *NetBox* in their name will be shown.

Under **Hosts** you should see now your NetBox. Please mark this and press **OK**.

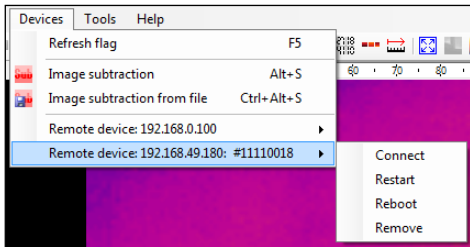

Under the menu item **Devices** the imager which is connected to the NetBox shows up now. The following functions can be selected here:

- | | |
|----------------|---|
| Connect | manual connection with the remote device |
| Restart | restart of the Imager Net Server application on the NetBox |
| Reboot | reboot of the NetBox |
| Remove | remove of the device entry in this menu |

If the used imager is connected for the first time to the NetBox the following message appears:

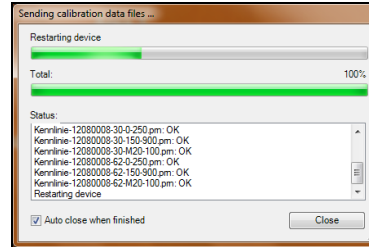
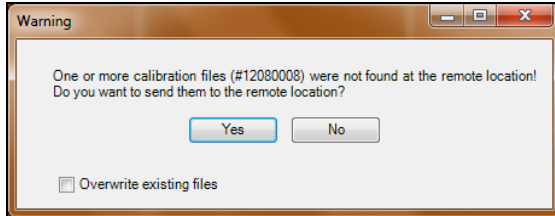

Please confirm with **Yes**. The calibration files will be transferred automatically from your PC to the NetBox and stored there. Now you should see the live picture from the imager on your PC. Alternatively you can copy the calibration data also manually via an USB stick into the NetBox folder **D:\Imager\Cali**.

Stand-alone Operation

As a stand-alone PC the NetBox can expand a IR camera to a separate system. For this operation mode you should connect a VGA or TV monitor and a USB keyboard to the NetBox. In addition the system can also be controlled via a remote access over an Ethernet connection.

▶ Remote Access to the NetBox

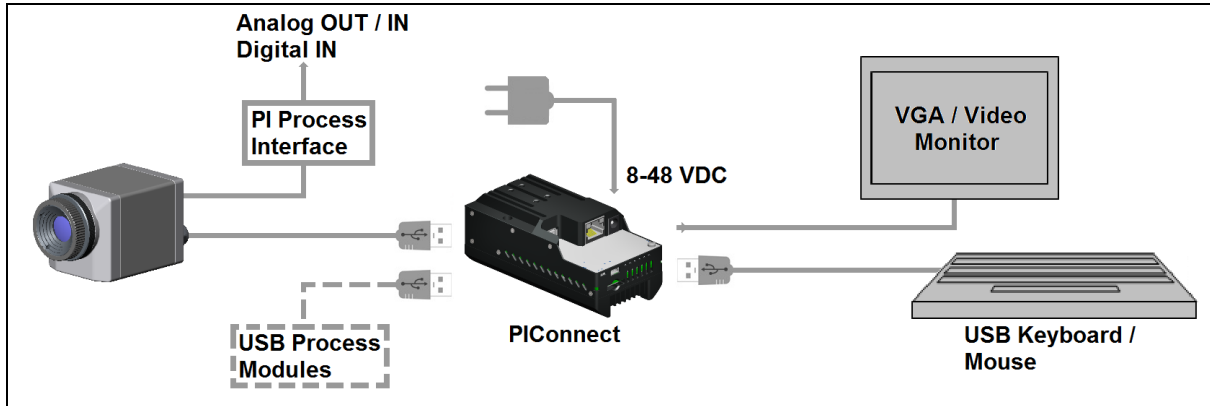

Stand-alone operation/ NetBox powered via power supply

After booting the NetBox the first time you will see the **Imager Net Server** application. Please close the monitor program and change it to **PI Connect** in the configuration dialog (Application Start Config).

▶ Operation/ Applications and Start Options

USB Driver

The USB-IR-camera as well as USB sticks, USB keyboards or USB mouses don't need a special device driver. System messages to new installed USB hardware devices are therefore suppressed to ensure a most comfortable use of the NetBox with the recommended standard components.

If you connect other USB devices which need a specific driver installation it might be necessary to start the installation process manually in the device manager.

System time

The NetBox does not contain a CMOS battery which is normally used for keeping the system time if the computer is switched off. On the NetBox therefore the current time will be saved regularly during operation. On a restart of the NetBox the system time is proceeding automatically starting at the last saved time. With this you have a chronology of imager recordings which use an automatic file name generation.

If the NetBox has a connection to the internet, the current time will be synchronized automatically via an internet time server after a certain period.

A manual time synchronization can be done with the tools **NetBox Maintain** und **NetBox Lister** from a PC which is directly or via network connected.

► Remote Access to the NetBox

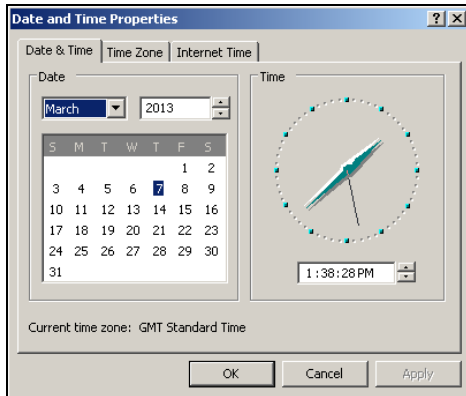

You can change the set time zone in the tab **Time Zone**.

To save the new setting permanently you have to deactivate the ► **Write Protection Filter** temporarily.

Write Protection Filter

The NetBox has a factory pre-installed write protection filter. This filter is protecting reliably the operating system and the complete drive C and allows a switch-off of the device without a shut down of the operating system.

The write protection filter (ewfMonitor) can be seen as shortcut in the start menu and as symbol in the task bar.

The colors have the following meaning:



red dot: **safe mode**



green dot: **write mode**

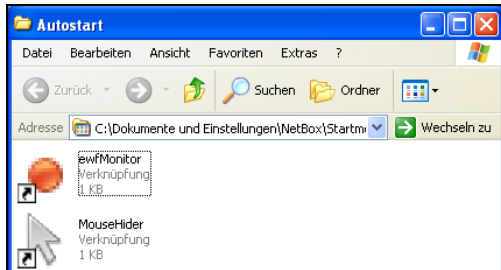

The NetBox should be used only with an activated write protection filter [red dot].

Write protection filter as short cut in folder Autostart

To save changed settings or if you want to install additional software the write protection has to be deactivated temporarily. To do this please move the cursor to the red dot in the task bar and push the right mouse button:

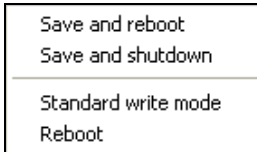

You can select between four different actions:

Save and reboot	Changes will be saved + Restart
Save and shutdown	Changes will be saved + shut down
Standard write mode	Switch into the write mode (green dot)
Reboot	Restart without saving of changes

The SSD drive of the NetBox has by factory default two partitions. The write protection refers to partition C only. On the partition D you can save application data. On drive D also the calibration data of the infrared imager are stored.

System Recovery

In case a recovery of the Windows operating system of the NetBox is necessary you should use the supplied USB recovery stick. Follow the steps described hereafter. **Do not disconnect power from the NetBox during the recovery procedure.**

After the system recovery the NetBox has the factory default settings. All data which was stored before on the SSD will get lost.

Step 1:

Please connect a VGA monitor and a USB keyboard with the NetBox. Connect the USB recovery stick to a free USB port and switch on the NetBox. If you see the following start screen please press the **ESC** button for at least **2 seconds** (keep pressed).

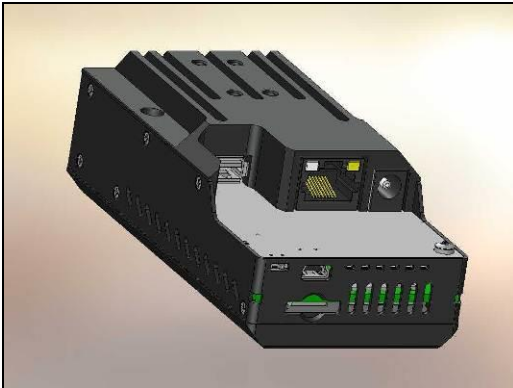

Start screen of the NetBox

Step 3:

After the complete system recovery the NetBox will be automatically shut down and switched off (all LEDs are off). Now you should disconnect for a short time the power (disconnect the power supply). After reconnecting power and booting of the system you should see the following message:

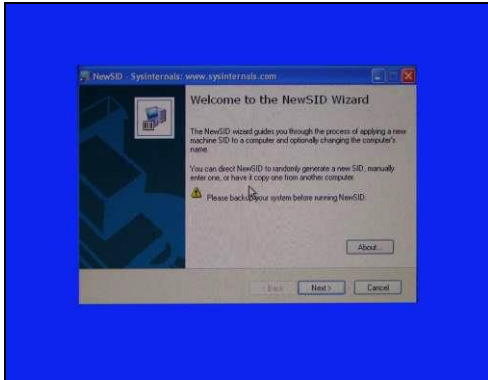

Please press **Next**

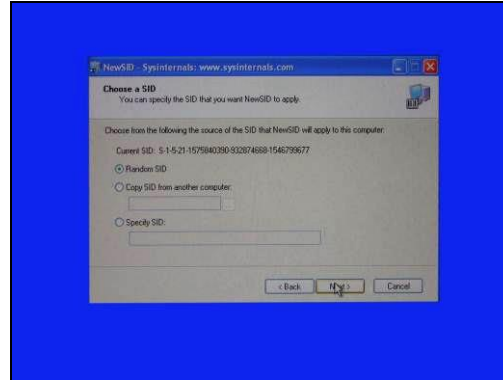

Select **Random SID** and then **Next**

Step 4:

In the next window you can rename the NetBox (optional). Please note that the new name should have at maximum 15 characters.

Press two times **Next**. Now the system will be shut down again.

Your NetBox is now ready for use again.



Rename the NetBox (optional)

