

MAINSBOOST

Mainsboost Installation, Operation & Maintenance Instructions

Please leave this instruction booklet with the home owner as it contains important guarantee, maintenance and safety information



Read this manual carefully before commencing installation.

This manual covers all Mainsboost vessels for vertical and horizontal and units.



PRODUCT DESCRIPTION

Mainsboost consists of one key assembly, the Mainsboost vessel complete with upstream line-in kit.

APPLICATION

Mainsboost is designed to offer stored clean, potable cold water under pressure for all domestic or small commercial applications where mains water is insufficient to offer consistent and reliable water services.

Installation parameters must not exceed the values given in the technical specifications.

STORAGE

If this product is not to be installed immediately on receipt, ensure that it is stored in a dry, frost and vibration free location in its original packaging.

CONTENTS

	Page
Checklist3
Introduction4
Important Facts – read before commencing installation5
Location6
Terminology7
Configuration8
Installation10
Commissioning14
Technical Specification15
Trouble Shooting16
Guarantee17

WARNINGS:



- **Mainsboost system must not be used for any other application without the written consent of Stuart Turner Limited.**
- **This appliance can be used by children aged from 8 years and above and persons with reduced physical, sensory or mental capabilities or lack of experience and knowledge if they have been given supervision or instruction concerning use of the appliance in a safe way and understand the hazards involved.**
- **Children shall not play with the appliance.**
- **Cleaning and user maintenance shall not be made by children without supervision.**
- **Ensure the floor is sufficiently strong enough to take the total weight of the unit when full of water (see Technical Specification section). Take care when manoeuvring the unit so as not to damage it.**
- **Ensure the unit is fixed to the floor using suitable fixings to avoid risk of toppling over.**
- **To prevent personal injury, ensure all water pressure is released from the pressure system prior to work being performed. Ensure pumps are disconnected and/or electrically isolated.**
- **It is strongly recommended that the system is protected by a suitable pressure relief valve set at or below the maximum tank pressure rating. Failure to install a pressure relief valve may result in tank explosion in the event of a system malfunction or over pressurization, resulting in property damage, serious personal injury or death.**
- **If the pressure tank leaks or shows signs of corrosion or damage do not use it.**

Please read installation details carefully as they are intended to ensure this product provides long, trouble free service. Failure to install the unit in accordance with the installation instructions will lead to invalidation of the warranty. These instructions must be left with the product.

CHECKLIST

IMPORTANT: Your Mainsboost water performance system will be delivered in a minimum of two boxes on one pallet. Please check the contents within 24 hours of receipt and if any component is damaged, please contact Stuart Turner Ltd immediately.

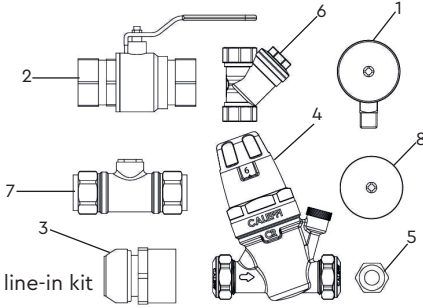

Package 1
Upstream line-in kit
Fig. 1

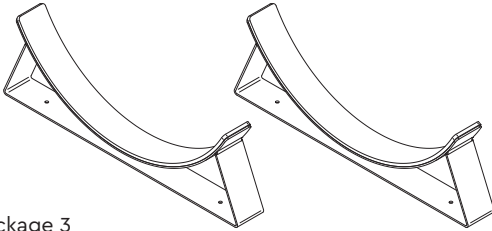

Package 3
Cradle
(only applicable for horizontal installations with
MB 200SH or MB 250SH models)
Fig. 3

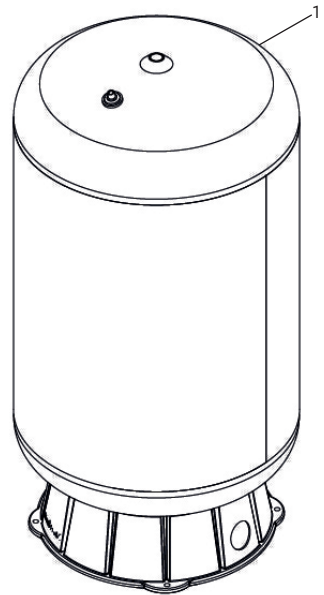

Package 2
Mainsboost vessel
Fig. 2

Item	Description	Qty	Item	Description	Qty		
Package 1	1	¼ " BSP pressure gauge	2	Package 2	1	Mainsboost vessel	1
	2	Lever isolating ball valve	1				
	3	Pressure vessel connector fitting	1	Package 3	1	Cradle	2
	4	6 bar pressure regulating valve	1				
	5	¼ x ½ " BSP Brass bush	1				
	6	Y pattern inline strainer	1				
	7	Double check valve	1				
	8	¼ " BSP Pressure gauge	1				

Your product may vary slightly from the picture above.

Cont ...

1 INTRODUCTION

1.1 Congratulations on buying a Mainsboost system, designed to offer consistent and reliable water services throughout the property and the only system available that is patent protected No. GB2349908.

1.2 **Patents, Trademarks & Trade Names:**
'Mainsboost' 'Mainsboost Plus™' and 'Mainsboost Charger' are registered Trademarks of Stuart Turner Ltd.

The use of this system is patent protected and the Mainsboost vessel cannot be mixed with other accumulator systems without prior approval from Stuart Turner Ltd.

The Mainsboost vessels have special characteristics and the use of other vessels in this application could prove to be detrimental to the design and performance of the system and the patent.

Stuart Turner Ltd will treat any infringement of the patent very seriously and therefore recommend that any questions regarding application be brought to the company for consideration.

1.3 **How the Mainsboost System works:**

The Mainsboost vessel stores water from the rising main in a sealed water chamber, separated from the air space by a rubber diaphragm and pressurised to an optimum setting. When water is drawn off by downstream services, the water from the mains is supplemented by the water from the Mainsboost unit to provide a balanced supply at consistent pressure to downstream services.

2 IMPORTANT FACTS READ BEFORE COMMENCING INSTALLATION

A Water temperature

This unit is designed for cold water applications only which should not exceed the following values:

- 2.11 The maximum allowable water temperature is 35 °C.
- 2.12 The minimum allowable water temperature is 4 °C.

B Pipework – General

- 2.13 **Secure pipework:** Ensure pipework to and from the Mainsboost is independently supported & clipped to prevent forces being transferred.
- 2.14 **Flux:** Solder joints must be completed and flux residues removed prior to completing the installation (**flux damage will void any warranty**).
- 2.15 **Pipework design:** Care should be taken in the design of pipework runs to minimize the risk of air locks e.g. use drawn bends rather than 90° bends.

C Plumbing Installation Regulations

- 2.16 The plumbing installation must comply with the current water and building regulations.
- 2.17 The plumbing installation must be installed by a qualified person.

D Mainsboost vessel

- 2.18 Ensure the Mainsboost vessel is installed correctly before operating the unit, to avoid damage.



Do not attempt to dismantle the Mainsboost vessel

The Mainsboost vessel is pressurised to a pre-set level at the factory see Section 7.11 – Commissioning for details.

3 LOCATION – GENERAL



3.11 **Access:** For emergencies and maintenance the Mainsboost must be easily accessible.

3.12 **Protection:** The system must be located in a dry position, and protected from freezing. Avoid environments which have a high ambient temperature, high humidity or excessive condensation and salt damage, etc.

3.13 **Incoming mains water pressure:** The incoming water pressure of at least 1.5 bar is required and should not exceed 5 bar.

3.14 Ensure that location of the unit allows adequate space to give reasonable access to all parts to accommodate service/commissioning.

3.15 **Pipework:** Pipework should be sized to ensure optimum performance of the system.

3.16 **Direction of flow:** See Fig. 4 to identify the suction and discharge connections.

4 TERMINOLOGY

4.11 System Designation:

It is important to understand what upstream and downstream refers to before starting the installation.

4.12 Upstream

The term 'Upstream' refers to the system configuration from the consumer's stopcock to the point where the supply reaches the inlet port of the Mainsboost vessel.

4.13 Downstream

The term 'Downstream' refers to the system configuration from the outlet tapping on the Mainsboost vessel, along the distribution header (if configured in this way) and into the distribution pipework and outlets. This includes hot and cold services where both are present (see Fig. 4).

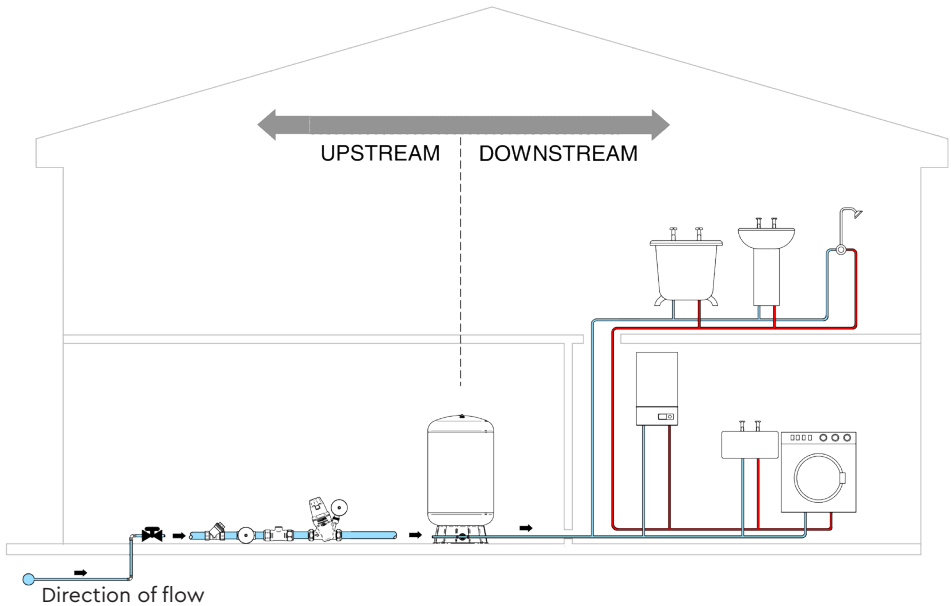

Fig. 4 System designation

5 CONFIGURATION

5.11 Mainsboost is a very flexible solution, offering a patent protected packaged system to suit any type or size of building no matter how large or small the demand is. The following illustrations depict just some of the most typical installations.

5.12 **Single occupancy application:**

Use of Mainsboost in a house offers water on demand whilst giving maximum flexibility. As can be seen the upstream line-in kit has to be fitted on to the rising main but the vessels can be fitted wherever there is a space, for example; utility, kitchen, upstairs cupboard or loft, providing adequate provisions are taken for the weight, frost protection etc (see Fig 5). Where height restrictions exist the MB 200SH and MB 250SH Mainsboost units can be supplied suitable for horizontal installation.

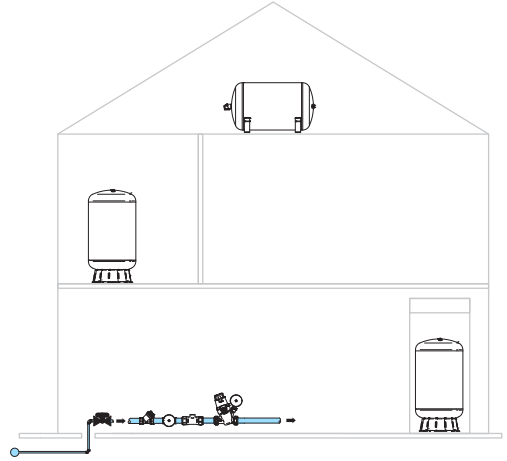

Fig. 5

5.13 **Multiple occupancy application:**

Often affected by poor water supplies Mainsboost offers the perfect solution. For multiple occupancy buildings again the upstream line-in kit is located next to the rising main and sized to meet the demand of the entire building. Each apartment then has its own vessel located within the property, sized to meet the apartments own demand (see Fig. 6).



Fig. 6

Cont ...

5.14 High demand single occupancy application:

Where single properties have a much higher demand, it may be necessary to use additional Mainsboost vessels connected in parallel to ensure sufficient water is on tap to meet the much higher demand. Fig. 7 shows all vessels being located in the same place.

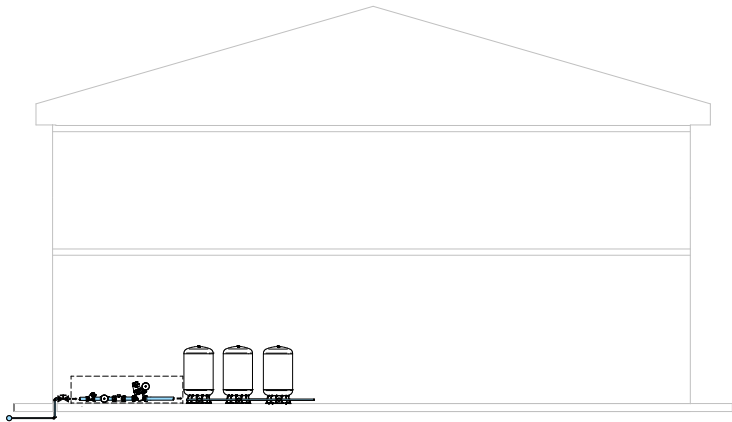

Fig. 7

5.15 Water softener:

Note: If a water softener is to be fitted it **must** be located between the upstream line-in kit and the vessel. If high pressure is also required to the drinking tap fit a Stuart Water Conditioner, available from Stuart Turner, rather than a water softener.

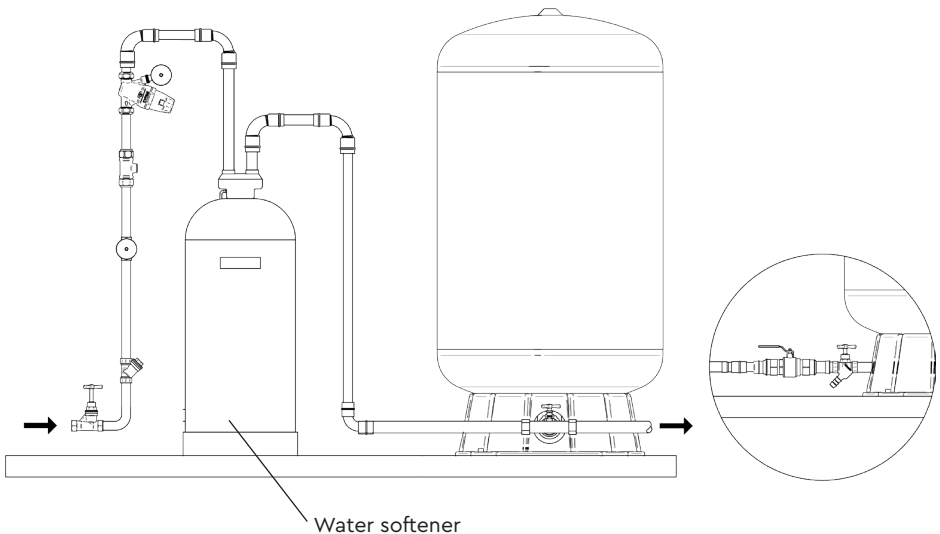

Fig. 8

Water softener

Cont ...

6 INSTALLATION

Step 1:

Remove the Mainsboost vessel from its packaging and check to ensure it is not damaged.



- **WARNING: depending on cylinder size this may require two people to complete safely.**
- **Ensure the floor is sufficiently strong enough to take the total weight of the unit when full of water (see Technical Specification section). Take care when manoeuvring the unit so as not to damage it.**

6.11 Vertically mounted Mainsboost vessels

- a) Carefully turn the vessel on its side using the discarded packaging to protect it.
- b) Once on its side screw the Mainsboost vessel connector (item 3) provided in the upstream line-in kit into the tank elbow at the base using suitable thread seal such as PTFE tape or liquid thread lock (see Fig. 9).
- c) Cut a piece of 28 mm dia. copper pipe to the following minimum length, ensuring clearance of the base.

Pipe length:

MB 100SV = 210 mm MB 200SV = 270 mm MB 300SV = 270 mm

MB 130SV = 210 mm MB 250SV = 270 mm MB 450SV = 340 mm

Then re-erect the cylinder.

- d) Fit the isolating valve provided to the tail now protruding from the base of the vessel.

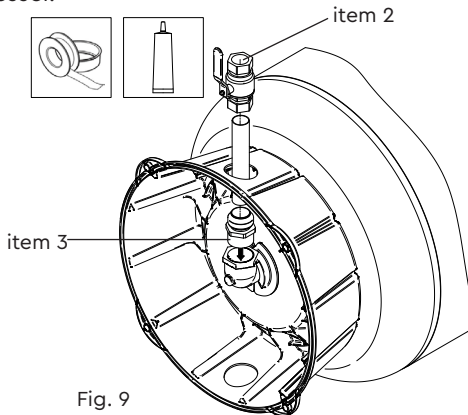

- e) The vessel assembly should then be positioned and checked to ensure there is sufficient space to install the upstream line-in kit between the stopcock and pressure vessel inlet. Refer to the chart (Fig. 17) as a guide.

- f) Fix the Mainsboost vessel securely to the floor using appropriately selected and sized fixings.

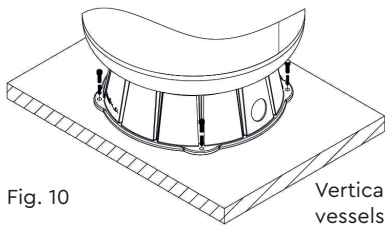

Fig. 10

Vertically mounted vessels

6.12 Horizontally mounted vessels

- a) Fix the two cradles in place where the unit is to be located in line with each other per chart shown below.

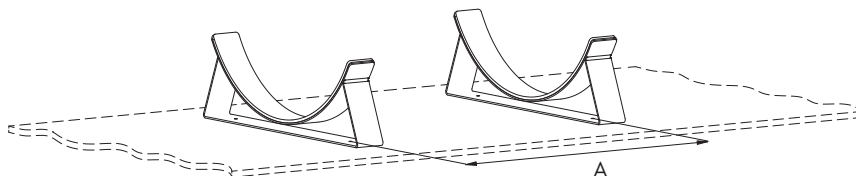

Fig. 11

Dimension between hole centres	
Tank size	A
200 litre	570 mm
250 litre	740 mm

- b) Position the cylinder centrally on the cradles with the outlet elbow facing upwards.

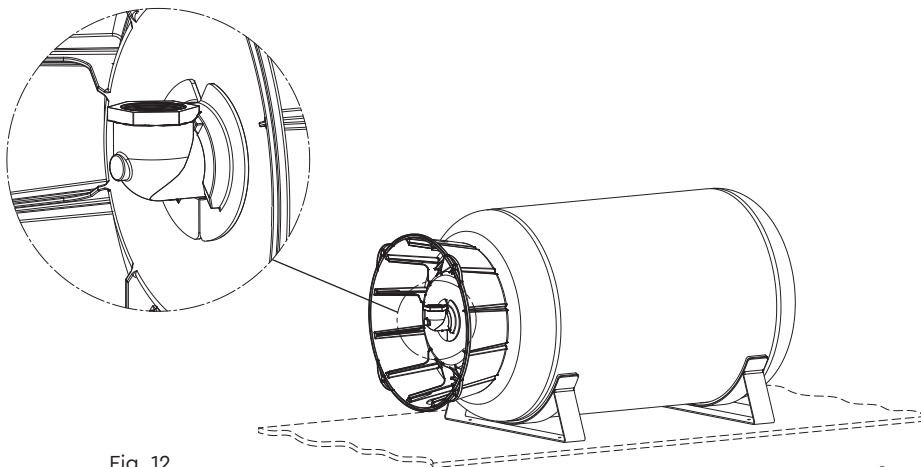
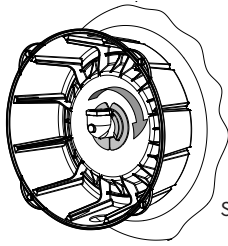

Fig. 12

Cont ...

c) Remove the plastic skirt by rotating anti-clockwise to unclip and discard.



Step 1: twist
Fig. 13

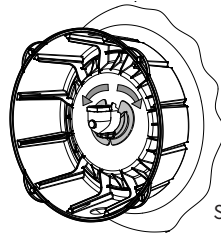

Step 2: unclip
Fig. 14

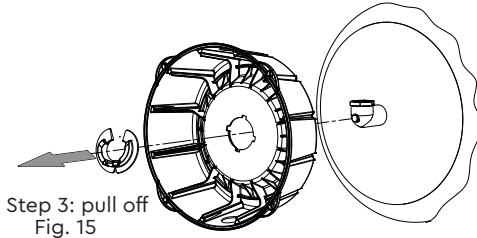

Step 3: pull off
Fig. 15

d) With the vessel on its side screw the Mainsboost vessel connector (item 3) provided in the upstream line-in kit, into the tank elbow using suitable thread seal such as PTFE tape or liquid thread lock (see Fig. 16).

e) Cut a piece of 28 mm dia. copper pipe to the following minimum length, ensuring clearance of the base.

Pipe length:

MB 100SV = 210 mm	MB 200SV = 270 mm	MB 300SV = 270 mm
MB 130SV = 210 mm	MB 250SV = 270 mm	MB 450SV = 340 mm

f) Fit the isolating valve provided to the tail.

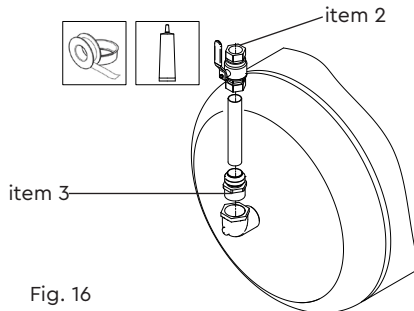

Fig. 16



Please note: Horizontal mounting is available for the steel MB 200 SH and MB 250 SH vessels only.

Note: **Do not** forget if a water softener is to be installed this has to be included in this pipe run, and additional space must be allocated for this.

Do not fit smaller pipework than the upstream line-in kit accepts as this will impair performance.

Cont ...

Step 2:

Upstream line-in kit

The upstream line-in kit includes:

- 1 – inline strainer
- 2 – pressure gauge (upstream)
- 3 – double check valve
- 4 – pressure reducing valve
- 5 – pressure gauge (fitted to pressure reducing valve)
- 6 – MainsBoost vessel connector (see step 1)

The above components must be installed in the correct order to ensure safe and satisfactory system operation.

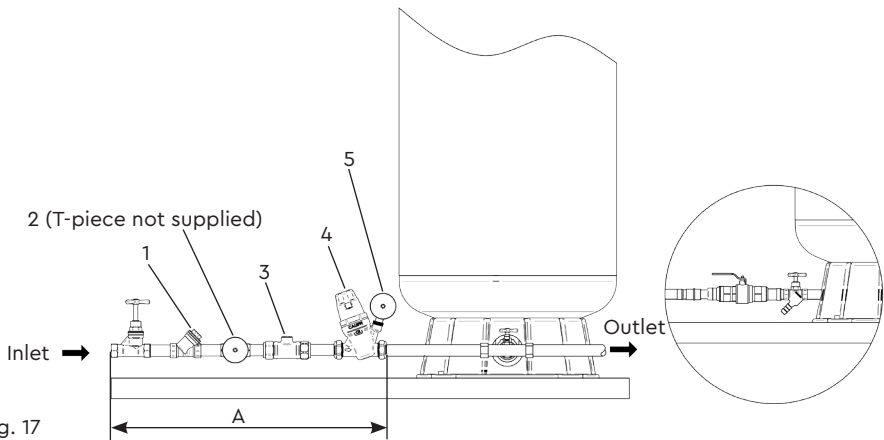

Fig. 17

Pipe Size	Minimum pipe length required to install the upstream line-in kit (mm) (A)
22 mm	480 mm
28 mm	580 mm
35 mm	630 mm
40 mm	735 mm
54 mm	820 mm

Completed installation

7 COMMISSIONING

7.11 Check vessel pre-charge pressure:

It is important to have the correct pre-charge pressure in the vessel for your site conditions to optimise performance. The vessel is supplied with a pre-charge pressure of approximately 1.4 bar (4.0 bar for MB 750SV, MB 1000SV, MB 1500SV & MB 2000SV models), and should **never** have a preset pressure of less than 0.5 bar.

Checking and adjustment to the vessel pre-charge air pressure can only be carried out when the vessel is empty (contains no water).

7.12 Check mains static pressure:

- Close outlets and check pressure gauge after 'Y' strainer – for static mains pressure and note it. This should be done at peak times of use.
- Turn stopcock off and leave outlet taps open.

7.13 Check the chart below for the correct vessel pressure against the static mains pressure recorded.

Static mains pressure	Set vessel pre-charge pressure to	Differential	Set PRV maximum setting to
bar	bar	bar	bar
1.5	0.55	1.0	2.0
2.0	0.55	1.5	2.5
2.5**	1.0	1.5	3.0*
3.0	1.5	1.5	3.5
3.5	2.0	1.5	4.0
4.0	2.5	1.5	4.5

*Adjust pressure regulating valve down to these settings where possible.

**Recommended setting.

Using a pressure gauge check the vessel and adjust to suit through the schrader valve.

Warning: Note PRV setting must not exceed 5.0 bar.

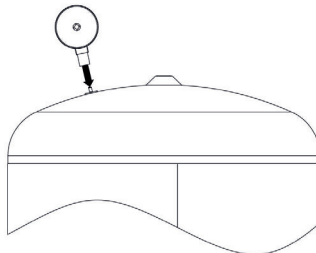

Fig. 18

7.14 On completion of the installation, follow the commissioning process below.

- **Leave** all outlet valves closed.
- Turn on stopcock and open inlet ballvalve, both pressure gauges on inlet and PRV will start to show movement as the mains pressure fills the system.
- Check for leaks on all joints made.
- The incoming mains pressure will start to fill the vessel with water.

The time taken to fill the vessel will vary depending on the vessel size and mains water pressure.

8 TECHNICAL SPECIFICATION

Mainsboost Vessel									
General	WRAS approval					1501305 / 1901372			
	Approvals					WRAS, CE			
	System patent no.					2349908			
	Guarantee					5 years			
Performance	Maximum working pressure*					1000 kPa (10 bar)			
	Min / Max operating temperature					Min 4 °C / Max 35 °C			
	Max rated temperature					90 °C			
Materials	Pressure vessel					Epoxy coated mild steel			
	Membrane					Butyl rubber			
Steel vessels vertical	Model	Vessel capacity (litres)**	Dimensions (mm)			Weight empty (Kg)	Weight filled (Kg)	Maximum weight (Kg)	ULK Kit (mm)
			H	W	D				
	MB 100SV	55	890	410	410	17.5	72.5	117.5	22
	MB 130SV	71	1100	410	410	21.5	92.5	151.5	22
	MB 200SV	110	1030	535	535	33.5	143.5	233.5	22
	MB 250SV	132	1210	535	535	38.5	170.5	288.5	22
	MB 300SV	174	1505	535	535	47	221	347	22
	MB 450SV	248	1545	660	660	72	320	522	22 or 28
	MB 750SV	413	1950	750	750	111	524	861	35
	MB 1000SV	550	2180	800	800	149	699	1149	35
MB 1500SV	825	2380	960	960	242	1067	1742	35	
MB 2000SV	1100	2520	1100	1100	370	1470	2370	35	
Steel vessels horizontal	MB 200SH	110	558	540	1026	38.5	148.5	238.5	22
	MB 250SH	132	558	540	1206	43.5	175.5	293.5	22

*Note: The maximum pressure that can be applied to the cylinder under any installation conditions.

**Note: At typical working pressure

Stuart Turner reserve the right to amend the specification in line with its policy of continuous development of its products.

9 TROUBLE SHOOTING GUIDE

Symptoms	Probable Cause	Recommended Action
Poor flow.	ISO valve not opened on pressure vessel. Filter blocked.	Check valve is fully open. Isolate system and clean out strainer.
Poor pressure.	Mains pressure dropped. PRV set incorrectly.	Check pressure gauge on supply (2) Fig. 17. If below 1.5 bar at peak times, recommend use of Mainsboost Plus pump. Check PRV. Gauge should read between 1.5 and 3.0 bar, adjust to suit. Note: Pressure gauge (2) reading has to exceed desired pressure on (4).
System works but runs out of water.	Insufficient vessel capacity.	Call Stuart Turner on +44 (0) 800 31 969 80

10 YOUR GUARANTEE

Congratulations on purchasing a Stuart Turner Mainsboost system.

We are confident this product will give you many years of trouble free service as all our products are manufactured to the very highest standard.

The Mainsboost benefits from a five year guarantee.

Within the guarantee period we will repair, free of charge, any defects in the Mainsboost resulting from faults in material or workmanship, repairing or exchanging the part affected or whole unit as we may reasonably decide.

Not covered by this guarantee: Damage arising from incorrect installation, improper use, unauthorised repair, normal wear and tear and defects which have a negligible effect on the value or operation of the unit.

Reasonable evidence must be supplied that the product has been purchased within the guarantee term prior to the date of claim (such as proof of purchase or the product serial number).

This guarantee is in addition to your statutory rights as a consumer. If you are in any doubt as to these rights, please contact your local Trading Standards Department.

In the event of a claim please telephone **'TechAssist'** customer support.

+44 (0) 800 31 969 80

You should obtain appropriate insurance cover for any loss or damage which is not covered by Stuart Turner Ltd in this provision.

Please record here for your records.

TYPE NO.	SERIAL NO.	DATE PURCHASED



DECLARATION OF CONFORMITY

Machinery Directive – 2006/42/EC

BS EN ISO 12100-1

Simple Pressure Vessel Directive – 2014/29/EU

IT IS HEREBY CERTIFIED THAT THE MAINSBOOST SYSTEM AS SERIAL NUMBER BELOW,
COMPLIES WITH THE ESSENTIAL REQUIREMENTS OF THE ABOVE E.E.C. DIRECTIVES.

[Empty dashed box for serial number]

RESPONSIBLE PERSON
AND MANUFACTURER

STUART TURNER LIMITED
HENLEY-ON-THAMES, OXFORDSHIRE
RG9 2AD ENGLAND.

Signed:  Engineering Manager

Stuart Turner are an approved company to BS EN ISO 9001:2015



Stuart Turner Ltd, Henley-on-Thames, Oxfordshire RG9 2AD ENGLAND

Tel: +44 (0) 1491 572655, Fax: +44 (0) 1491 573704

info@stuart-turner.co.uk www.stuart-turner.co.uk