

# MAINSBOOST

## Mainsboost Charger Installation, Operation & Maintenance Instructions

Please leave this instruction booklet with the home owner as it contains important guarantee, maintenance and safety information



**Read this manual carefully before commencing installation.**

This manual covers all Mainsboost Charger units.

**Mainsboost Charger Pump MBC 12 & Bypass Kit – Wall Mounted**



## PRODUCT DESCRIPTION

Mainsboost Charger MBC 12 pump assembly, consists of case, pump and connecting hoses.

## APPLICATION

Mainsboost Charger MBC 12 is designed to offer stored clean, potable cold water under pressure for all domestic or small commercial applications where mains water is insufficient to offer consistent and reliable water services.

**Installation parameters must not exceed the values given in the technical specifications.**

## STORAGE

If this product is not to be installed immediately on receipt, ensure that it is stored in a dry, frost and vibration free location in its original packaging.

## CONTENTS

|   | Page |
|---|------|
| Checklist .....   | 5    |
| Introduction .....  | 6    |
| Important Facts – read before commencing installation ..... | 7    |
| Location .....  | 8    |
| Terminology .....   | 9    |
| Installation .....  | 10   |
| Electrical .....  | 12   |
| Commissioning .....   | 14   |
| Technical Specification .....                               | 17   |
| Trouble Shooting .....                                      | 18   |
| Guarantee .....   | 19   |

## WARNINGS:



- **Mainsboost Charger MBC12 must not be used for any other application without the written consent of Stuart Turner Limited and in particular, must not be connected directly to the mains water supply.**
- **This appliance can be used by children aged from 8 years and above and persons with reduced physical, sensory or mental capabilities or lack of experience and knowledge if they have been given supervision or instruction concerning use of the appliance in a safe way and understand the hazards involved.**
- **Children shall not play with the appliance.**
- **Cleaning and user maintenance shall not be made by children without supervision.**
- **Maximum head (closed valve) 43 metres.**
- **The motor casing can become very hot under normal operating conditions. Care must be taken to ensure it cannot be touched during operation.**
- **The electrical installation must be carried out in accordance with the current national electrical regulations.**
- **The electrical installation must be installed by a qualified person.**
- **In the interests of electrical safety a 30 mA residual current device (R.C.D. not supplied) should be installed in the supply circuit. This may be part of a consumer unit or a separate unit.**
- **Before starting work on the electrical supply ensure power supply is isolated.**
- **DO NOT allow the supply cord to contact hot surfaces, including the motor shell, pump body or pipework. The cord should be safely routed and secured by cable clips.**

- **This appliance must be earthed via the supply cord, which must be correctly connected to the earth point located in the terminal box.**
- **The supply cord and internal wiring within the terminal box are routed and secured to ensure compliance with the electrical standard EN 60335-1. It is essential that prior to any disturbance of this internal wiring, all cable routing and securing details are carefully noted to ensure re-assembly to the same factory pattern is always maintained.**
- **If the supply cord is to be changed or is damaged, it must be replaced with a special cord assembly available from Stuart Turner or one of their approved repairers.**

**Please read installation details carefully as they are intended to ensure this product provides long, trouble free service. Failure to install the unit in accordance with the installation instructions will lead to invalidation of the warranty. These instructions must be left with the product.**

# CHECKLIST

**IMPORTANT: Your Mainsboost Charger MBC 12 water performance system will be delivered in two boxes. Please check the contents within 24 hours of receipt and if any component is damaged, please contact Stuart Turner Ltd immediately.**

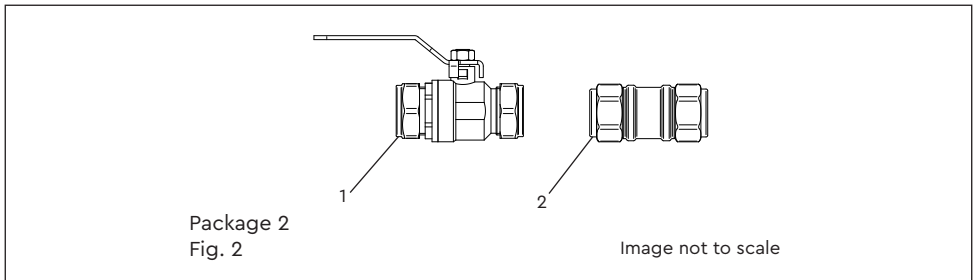
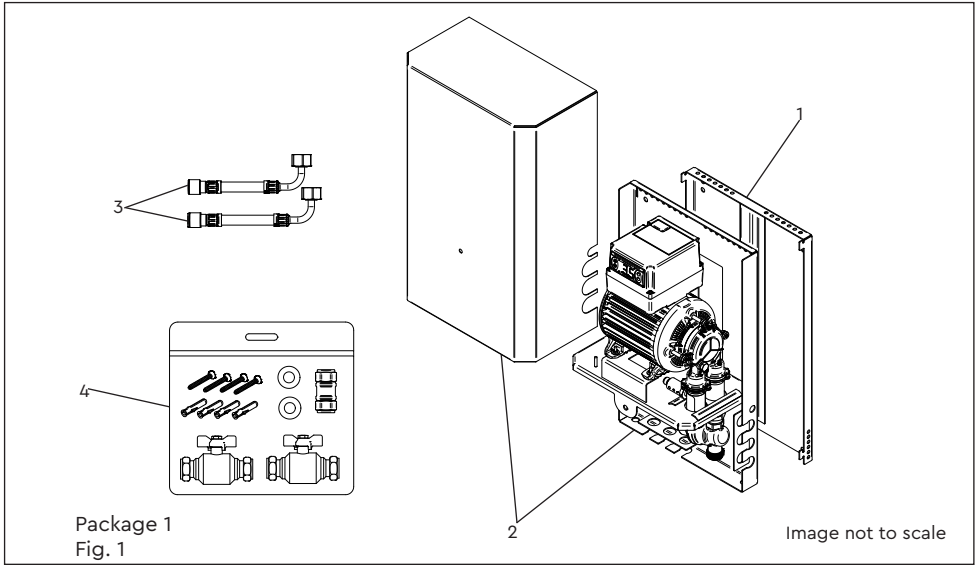

| Item      |   | Description        | Qty | Item             |   | Description        | Qty |
|-----------|---|--------------------|-----|------------------|---|--------------------|-----|
| Package 1 | 1 | Mounting tray      | 1   | Package 1 cont.. | 4 | Hose washers       | 2   |
|           | 2 | Pump assembly      | 1   |                  | 4 | Fixing screws      | 4   |
|           | 3 | Hoses              | 2   |                  | 4 | Wall plugs         | 4   |
|           | 4 | Ball valve         | 2   | Package 2        | 1 | Ball valve         | 1   |
|           | 4 | Single check valve | 1   |                  | 2 | Single check valve | 1   |

Your product may vary slightly from the picture above.

Cont ...

## 1 INTRODUCTION

1.1 Congratulations on buying a Mainsboost Charger MBC 12 system, designed to offer consistent and reliable water services throughout the property and the only system available that is patent protected No. GB2349908.

1.2 **Patents, Trademarks & Trade Names:**  
**'Mainsboost' 'Mainsboost Plus™' and 'Mainsboost Charger' are registered Trademarks of Stuart Turner Ltd.**

Stuart Turner Ltd will treat any infringement of the patent very seriously and therefore recommend that any questions regarding application be brought to the company for consideration.

1.3 **How the Mainsboost Charger MBC 12 System works:**

The Mainsboost pressure vessel stores water from the rising main in a sealed water chamber, separated from the air space by a rubber diaphragm and pressurised to an optimum setting. When water is drawn off by downstream services, the water from the mains is supplemented by the water from the Mainsboost unit to provide a balanced supply at consistent pressure to downstream services.

On occasions where the static pressure is less than 2 bar, a charger pump unit can be used to ensure sufficient pressure is available for the Mainsboost system to continue to function correctly.

The Mainsboost Charger MBC 12 pipework manifold incorporates a unique 'green energy' bypass. If the incoming mains water supply delivers more than 12 l/min this bypass should be left open to allow any additional flow rate to pass directly into the Mainsboost pressure vessel via the integral non-return valve. If the incoming flow rate is less than 12 l/min the bypass valve should be left closed in order to ensure optimum efficiency of the Charger pump.

## 2 IMPORTANT FACTS READ BEFORE COMMENCING INSTALLATION

### A Commissioning

2.11 Ensure the pump is primed as described in the priming section before starting, damage to the shaft seal will result otherwise. See Section 8.16 – Commissioning.

### B Water temperature

This unit is designed for cold water applications only which should not exceed the following values:

2.12 The maximum allowable water temperature is 35 °C.

2.13 The minimum allowable water temperature is 4 °C.

### C Pipework – General

2.14 **Secure pipework:** Ensure pipework to and from the Mainsboost Charger MBC 12 is independently supported & clipped to prevent forces being transferred to inlet and outlet branches of pump. Flexible hoses supplied must be used.

2.15 **Flux:** Solder joints must be completed and flux residues removed prior to pump installation (**flux damage will void any warranty**).

2.16 **Pipework design:** Care should be taken in the design of pipework runs to minimize the risk of air locks e.g. use drawn bends rather than 90° bends.

### D Plumbing Installation Regulations

2.17 The plumbing installation must comply with the current water and building regulations.

2.18 The plumbing installation must be installed by a qualified person.

### 3 LOCATION – GENERAL



- 3.11 **Access:** For emergencies and maintenance the Mainsboost Charger MBC 12 must be easily accessible.
- 3.12 **Protection:** The system must be located in a dry position, and protected from freezing. Avoid environments which have a high ambient temperature, high humidity or excessive condensation and salt damage, etc.
- 3.13 **Ventilation:** Ensure an adequate air flow to cool the pump. Separate the pump from other appliances that generate heat.
- 3.14 **Safety:** The motor casing can become very hot under normal operating conditions. Care must be taken to ensure it cannot be touched during operation.
- 3.15 **Water retention:** Site the pump in a location where in the unlikely event of a water leak, any spillage is contained or routed to avoid electrics or areas sensitive to water damage.
- 3.16 **Static inlet pressure:** Ensure the static inlet head at the pump does not exceed the values shown in the table under point 7.13.
- 3.17 **Incoming mains water pressure:** The incoming water pressure of at least 0.1 bar is required.
- 3.18 Ensure that location of the unit allows adequate space to give reasonable access to all parts to accommodate service/commissioning.
- 3.19 **Ambient temperature:** The pump must be sited in a location where the maximum ambient temperature does not exceed 40 °C.
- 3.20 **Pipework:** Pipework should be sized to ensure optimum performance of the system.
- 3.21 **Direction of flow:** See Fig. 2 to identify the suction and discharge connections.

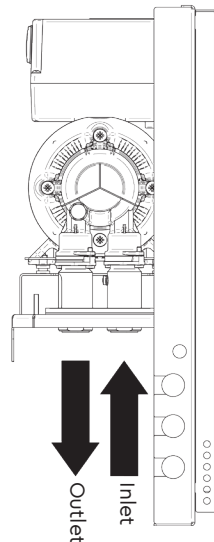

Fig. 2

## 4 TERMINOLOGY

### 4.11 System Designation:

It is important to understand what upstream and downstream refers to before starting the installation.

### 4.12 Upstream

The term 'Upstream' refers to the system configuration from the consumer's stopcock to the point where the supply reaches the inlet port of the Mainsboost Charger MBC 12 Pump.

### 4.13 Downstream

The term 'Downstream' refers to the system configuration from the outlet tapping on the Mainsboost Charger MBC 12 Pump, along the distribution header (if configured in this way) and into the distribution pipework and outlets. This includes hot and cold services where both are present (see Fig. 3).

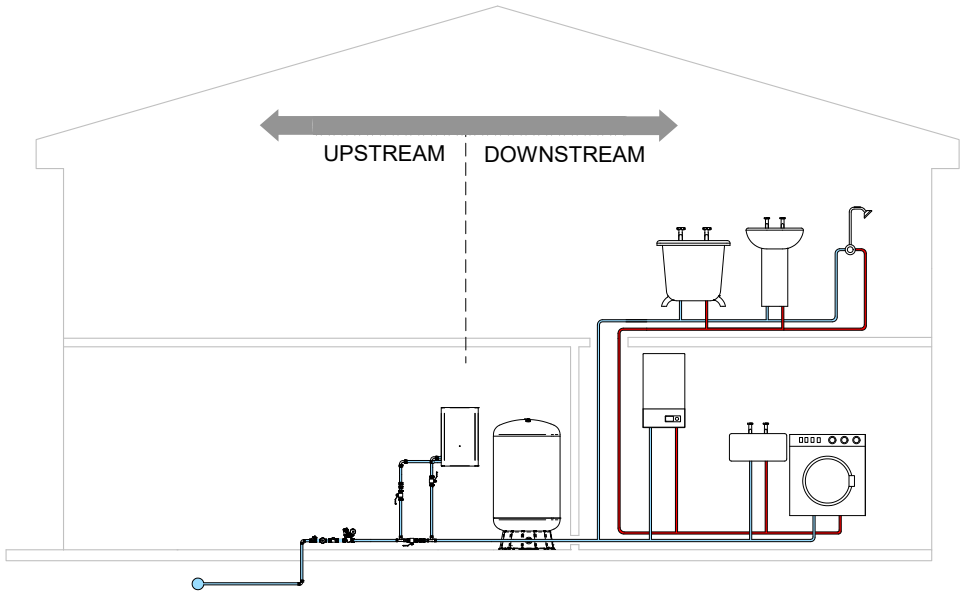
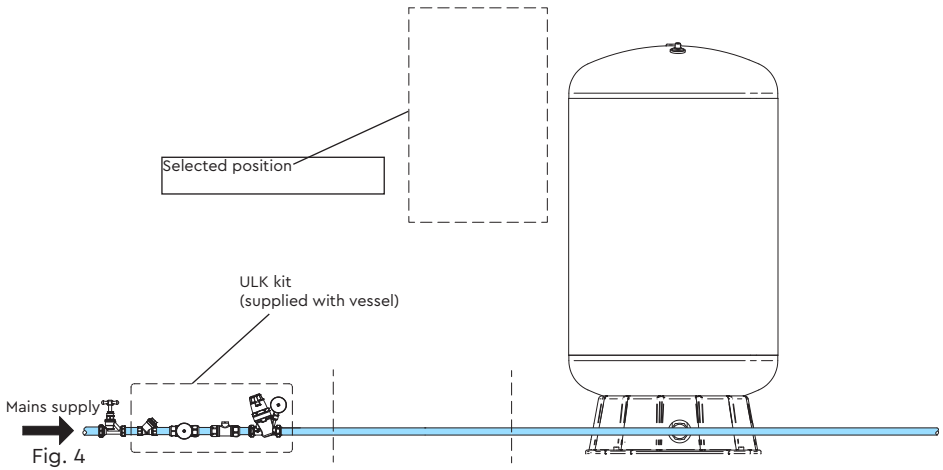

Fig. 3 System designation

## 5 INSTALLATION

Select best position to mount Charger pump unit (Fig. 4).



- 1) Fit mounting plate onto wall ensuring level (Fig. 5).
- 2) Hook pump assembly onto mounting plate and secure in place using M6 set screw (Fig. 5).

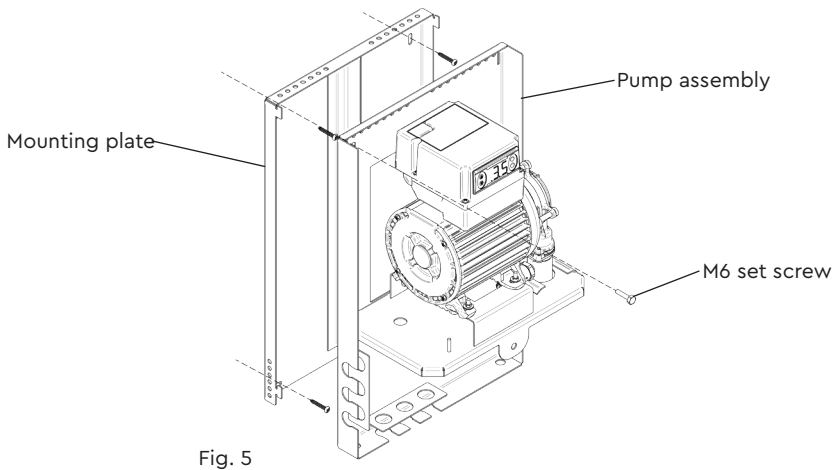

Cont ...

- 3) Your charger will have been supplied with either a green energy lever valve and check valve to suit the main water supply size of (22, 28 or 35 mm). Having ensured the stopcock is turned off and (if installing on an existing Mainsboost system) drained it, remove a section of pipe to allow fitting of 2 tee pieces (not supplied), the lever valve and check valve (Fig. 6).
- 4) The Charger unit has been designed to allow pipework connections to be made in the most convenient way, select the best route.
- 5) Ensure the PRV is securely fitted and connect the flexible hoses provided, routing them to the desired case exit points (Fig. 6).
- 6) Care should be taken not to kink the hoses or bend them through an angle greater than 30 degrees.
- 7) Route 15 mm feed and return from the tees inserted in the main, passing through the isolating valves supplied and the check valve (fitted in the feed line only) (Fig. 6).
- 8) Ensure grommets are fitted correctly in all case apertures to ensure the pipework **does not** vibrate against the case (Fig. 6).

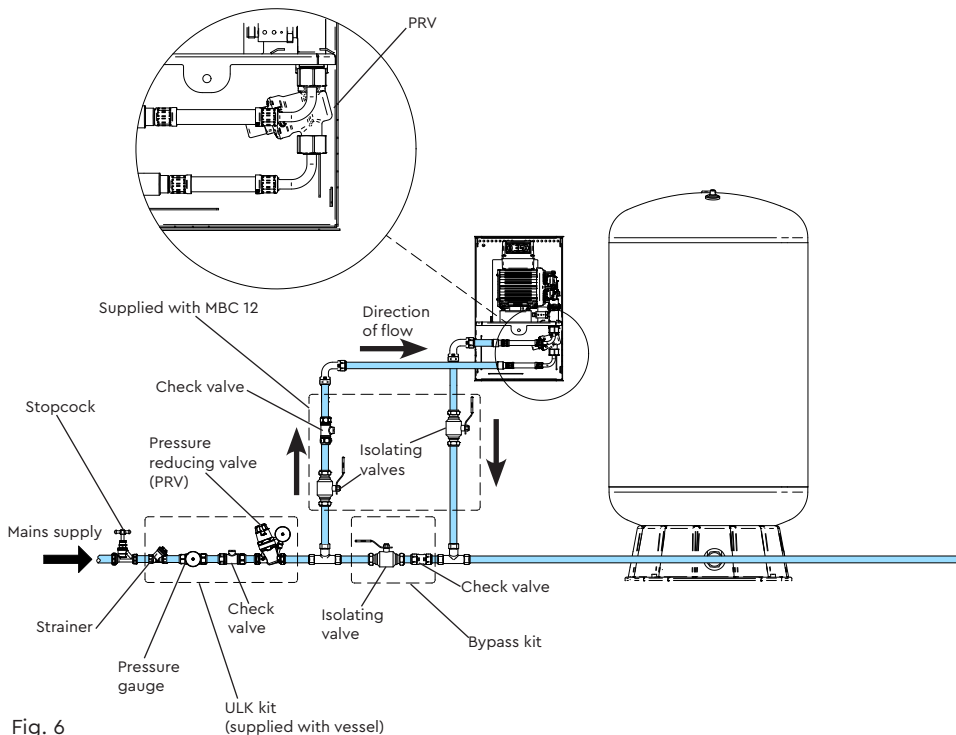

Fig. 6

## 6 ELECTRICAL



- 6.11 **Regulations:** The electrical installation must be carried out in accordance with the current local regulations by a qualified person.
- 6.12 **Safety:** In the interests of electrical safety a 30 mA residual current device (**R.C.D. not supplied**) should be installed in the supply circuit. This may be part of a consumer unit or a separate unit.
- 6.13 Before starting work on the electrical supply ensure power supply is isolated.
- 6.14 **DO NOT** allow the supply cord to contact hot surfaces, including the motor shell, pump body or pipework. The cord should be safely routed and secured by cable clips.
- 6.15 **Earthing:** This appliance must be earthed via the supply cord, which must be correctly connected to the earth point located in the terminal box.
- 6.16 **Connections:** The pump must be permanently connected to the fixed wiring of the mains supply using the factory fitted supply cord, via a dedicated double pole switched fused spur off the ring main.
- 6.17 **Wiring of connection unit:**



**WARNING: This appliance must be earthed.**

The wires in the mains lead (supply cord) are coloured in accordance with the following code:

Green and Yellow: Earth

Blue: Neutral

Brown: Live

As the colours of the wires in the mains lead of this appliance may not correspond with the coloured markings identifying the terminals in your connection unit proceed as follows:

- The wire which is coloured green and yellow must be connected to the terminal in the connection unit which is marked with the letter E or by the earth symbol:  or coloured green or green and yellow.
- The wire which is coloured blue must be connected to the terminal which is marked with the letter N or coloured black.
- The wire which is coloured brown must be connected to the terminal which is marked with the letter L or coloured red.

## 6.18 Wiring diagram:

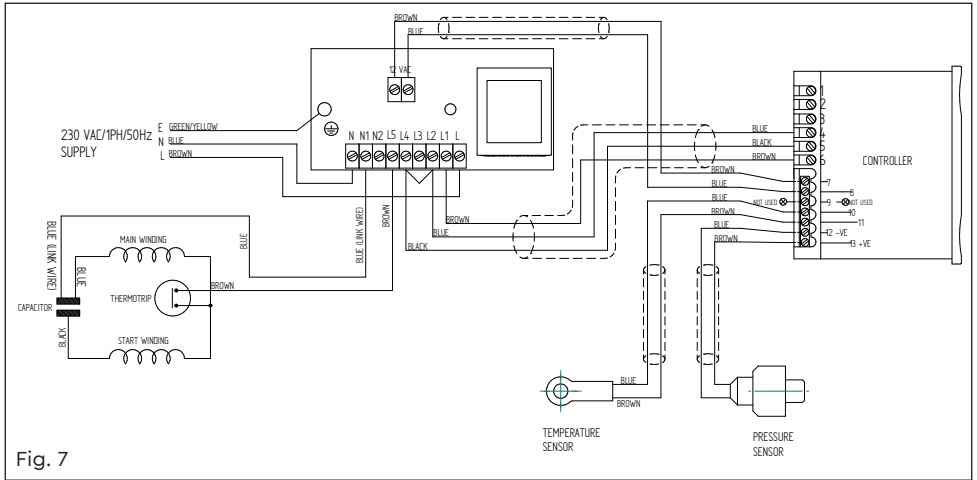

Fig. 7

6.19 **Fuse:** All models should be protected by a 3 Amp fuse.

6.20 **Supply cord replacement:**



**The internal wiring within the terminal box is routed and secured to ensure compliance with the electrical standard EN 60335-1. It is essential that prior to any disturbance of this internal wiring, all cable routing and securing details are carefully noted to ensure re-assembly to the same factory pattern is always maintained.**

6.21 If the supply cord is to be changed or damaged, it must be replaced by a special cord available from Stuart Turner or one of its approved repairers.

## 7 COMMISSIONING

7.11 **System check:** Ensure that the electrical supply to the pump is switched off before opening the mains water supply stopcock and checking for leaks.

7.12 **Check mains static pressure:**

- Now close outlets and check pressure gauge after 'Y' strainer – for static mains pressure and note it.
- Turn stopcock off and leave outlet taps open.

7.13 Check the chart below for the correct pump pressure setting against the static mains pressure recorded.

| MBC 12 pump max. set pressure | Static mains pressure | Set vessel pre-charge pressure to | Differential | Set PRV maximum setting to |
|-------------------------------|-----------------------|-----------------------------------|--------------|----------------------------|
|                               | bar                   | bar                               | bar          | bar                        |
| 3 bar                         | 1.5                   | 1.0                               | 2.0          | 2.0                        |
| 3 bar                         | 2.0                   | 1.0                               | 2.0          | 2.0                        |
| 3.5 bar                       | 2.5                   | 1.5                               | 2.0          | 2.5                        |
| 3.5 bar                       | 3.0                   | 1.5                               | 2.0          | 2.5                        |

**Warning: Note PRV setting must not exceed 5.0 bar.**

Refer to the Mainsboost instruction manual for the correct commissioning of the vessels.

### 7.14 Control module:

The control module (Fig. 8) has been factory pre-set to the following conditions.

| Settings as per factory preset: |                        |
|---------------------------------|------------------------|
| Set point                       | SP: 3 bar              |
| Diff pressure                   | DIFF: 0.5 bar          |
| Low pressure                    | LPR: 0.2 bar           |
| High pressure                   | HPR: 4.5 bar           |
| Pump run timer                  | PRT: 180               |
| Pump number                     | NPM: 2 (do not tamper) |
| CRE setting                     | 0                      |

Should the parameter need changing follow these steps.

- The pump parameters are displayed in the following sequence:  
Set point (SP),  
Differential (DIFF),  
Low pressure trip (LPR),  
High pressure trip (HPR),  
Pump run timer (PRT),  
Pump Number (NPM),  
Relay setting (CRE),  
Number of alarms (NAL1/NAL2),  
Hours run (HR1/HE2).
- Press and hold the set button for 5-7 seconds. (This gains access to the pump parameters).
- Press the up/down arrows to change the selected parameter(s) to the desired value.
- After changing the required parameter(s) press the set button twice in quick succession to lock the new value into the controller memory.
- It is possible to scroll through all the pump parameter values by simply pressing the set button once after each parameter value has been displayed.

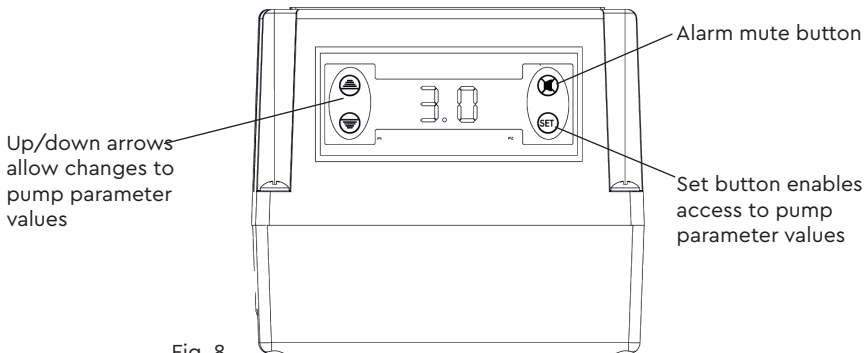

Fig. 8

- 7.15 On completion of the installation, follow the commissioning process below.
- **Leave** pump power switched off.
  - **Leave** all outlet valves closed.
  - Turn on stopcock and open inlet ballvalve, both pressure gauges on inlet and PRV will start to show movement as the mains pressure fills the system.
  - Check for leaks on all joints made.
  - Dependant on the incoming mains pressure the vessel will start to fill with water.
  - Switch on the power to the pump, it will sense the pressure in the system and if less than 3 bar will start to assist filling of the system.
  - Close Mainsboost vessel isolation valve
  - Allow the pump to continue running until air has been completely purged from the system, all outlets will have to be opened and closed.
  - All outlets have been closed, open the Mainsboost vessel isolation valve.
  - The pump will continue to run to charge the system, this may take some time dependant on size and number of Mainsboost vessels fitted.

Once the system is completely full the pump will stop and only start again if the Mainsboost vessel pressure drops below set point minus the differential of the pump control.

#### Green Energy

– Bypass

If the flowrate is greater than 12 l/min leave the isolation valve open.

If the flowrate is less than 12 l/min close the isolation valve.

## 8 TECHNICAL SPECIFICATION

| Pump           |                                 | Mainsboost Charger<br>MBC 12-22<br>44725   | Mainsboost Charger<br>MBC 12-28<br>44726 |
|----------------|---------------------------------|--|--|
| General        | Guarantee                       | 5 years  |  |
|                | WRAS approval                   | 1501305  |  |
|                | Approvals                       | WRAS, CE   |  |
|                | System patent no.               | 2349908  |  |
|                | Typical noise                   | 60 dB(A)   |  |
| Features       | Pump type                       | Peripheral   |  |
|                | Bypass kit                      | 22 mm  | 28 mm                                    |
|                | Mounting                        | Wall   |  |
|                | Flexible hoses                  | 2  |  |
|                | Dry run protection              | ✓  | ✓  |
| Materials      | Pump body                       | Brass  |  |
|                | Impeller                        | Brass  |  |
|                | Mechanical seal                 | EPDM / PTFE / Al. Oxide  |  |
| Performance    | Maximum head – closed valve     | 4.3 bar (43 metres)  |  |
|                | Maximum working pressure*       | 600 kPa (6 bar)  |  |
|                | Maximum ambient air temperature | 40 °C  |  |
|                | Min / Max water temperature     | Min 4 °C / Max 35 °C   |  |
| Connections    | Pump connections                | G ¾ male   |  |
| Flexible hoses | Connections                     | 15 mm push-in x G ¾ female x 235 mm long<br>15 mm push-in x G ¾ female x 200 mm long |  |
| Motor          | Type                            | Induction (thermal trip/auto reset)  |  |
|                | Duty rating                     | Continuous (S1)  |  |
| Electrical     | Power supply (Vac/Ph/Hz)        | 230 V a.c. / 1 / 50 Hz   |  |
|                | Power consumption – P1          | 398 Watts  |  |
|                | Current – full load             | 1.8 Amps   |  |
|                | Fuse rating                     | 3 Amps   |  |
|                | Power cable length              | 1.5 metres (pre-wired)   |  |
| Physical       | Enclosure protection            | IPX4   |  |
|                | Width                           | 290 mm   |  |
|                | Depth                           | 180 mm   |  |
|                | Height – excluding hoses        | 465 mm   |  |
|                | Weight – including fittings     | 15.3 Kg  |  |

Stuart Turner reserve the right to amend the specification in line with its policy of continuous development of its products.

\*Note: The maximum pressure that can be applied to the pump under any installation conditions.

8.11 **Noise:** The equivalent continuous A-weighted sound pressure level at a distance of 1 metre from the pump does not exceed 70 dB(A).

Cont ...

## 9 TROUBLE SHOOTING GUIDE

### 9.11 Alarm

The Charger™ controller has an internal alarm buzzer.

When the alarm is triggered the buzzer will sound and a related failure message will appear on the display.

The alarm will sound when the following conditions occur:- when alarm sounds investigate and rectify cause.

Then press alarm mute button,  alarm will stop.

#### Remote alarm option

A remote alarm option is available, the Charger™ unit would need to be ordered in advance pre-wired for this option. Please consult Stuart Turner. Attempting to change the Charger™ MBC 12 wiring will invalidate the guarantee.

### 9.12 Alarm fault codes

|   | Displayed message                  | Fault description   | Action   |
|---|------------------------------------|---|--|
| A | <b>Hnt</b><br>high temp cut out    | Pump head overheating – head temperature has exceeded the set Hnt value | Allow pump to cool. Ensure the pump inlet check valve and by pass are clear of debris.   |
| B | <b>Hpr</b><br>Hi pressure cut out  | The current pressure rises above the Hpr value                          | Investigate the cause, then turn power off and on to reset or allow self reset.          |
| C | <b>Lpr</b><br>Low pressure cut out | The current pressure falls below the set Lpr value                      | Investigate the cause, then turn power off and on to reset or allow self reset.          |
| D | <b>Prt</b><br>pump run time        | The pump has run longer than the set Prt value                          | Investigate cause, then turn power off and on. Contact Stuart Turner if problem persists |
| E | <b>PF1</b>                         | Pump failure  | Contact Stuart Turner.   |

All alarms automatically reset except Prt, pf1.

## 10 YOUR GUARANTEE

Congratulations on purchasing a Stuart Turner Mainsboost Charger MBC 12 Pump.

We are confident this product will give you many years of trouble free service as all our products are manufactured to the very highest standard.

The Mainsboost Charger MBC 12 pump is covered by the **five year** guarantee.

Within the guarantee period we will repair, free of charge, any defects in the Mainsboost Charger MBC 12 resulting from faults in material or workmanship, repairing or exchanging the part affected or whole unit as we may reasonably decide.

Not covered by this guarantee: Damage arising from incorrect installation, improper use, unauthorised repair, normal wear and tear and defects which have a negligible effect on the value or operation of the unit.

Reasonable evidence must be supplied that the product has been purchased within the guarantee term prior to the date of claim (such as proof of purchase or the product serial number).

This guarantee is in addition to your statutory rights as a consumer. If you are in any doubt as to these rights, please contact your local Trading Standards Department.

In the event of a claim please telephone '**TechAssist**' customer support.

**+44 (0) 800 31 969 80**

You should obtain appropriate insurance cover for any loss or damage which is not covered by Stuart Turner Ltd in this provision.

Please record here for your records.

| TYPE NO. | SERIAL NO. | DATE PURCHASED |
|----------|------------|----------------|
|          |            |                |



**DECLARATION OF CONFORMITY**

**Machinery Directive – 2006/42/EC**

BS EN 12100, BS EN 809

**Low Voltage Directive – 2014/35/EU**

BS EN 60335-1, BS EN 60335-2-41

**EMC Directive – 2014/30/EU**

BS EN 55014-1, BS EN 55014-2, BS EN 61000-3-2, BS EN 61000-3-3,  
BS EN 61000-4-2, BS EN 61000-4-3, BS EN 61000-4-4, BS EN 61000-4-5, BS EN 61000-4-6,  
BS EN 61000-4-11

**EMF Directive – 1999/519/EC**

BS EN 62233

**RoHs Directive – 2011/65/EU**

**WEEE Directive – 2012/19/EU**

IT IS HEREBY CERTIFIED THAT THE STUART ELECTRIC MOTOR DRIVEN PUMP AS SERIAL NUMBER BELOW, COMPLIES WITH THE ESSENTIAL REQUIREMENTS OF THE ABOVE E.E.C. DIRECTIVES.



RESPONSIBLE PERSON  
AND MANUFACTURER

STUART TURNER LIMITED  
HENLEY-ON-THAMES, OXFORDSHIRE  
RG9 2AD ENGLAND.

Signed .....  ..... Engineering Manager

Stuart Turner are an approved company to BS EN ISO 9001:2015



Stuart Turner Ltd, Henley-on-Thames, Oxfordshire RG9 2AD ENGLAND

Tel: +44 (0) 1491 572655, Fax: +44 (0) 1491 573704

info@stuart-turner.co.uk www.stuart-turner.co.uk