

WASTEFL0

BC3 – Boiler Condensate Pump Installation, Operation & Maintenance Instructions

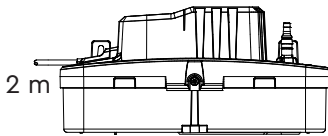

In the box



2 m

X 1

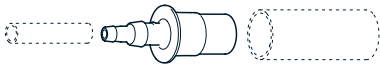

X 1

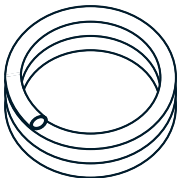

X 1
10 mm I.D. x 6 m

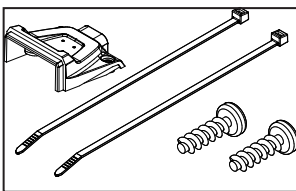

X 1 – Cable clamp
X 2 – Cable ties
X 2 – Cable clamp
screws

Performance

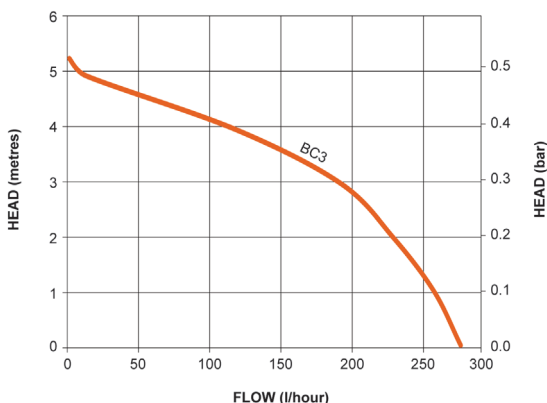

Safety

- If pump fails, the safety float switch will shut off boiler operation.
- Pump suitable for boiler with heat output 200 kW (0.68 m Btu/h) condensate PH value >2.2+.



Do not handle pump in wet conditions or with wet hands

- To reduce the risk of electric shock, ensure electrical supply is permanently wired to earth.
- Disconnect supply before opening.
- This appliance should **ONLY** be fitted and serviced by a competent & qualified installer.
- This appliance must be provided with means for disconnection that is incorporated into the fixed wiring in accordance with the relevant local wiring regulations.
- This appliance is not intended for use by persons (including children) with reduced physical, sensory or mental capabilities, or lack of experience and knowledge, unless they have been given supervision or instruction concerning use of the appliance by a person responsible for their safety.
- **This appliance must be earthed.**

Specification

- Inlet up to 27 mm
- Tank capacity: 2 litre
- High level safety cut-out
- Outlet size: 6 or 10 mm
- Maximum water temperature: 60 °C

Installation

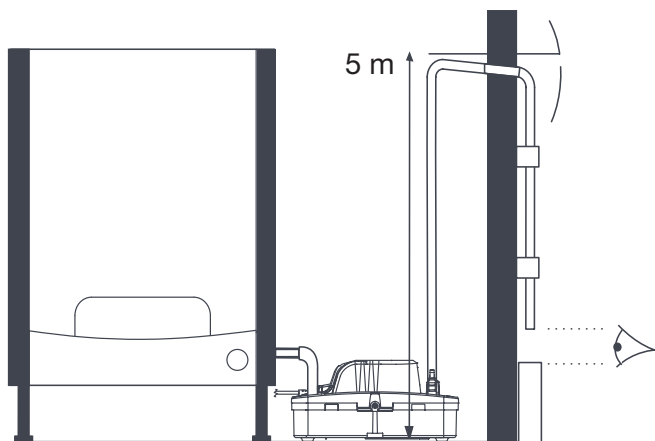

Position the pump alongside the boiler so that the water flows into the top inlet hole.

Connect the supplied 6 m length of 10 mm I.D. tubing to the pump outlet using cable ties supplied.

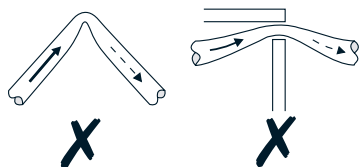
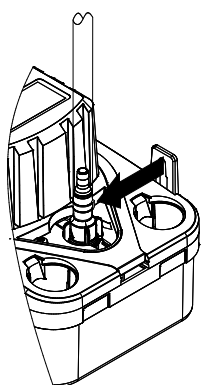

Ensure that there are no kinks or trapped parts.

- If it is not possible to create a downward slope, you must create an inverted U directly above the pump at the highest point.
- Where the tubing from the pump is connected directly to the soil stack or waste pipe, there must always be either a waste trap after the tubing connection or a 75 mm U trap formed within the tubing.
- Where the outlet from the pump is connected to an external soil and vent stack extra care is necessary to ensure that the condensate pipe could not be blocked through the condensate freezing.
- This pump is designed to sit level on its base or be fitted level to a vertical surface. Mounting brackets are factory fitted to the unit.

Power Supply

- 230 V AC 50 Hz 0.8 A
- Class I appliance
- 3.0 A safety switch, normally closed

Electrical connections

- **Live:** Brown
- **Neutral:** Blue
- **Safety switch:** 2 x Black Earth – Yellow/Green

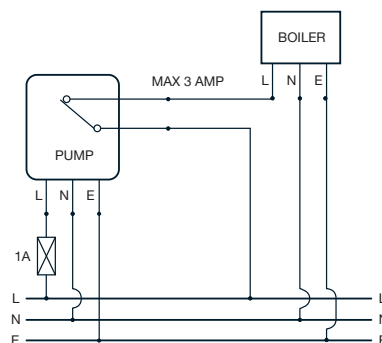

The pre-wired switch must always be utilised.

- If a fused plug is used, a 3 amp fuse is recommended.

Commissioning & Maintenance

- Before servicing the pump, make sure the electrical power is disconnected at the fuse box for both the pump and boiler.
- When commissioning the pump please check for debris in the pump tank. Remove any material that might block the drain line or drain into the Boiler Condensate Pump.
- The pump reservoir can be removed with ease for cleaning purposes by undoing the screw located at the front of the pump, depressing the front and allowing the reservoir to be moved downwards (care should be taken as there may be water in the reservoir). Note: The pump does not need to be removed from its fixings to clean the reservoir. The quick release outlet barb can be removed very easily by twisting and pulling out.
- The pump should be flushed through with anti-bacterial wash every 6 months to avoid sludge build up in the pump reservoir. Note: Contractors should satisfy themselves that any chemicals used are suitable and will not damage the pump.
- If the supply cord is damaged the pump must be switched off until the supply cord is replaced by a suitably qualified person to avoid a hazard.
- **IMPORTANT:** The pre-wired switch must always be utilised, this will stop the boiler system in the event of pump failure.
- Pump should be filled with water until motor runs, check for leaks and proper discharge of water.

Contact TechAssist for further help.

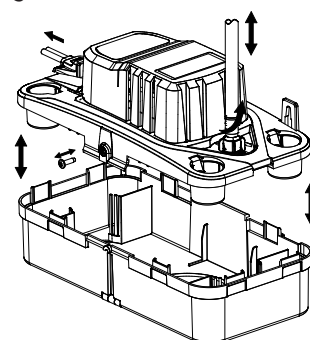

Stuart Turner Ltd, Henley-on-Thames, Oxfordshire RG9 2AD ENGLAND
 Tel: +44 (0) 1491 572655, Fax: +44 (0) 1491 573704
 info@stuart-turner.co.uk www.stuart-turner.co.uk