



The VIP 6000 offers exceptionally diverse opportunities.

Each of the three frames conveys its own design line with special functions. Each enclosure is manufactured to order and covers every conceivable requirement.

### Protective rights for frames:

German patent no. 195 25 876  
 German patent no. P 41 09 695  
 European patent no. 0 505 681 with validity for DE, FR, GB, IT  
 European patent no. 0 839 299 with validity for FR, GB, IT  
 Jap. patent no. 3199745  
 Jap. patent no. 3221506  
 South Korean patent no. 97-70 77 12

US patent no. 5,921,050  
 German registered design no. M 94 02 325  
 IR reg. design no. DM/053 168 with validity for BE, CH, FR, IT, NL  
 Austral. reg. des. no. 125352  
 Japan. reg. design no. 983 783  
 Austrian registered design no. 17467

Swedish registered design no. 58 996  
 UK reg. des. no. 2047055  
 US design patent no. des. 375,726  
 Brazilian design pattern no. DI 5500 709-0

**Approvals,**  
 see page 37.

### Three customised design lines



**Wide frame**  
 A frame and handle in one; the ideal choice where enclosures with fins all round are used for better heat dissipation.



**Narrow frame**  
 An eye-catching design with its stylish lines, particularly for small enclosures.



**Combined frame**  
 The soft-coated frame at the sides is particularly sympathetic to the touch. This is also suitable for use with enclosures with fins at the sides.

### Enclosure/rear panels

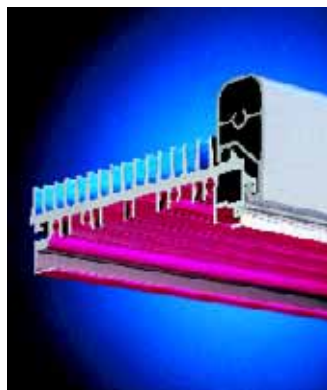

There is a choice of five installation depths (155, 185, 295, 328 and 438 mm). Either screw-fastened or hinged, depending on requirements.

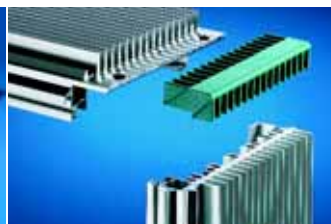

Because it is equipped with cooling fins, the VIP 6000 solution often eliminates the need for active cooling components.



Screw-fastened or vertically/horizontally hinged – choose the rear panel to suit your servicing requirements.

### Attachment/trim

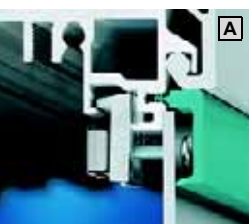

Each attachment point all round is achieved with sliding retaining claws.



The screw heads disappear stylishly beneath the cover trim (A). Front panels with threaded bolts may also be combined with the end trim (B) or spacer trim (C).



Panels with screw clamp (D) are mounted with the end trim.



# Rittal Command Panel VIP 6000

## Configuration examples

1.4

Rittal Command Panel VIP 6000

### Nothing's impossible . . .

A kaleidoscope of incredible solution diversity. Configure your perfect enclosure.

Allow yourself to be inspired by these examples: e. g. by the front divisions, the handle arrangements, the enclosure depths, and much more besides.



### . . . with wide frame.

A small selection from the wide range of opportunities available. For enclosures with cooling fins, the wide frame is important.

#### Example A

- Operating housing, 155 mm deep
- Support for keyboards with cable entry grommet
- Frame connector, adjustable
- Vertical handle set
- With vertical and horizontal cross member
- Support arm connection at the bottom

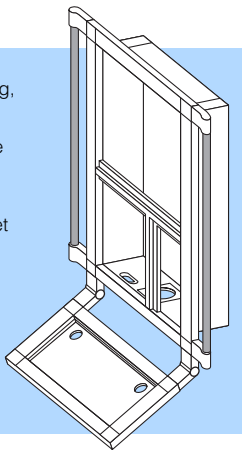

#### Example B

- Operating housing, 155 mm deep
- Side keyboard housing, 44 mm deep
- Frame connector, rigid
- Vertical handle set with clipboard
- With horizontal cross member and vertical sealing bar
- Support arm connection at the bottom

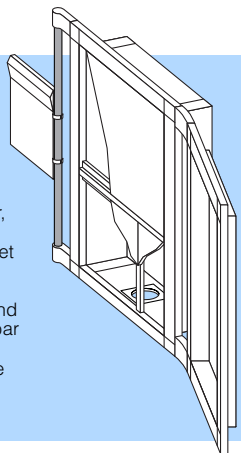

#### Example C

- Operating housing, 155 mm deep
- Keyboard housing at top, 44 mm deep, with frame connector, adjustable
- Keyboard housing at bottom, 44 mm deep, with frame connector, rigid
- Cable tube, flexible
- Vertical handle sets
- Support arm connection at the bottom

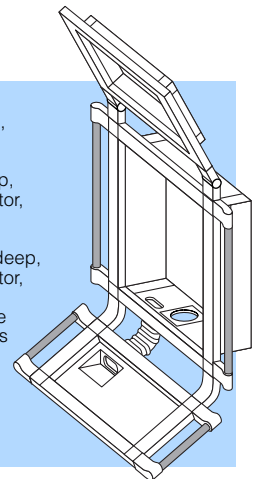

#### Example D

- Operating housing, 155 mm deep, with vertical handle set
- Keyboard housing with handle set horizontal and vertical
- Cable tube, flexible
- Support arm connection at the bottom

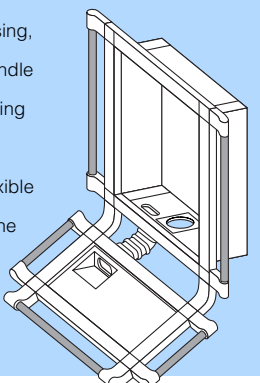

#### Example E

- Operating housing, 155 mm deep
- Keyboard housing, 105 mm deep
- Frame connector and cable tube, rigid
- Support arm connection at the bottom

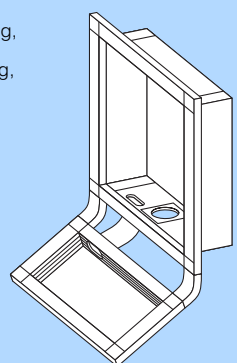

#### Example F

- Operating housing, 438 mm deep, e. g. for colour screen
- With handle set vertical
- With horizontal sealing bar
- Support arm connection, top

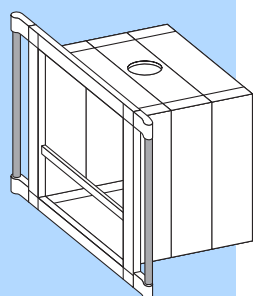

### ... with narrow frame.

Stylish lines for small enclosures and those without fins.

#### Example G

- Operating housing, 155 mm deep
- With U handle, vertical
- Enclosure connector, adjustable, on the left-hand side for vertically hinged wall mounting

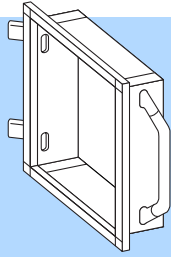

#### Example H

- Operating housing, 155 mm deep
- Keyboard housing, 105 mm deep
- Enclosure duct connector
- Support arm connection at the bottom

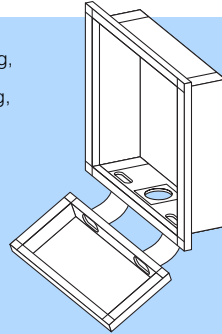

#### Example I

- Operating housing, 155 mm deep
- Keyboard housing, 44 mm deep
- Hinged frame connector
- U handles, vertical
- Cable tube, flexible
- Support arm connection, top

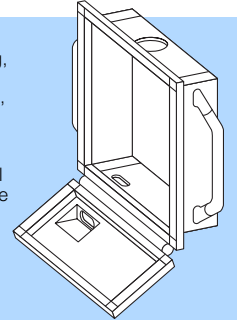

#### Example J

- Operating housing, 155 mm deep
- Keyboard housing, 44 mm deep
- With enclosure bar connector
- With corner handles
- Cable tube, flexible
- Support arm connection at the bottom

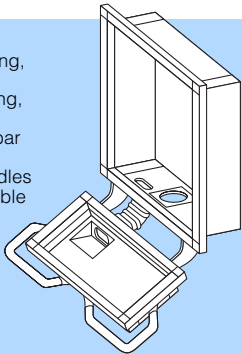

#### Example K

- Operating housing, 155 mm deep
- Keyboard housing, 44 mm deep
- Enclosure bar connector
- Support arm connection at the bottom

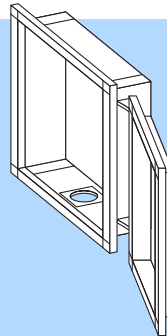

#### Example L

- Operating housing, 185 mm deep, hinged
- Keyboard housing, 44 mm deep
- Enclosure bar connector
- Cable tube, flexible
- Support arm connection, top

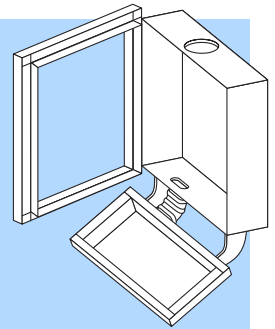

### ... with combined frame.

The soft-coated frame at the sides is particularly sympathetic to the touch.

#### Example M

- Operating housing, 155 mm deep
- Keyboard housing, 44 mm deep
- Enclosure bar connector
- Cable tube, flexible
- Support arm connection, top

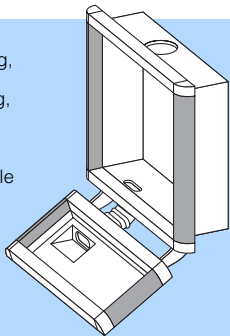

#### Example N

- Operating and keyboard housing in various widths
- Keyboard housing, 105 mm deep, with cross member
- Enclosure duct connector
- U handle, horizontal
- Support arm connection, top

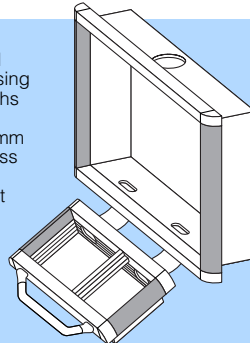

#### Example O

- Operating housing, 155 mm deep
- Keyboard housing, top, with hinged frame connector
- Keyboard housing, bottom, with enclosure bar connector
- Cable tube, flexible
- Support arm connection, top

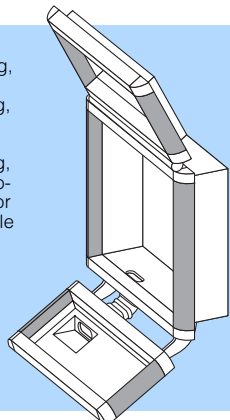

#### Example P

- Operating housing, 155 mm deep
- Corner handles
- Support arm connection, top

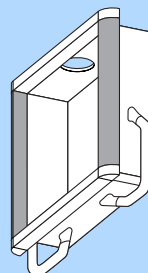

# Command Panel VIP 6000

## Selection: Operating housing/keyboard housing

We need the following information in order to deal with your enquiry/order:

- Model No. front frame: CP 6392.X09
- The dimensions and number of panels/front panels to be installed in the operating/keyboard housing
- Design code number for the operating/keyboard housing

**Protection category:**  
IP 65 (if the opening in the enclosure is covered or sealed in accordance with the protection category).

Order form, available on the Internet.

### 1. Front frame

Select the frame to match your requirements. It is automatically used for a keyboard housing as well.

Model No. CP  
Command Panel

6 3 9 2 . 0 9

Model No. CP  
Keyboard housing

6 3 5 1 . 0 9



.009



**Wide frame**  
Extruded aluminium section

Die-cast zinc corner pieces  
Colour: RAL 7035<sup>1)</sup>  
Finely-textured

0



.109



**Combined frame**  
Extruded aluminium section

Soft-coated frame similar to RAL 7024 (sides), vertical  
Die-cast zinc corner pieces

**Note:**  
For visual reasons, only enclosures without fins or with fins at the sides should be mounted here.

1

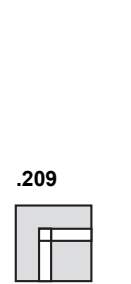

.209



**Narrow frame**  
Extruded aluminium section

Die-cast zinc corner pieces  
**Note:**  
For visual reasons, only enclosures without fins should be mounted here.

2

<sup>1)</sup> Other RAL colours available on request.

## 2. Panel dimensions

### 2.1 For operating housings CP 6392.X09 and

### 2.2 For keyboard housings CP 6351.X09

On the order form, please state the width (B) x height (H) x depth (T) of the control components and the manufacturer/model, with due regard for the installation criteria (see below).

### Checking the installation criteria

Subject to compliance with criteria 1 – 4, front panels/panels may be mounted directly with the appropriate mounting kits, see page 1121.

Otherwise, an adaptor panel is needed – see 3.2, design code number 6, page 218.

The dimensions of the operating panel and keyboard housing are derived from the dimensions of your panel and the number of cross members.

**1** 7 to 13 mm edge spacing of the mounting holes or bolts.

**2** Front panel projection on sides with mounting holes or bolts at least 17 mm, on sides without attachments at least 6 mm.

**3** Front panel thickness varies according to the type of trim section, see page 219, version 3.4.

**4** Installation depths:  
Command Panels = 155 mm, 185 mm, 295 mm, 328 mm, 438 mm.  
Command Panels with 45 mm deep rear panel<sup>1)</sup> = 200 mm, 230 mm, 340 mm, 373 mm, 483 mm.  
Command Panels with 245 mm deep rear panel<sup>1)</sup> = 400 mm, 430 mm, 540 mm, 573 mm, 683 mm.

**5** For versions with a hinged rear panel, the maximum installation depth is reduced by 27 mm in the vicinity of the lock.

<sup>1)</sup> Other depths available on request.

**Note:**  
Load information for installed equipment, see page 1214.

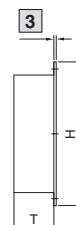
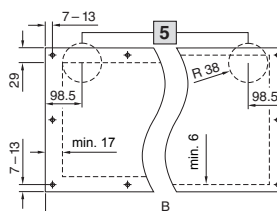
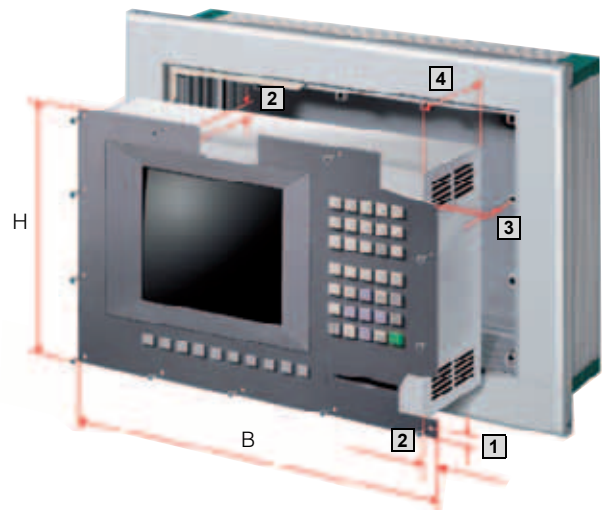

B = Width  
T = Depth

### 3.1 Installation depth

**Material:**

Enclosure: Extruded aluminium section  
 Corner protectors: Plastic, self-extinguishing

**Surface finish:**

Enclosure: Natural-anodised

**Note:**

Support arm connection see 3.6.  
 Drawing view from above.  
 R/h hinge is also possible.

**Detailed drawing,**

see page 1208/1209.



**Installation depth 155 mm**



**Installation depth 185 mm**

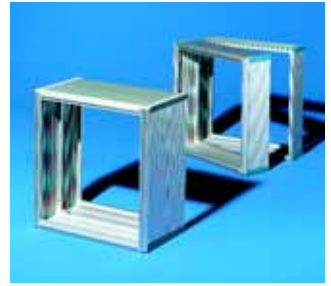

**Installation depth 295 mm**

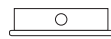

**Screw-fastened**

**3.1**  
**1**

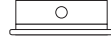

**Screw-fastened**

**3.1**  
**2**

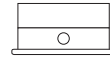

**Screw-fastened**

**3.1**  
**4**

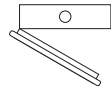

**Hinged<sup>1)</sup>**

**3.1**  
**3**

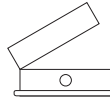

**Hinged<sup>1)</sup>**

**3.1**  
**5**

**Support arm system CP-L**

prepared

**Support arm system CP-XL/CP-Q**

with adaptor CP 6528.5X0



with adaptor CP 6528.5X0



with adaptor CP 6528.5X0

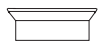

X = 0 (RAL 7030)

X = 1 (RAL 7024)

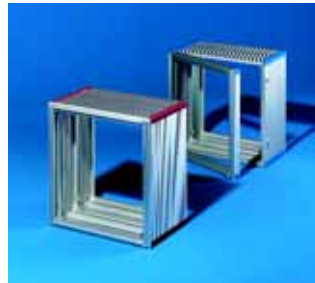

**Installation depth 328 mm**

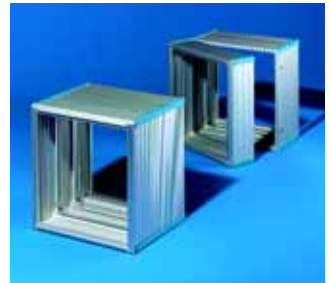

**Installation depth 438 mm**

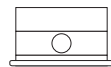

**Screw-fastened**

**3.1**  
**6**

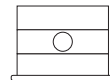

**Screw-fastened**

**3.1**  
**8**

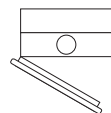

**Hinged<sup>1)</sup>**

**3.1**  
**7**

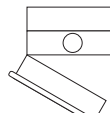

**Hinged<sup>1)</sup>**

**3.1**  
**9**

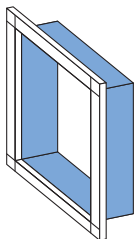

<b>3.1</b>	<b>3.2</b>	<b>3.3</b>	<b>3.4</b>	<b>3.5</b>	<b>3.6</b>	<b>3.7</b>	<b>3.8</b>	<b>3.9</b>
------------	------------	------------	------------	------------	------------	------------	------------	------------

**Support arm system CP-L**

**Support arm system CP-XL/CP-Q**

with adaptor CP 6528.0X0<sup>2)</sup>

prepared

with adaptor CP 6528.0X0<sup>2)</sup>

prepared

<sup>1)</sup> Cam lock with double-bit lock insert may be exchanged for 41 mm lock inserts, type C, see page 956.

<sup>2)</sup> Provided the admissible load capacity of the support arm system is adequate, see page 237.

# Command Panel VIP 6000

## Selection: Operating housings

### 3.2 Front design

#### Cross member

For horizontal and/or vertical division. With channel on both sides for mounting kits, see page 1121.

#### Material:

Extruded aluminium section, RAL 7035



Without cross member

3.2  
0



With one cross member

3.2  
1



With one sealing bar<sup>1)</sup>

3.2  
2

#### Sealing bar

For horizontal and/or vertical division. The "slot-free" division produces a height gain of 28 mm.

#### Material:

Extruded aluminium section 8 x 20 mm, natural-anodised

#### Adaptor plate

#### Material thickness:

3 mm aluminium, natural-anodised.

Please specify the dimensions for the front panel and the desired holes and cut-outs.



With two cross members

3.2  
3



With two sealing bars<sup>1)</sup>

3.2  
4



With one cross member and one sealing bar<sup>1) 2)</sup>

3.2  
5

#### Spacer and built-in trim panel

For additional space for cable entry and for the installation of switches/indicator lights, emergency off/key switches, CD-ROM drives, interfaces etc. With channel on one side for mounting kits, see page 1121.

#### Material:

Extruded aluminium section, natural-anodised.

**Detailed drawing,** see page 1123.



With one adaptor plate (to specifications)

3.2  
6



With spacing and built-in trim panel at the top<sup>3)</sup>

3.2  
7



With spacing and built-in trim panel at the bottom<sup>3)</sup>

3.2  
8

#### ! Also required:

Mounting kit for installing front panels, operating panels and keyboards in operating and keyboard housings, see page 1121.

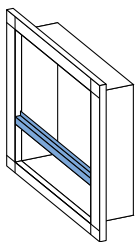

3.1	3.2	3.3	3.4	3.5	3.6	3.7	3.8	3.9
	3.2							

<sup>1)</sup> Not possible with spacer trim (see 3.4).

<sup>2)</sup> Unless otherwise specified: Sealing bar at the top, cross member at the bottom.

<sup>3)</sup> Only for use in conjunction with end trim.

<sup>4)</sup> Screw-fastened from the inside, with cam or l/h hinge on request.



With front panel hinged<sup>4)</sup>

For example, if a disk drive built into the operator panel necessitates free access.

#### Standard design

- Screw-fastened from the outside
- R/h hinge

3.2  
9

### 3.3 Cooling fins

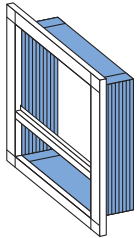

3.1	3.2	3.3	3.4	3.5	3.6	3.7	3.8	3.9
		1						



No fins



3.3  
1

Fins at sides

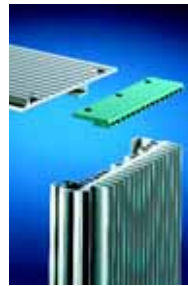

3.3  
2

Fins all round

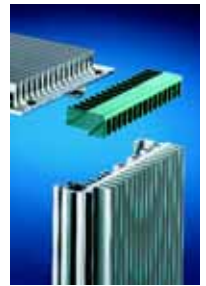

3.3  
3

Fin design is chosen according to the heat loss to be dissipated. Guidelines for dissipatable heat loss, see page 227.

Enclosures in installation depth 185 mm and 328 mm have no fins immediately behind the front frame at a depth of 44 mm. The colour of the corner protectors matches the trim colour selected under 3.5.

### 3.4 Trim types

Detailed drawing, see page 1210.

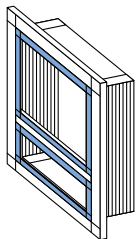

3.1	3.2	3.3	3.4	3.5	3.6	3.7	3.8	3.9
			1					



3.4  
1

**Cover trim**  
To cover the front panel fastening screws. For front panel thickness up to 3.5 mm.



3.4  
2

**End trim**  
Attractively finishes off the space between the front panel and the frame section. For all front panel thicknesses. Only this trim may be selected when installing drawers.



3.4  
3

**Spacer trim**  
For installed equipment flush with the frame section. For front panel thickness approx. 3.5 mm.

### 3.5 Trim colours

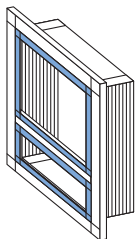

3.1	3.2	3.3	3.4	3.5	3.6	3.7	3.8	3.9
				1				



**Turquoise**  
(similar to RAL 5018)

3.5  
1

**Bright blue**  
(similar to RAL 5005)

3.5  
2

**Bright red**  
(similar to RAL 3001)

3.5  
3

**Pebble grey**  
(similar to RAL 7030)

3.5  
5

**Graphite grey**  
(similar to RAL 7024)

3.5  
6

**Note:**

Enclosure corner protectors are supplied in the chosen colour. Other colours available on request with larger orders.

# Command Panel VIP 6000

## Selection: Operating housings

### 3.6 Support arm/wall and pedestal connection

Users may choose from 4 different support arm systems, see page 237, and a variety of stand systems, see page 286.

**Note:** Support arm connection CP-S for small enclosures with an installation depth of 155 mm is selected by adding an "S" after the design code number.

**Detailed drawing,** see page 1205.

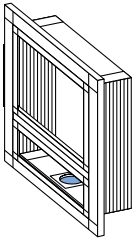

3.1	3.2	3.3	3.3	3.4	3.5	3.6	3.7	3.8	3.9
						3.6			



Without connection **3.6**  
**0**



Connection bottom<sup>1)</sup> **3.6**  
**2**



Connection top<sup>1)</sup> **3.6**  
**1**



Connection top and bottom<sup>1)</sup>, one cover plate included **3.6**  
**3**



Wall connection rigid, see page 1119

<sup>1)</sup> Support arm connection for the narrow variant of connection plate 6528.420, see page 274, housing coupling for desktop mounting 6528.400, see page 273, by additionally specifying the code number: **A**  
for the wide variant of connection plate 6528.430, see page 274, housing coupling for desktop mounting 6528.410, see page 273, by additionally specifying the code number: **B**

### 3.7 Preparations for mounting keyboard housings

**Detailed drawing,** see page 1211.

To fit keyboard housing depth:

Connection of operating housing to keyboard housing: (Selection 4.4, page 225)

Cable tube: (Selection 4.5, page 226)

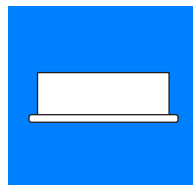

Without connection to keyboard housing **3.7**  
**0**

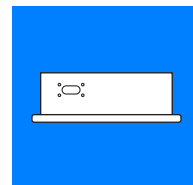

Connection to frame connector either rigid or adjustable **3.7**  
**1**

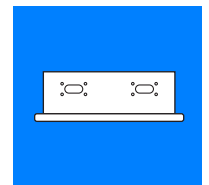

Connection with enclosure duct connector **3.7**  
**2**

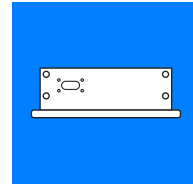

Connection with enclosure bar connector **3.7**  
**3**

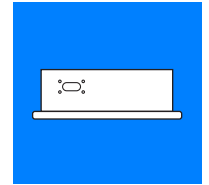

Connection with hinged frame connector **3.7**  
**4**

To fit keyboard housing depth:

Connection of operating housing to keyboard housing: (Selection 4.4, page 225)

Cable tube: (Selection 4.5, page 226)

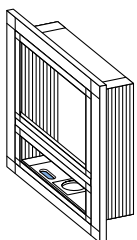

3.1	3.2	3.3	3.3	3.4	3.5	3.6	3.7	3.8	3.9
							3.7		

### 3.8 Rear panels

<sup>1)</sup> On the longest side (right/bottom), cam with double-bit insert, may be exchanged for lock inserts 41 mm, type C, see page 956, plastic handles and T handles, type C, see page 954/955.

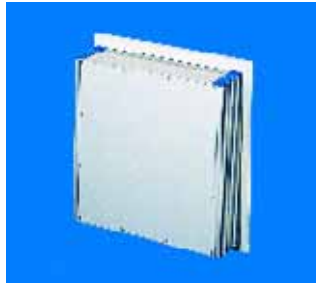

**Screw-fastened**  
**Material:**  
Aluminium,  
natural-anodised

3.8  
1



**Hinged<sup>1)</sup>**  
for rapid service access  
**Material:**  
Aluminium, natural-anodised

3.8  
2

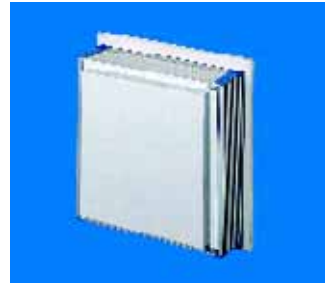

**Depth plus 45 mm**  
hinged,  
screw-fastening  
**Material:**  
Sheet steel, RAL 7035

3.8  
3

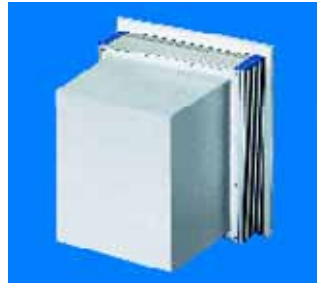

**Depth plus 245 mm,**  
square<sup>2)</sup>, screw-fastened  
**Material:**  
Sheet steel, RAL 7035  
<sup>2)</sup> For 482.6 mm (19")/7 U  
concave

3.8  
4



**Hinged<sup>1)</sup>**  
for heavy installed  
equipment  
**Material:**  
Aluminium, natural-anodised

3.8  
5

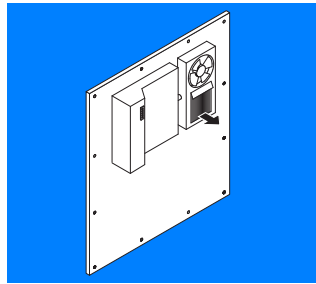

**Screw-fastened with  
built-in VIP SK small  
cooling unit, condenser  
assembly at the top left**  
Recommended for operating  
housing design (see 3.1 from an  
installation depth of 185 mm)  
**Material:**  
Aluminium, natural-anodised  
**Detailed drawing,**  
see page 641.

3.8  
6

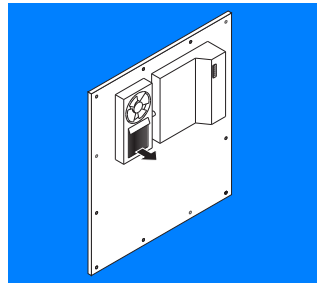

**Screw-fastened with  
built-in VIP SK small  
cooling unit, condenser  
assembly at the top right**  
Recommended for operating  
housing design (see 3.1 from an  
installation depth of 185 mm)  
**Material:**  
Aluminium, natural-anodised  
**Detailed drawing,**  
see page 641.

3.8  
7



**Rear cooling panel,  
modular<sup>3)</sup>**  
Increases the dissipation of  
heat loss from the enclosure  
by approx. 10 %.  
**Material:**  
Extruded aluminium section,  
natural-anodised  
**Detailed drawing  
and arrangement of sections,**  
see page 1206.

3.8  
8

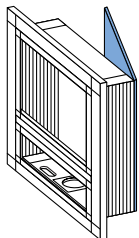

3.1	3.2	3.3	3.4	3.5	3.6	3.7	3.8	3.9
							3.8	



<sup>3)</sup> When installing the pull-out keyboard CP 6002.1X0 (see page 1137) in the VIP 6000, design variant 3.1, no. 1 the cooling fins and screw channels protruding 11 mm into the enclosure may be milled off in this area. Please state the installation position when ordering.

# Command Panel VIP 6000

## Selection: Operating housings

### 3.9 Integration of accessories

In addition to the design code, you should also indicate the position or enclose a sketch.

<sup>1)</sup> Interface inserts may be found on page 1151, these may also be fitted by specifying the Model No. and position.



Without accessories

3.9  
0

**Interface flap, single, with plastic flap<sup>1)</sup>**  
from installation depth 155 mm

3.9  
1

**Interface flap, double, with plastic flap<sup>1)</sup>**  
only possible in the front panel, spacer and built-in trim panel or rear panel.

3.9  
2

**Interface flap, single, with metal flap<sup>1)</sup>**  
from installation depth 155 mm

3.9  
3

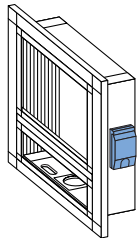

3.1	3.2	3.3	3.4	3.5	3.6	3.7	3.8	3.9

**Interface flap, double, with metal flap<sup>1)</sup>**  
only possible in the front panel, spacer and built-in trim panel or rear panel.

3.9  
4

**USB/RJ 45 extension**  
For order information, refer to page 1150.

3.9  
5

**Mounting preparations for signal pillars**  
Mounting component, see page 1129. Signal pillars, modular, see page 1126.

3.9  
6

### 4.1 Keyboard housing

Without fins.

For the internal or surface mounting of keyboards.

All keyboard housings are custom-produced to your dimensions. When selecting the wide front frame, the width of the keyboard housing depends on the operating housing.

**Material:**  
Extruded aluminium section

**Detailed drawing,**  
see page 1211 – 1213.

**! Also required:**

Mounting kit for installing front panels, operating panels and keyboards in operating and keyboard housings, see page 1121.

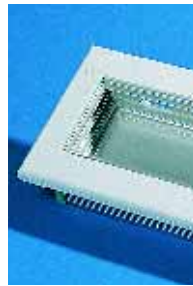

Installation depth 105 mm for built-in keyboards **4.1**  
**1**

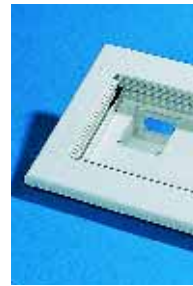
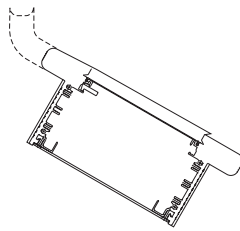

Installation depth 44 mm for built-in keyboards **4.1**  
**2**

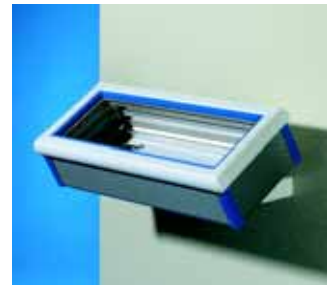
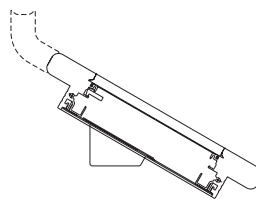

**Example of the versatility of the keyboard housing: Mounting on doors**  
With all keyboard housings, the rear panel may be supplied prepared for external mounting on flat surfaces on request.

**! Also required:**

Enclosure duct connector CP 6006.000, see page 1119. For mounting and cable entry.



Support for keyboards with cable entry grommet **4.1**  
**3**

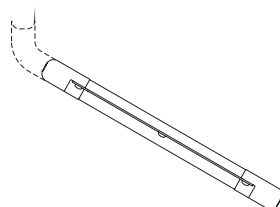

Support for keyboards with cable tube, flexible **4.1**  
**4**

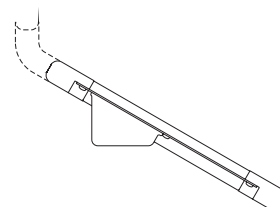

Support for keyboards with cable entry grommet<sup>1)</sup> **4.1**  
**5**

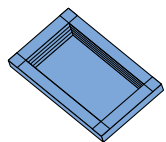
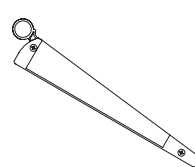

<b>4.1</b>	<b>4.2</b>	<b>4.3</b>	<b>4.4</b>	<b>4.5</b>
------------	------------	------------	------------	------------

<sup>1)</sup> Only in conjunction with hinged frame connector, see 4.4 design code number **5**.

# Command Panel VIP 6000

## Selection: Keyboard housing

### 4.2 Trim types<sup>1)</sup>

Detailed drawing, see page 1210.

<sup>1)</sup> Selection not possible with support for keyboards. In such cases, please enter an **X**.



**Cover trim**  
To cover the front panel assembly screws. For front panel thickness up to 3.5 mm.

4.2  
1



**End trim**  
Attractively finishes off the space between the front panel and the frame section. For all front panel thicknesses.

4.2  
2



**Spacer trim**  
For installed equipment flush with the frame section. For front panel thickness approx. 3.5 mm.

4.2  
3

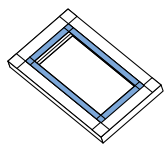

4.1	4.2	4.3	4.4	4.5

Command Panel VIP 6000

1.4

B

### 4.3 Trim colours<sup>1)</sup>

**Note:**  
Enclosure corner protectors are supplied in the chosen colour. Other colours available on request with larger orders.

<sup>1)</sup> Selection not possible with support for keyboards. In such cases, please enter an **X**.



**Turquoise**  
(similar to RAL 5018)

4.3  
1

**Bright blue**  
(similar to RAL 5005)

4.3  
2

**Bright red**  
(similar to RAL 3001)

4.3  
3

**Pebble grey**  
(similar to RAL 7030)

4.3  
5

**Graphite grey**  
(similar to RAL 7024)

4.3  
6

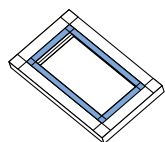

4.1	4.2	4.3	4.4	4.5

### 4.4 Keyboard housing connector

Supplied loose with the keyboard housing for connecting operating housings and keyboard housings.

To fit keyboard housing depth:

Tilt angle:

Cable tube:



Frame connector (rigid)

4.4  
1

105
44
Support for keyboards
120°, rigid
See 4.5

To fit operating and keyboard housings with the same width.

**Material:**  
Die-cast zinc, RAL 7035



Frame connector (adjustable)

4.4  
2

105
44
Support for keyboards
75 – 120°, adjustable in 7.5° increments
See 4.5

To fit operating and keyboard housings with the same width.

**Material:**  
Die-cast zinc, RAL 7035



Enclosure duct connector

4.4  
3

105
–
–
120°, rigid
Integral

To fit operating housings with keyboard housings 105 mm deep, also available in different widths.

**Material:**  
Aluminium, RAL 7035



Enclosure bar connector

4.4  
4

To fit keyboard housing depth:

Tilt angle:

Cable tube:

–
44
120°, rigid
See 4.5

To fit operating housings with keyboard housings 44 mm deep, also available in different widths.

**Material:**  
Sheet steel, RAL 7035



Hinged frame connector

4.4  
5

To fit keyboard housing depth:

Tilt angle:

Cable tube:

105
44
75 – 120°, infinitely adjustable
See 4.5

To fit operating housings with keyboard housings 105, 44 mm deep and support for keyboards, also available in different widths.

**Material:**  
Aluminium, RAL 7035

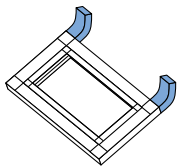

4.1	4.2	4.3	4.4	4.5
			4.4	



# Command Panel VIP 6000

## Selection: Keyboard housing

### 4.5 Cable tube

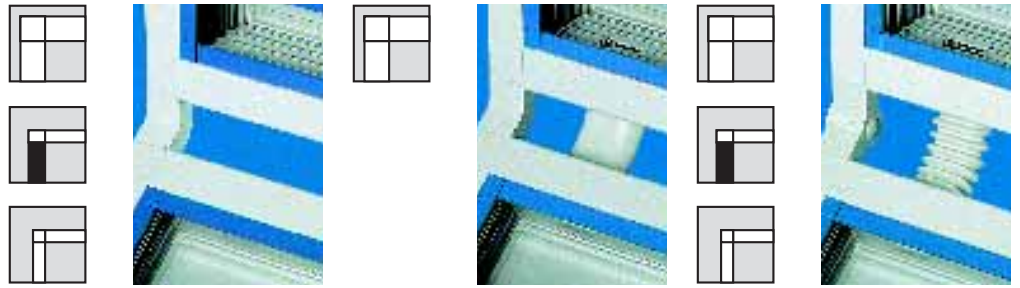

Without cable tube

4.5  
0

Cable tube, rigid

4.5  
1

Cable tube, flexible

4.5  
2

Suitable for cable routing when using the rigid frame connector (for wide frames) and keyboard housings with a depth of 105 mm.

**Material:**  
Aluminium, RAL 7035

**Note:**  
Not possible with:  
3.1 Operating housing, design code numbers 3 and 7.  
4.4 Keyboard housing connector, design code 2.

Suitable for cable entry when using the frame connector, adjustable, hinged frame connector or enclosure bar connector. For mounting on keyboard housings with an installation depth of 105 mm, 44 mm or support for keyboards.

**Material:**  
Plastic, RAL 7035

**Note:**  
Not possible with:  
4.1 Keyboard housing, design code numbers 3 and 5.

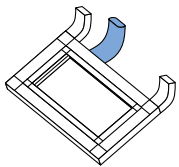

4.1	4.2	4.3	4.4	4.5
				1

### Example

The picture opposite shows the solution we have chosen, together with its corresponding design code number. The following key explains how the code number in our example is made up.

#### We need the following information in order to deal with your enquiry/order:

- Model No. front frame: CP 6392.X09<sup>1)</sup>
- The dimensions and number of panels/front panels to be installed in the operating/keyboard housing
- Design code number for the operating/keyboard housing

Order form, available on the Internet.

### Operating housing

Model No.: CP 6392.009

Design code number:

3.1	3.2	3.3	3.4	3.5	3.6	3.7	3.8	3.9
1	1	1	1	2	2	1	2	1

- 3.1 1** Operating housing, installation depth 155 mm
- 3.2 1** With one cross member
- 3.3 1** No fins
- 3.4 1** Cover trim
- 3.5 2** Trim colour: Bright blue
- 3.6 2** Support arm connection CP-L, Ø 130 mm, bottom
- 3.7 1** Connection with frame connector, rigid
- 3.8 2** Rear panel, hinged with double bit lock
- 3.9 1** Fitted interface flap

### Keyboard housing

Model No.: CP 6351.009

Design code number:

4.1	4.2	4.3	4.4	4.5
1	1	2	1	1

- 4.1 1** Keyboard housing, installation depth 105 mm
- 4.2 1** Cover trim
- 4.3 2** Trim colour: Bright blue
- 4.4 1** Frame connector, rigid
- 4.5 1** Cable tube, rigid

<sup>1)</sup> Replace X with the number after selecting the front frame.

**Note:**  
If the design code number does not cover your requirements, please enter an X and enclose a written explanation.

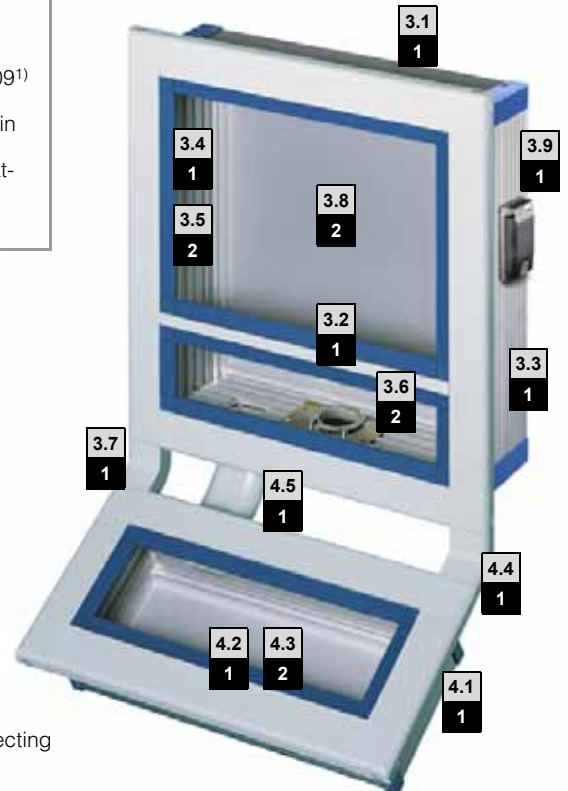

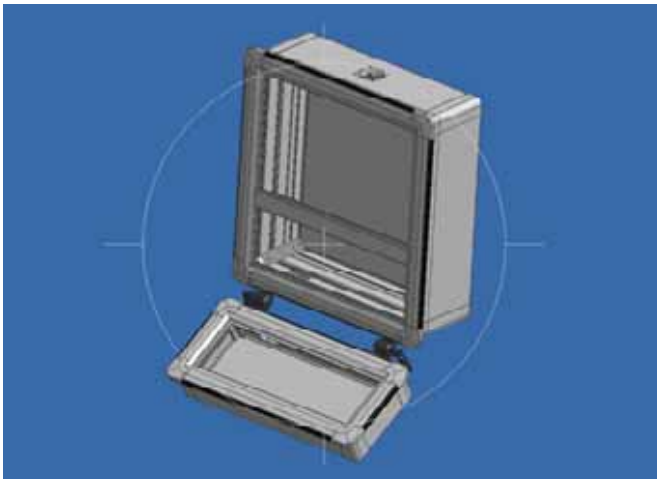

### Comfort Panel and Optipanel Configurator

Individual, perfectly coordinated panel solutions can be configured using these online tools. The configurator guides you automatically through the catalogue of questions in the individual selection masks. There is also an integrated intelligent consistency check that ensures that your selected configuration is complete, feasible and error-free.

When you have completed your configuration you can display a visual presentation and 3D CAD model of your separate command panel solutions in the format of your choice, which can be imported into your machines and plant design. You can also call up an online quote from Rittal.

#### Benefits at a glance:

- Design your panel solution at a click of the mouse
- Check the installation of pre-defined command panels
- Integrated consistency checks to exclude configuration errors
- The possibility of using a standard size is automatically checked
- Detailed description of the specified panel
- Sent to you:
  - A visual presentation of the enclosure
  - 3D CAD data for interlinking the machines and plant design to display a virtual prototype on the screen
  - A quote for the selected command panel solution.



Further information can be found at:  
[www.rittal.com/configurator](http://www.rittal.com/configurator)

## Guides to the dissipatable heat loss with aluminium operating housings

for front panel dimensions  $W = 482.6 \text{ mm (19")}$  x  $H = 310.3 \text{ mm (7 U)}$

Operating housings	Model No. CP	Installation depth mm	Enclosure <sup>1)</sup> without fins	Enclosure <sup>1)</sup> with partial fins	Enclosure <sup>1)</sup> with fins all round	Page
Comfort Panel	6372.009	152	100 W	115 W	–	197
Optipanel	6382.009	150	80 W	–	–	206
VIP 6000	6392.X09	155	105 W	120 W	135 W	216

<sup>1)</sup> With additional use of the rear cooling panel, the dissipatable heat loss is increased by around 10 %.

Tests were carried out under the following conditions:

- Single enclosure, free-standing (location)
- Difference between internal and external temperature  $\Delta t = 20 \text{ K}$

#### Note:

Other dimensions may be checked using the Rittal Therm software (see page 1155).

## Other climate control options

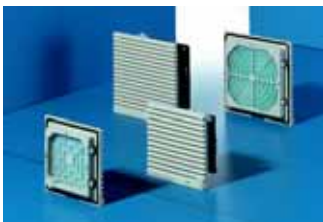

**Fan-and-filter unit,**  
see page 690.



**Air/water heat exchangers,**  
see page 676.



**Small cooling unit,**  
see page 641.

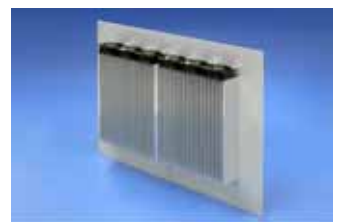

**DCP Panel Cooling,**  
(on request) see page 735.