

**STUART**

**Aquastor ECO SAE 130, SAE 150, SAE 215, SAE 255**

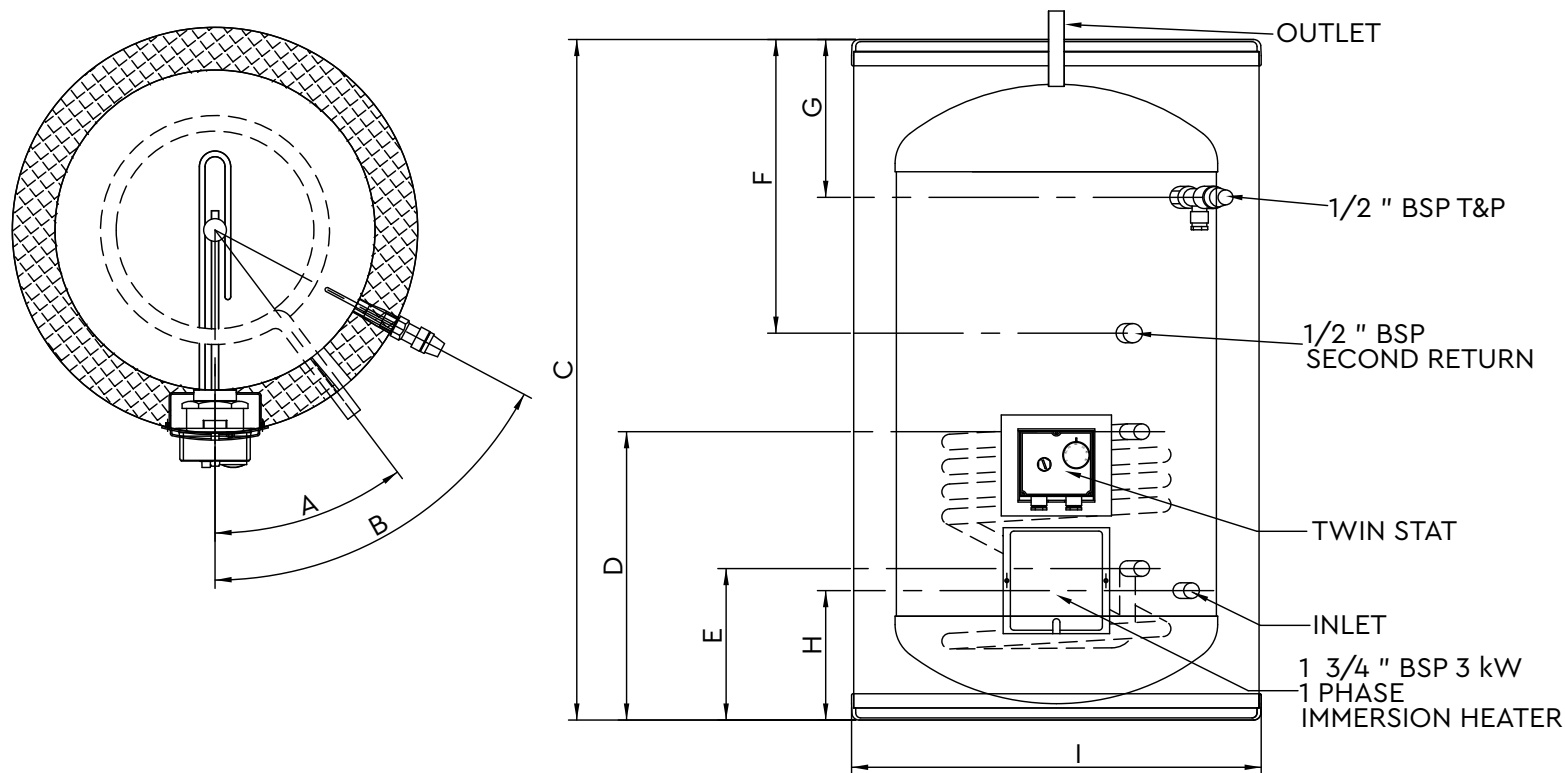

Model	Dim. 'A' (deg)	Dim. 'B' (deg)	Dim. 'C'	Dim. 'D'	Dim. 'E'	Dim. 'F'	Dim. 'G'	Dim. 'H'	Dim. 'I' (dia)
SAE 130	37	62	957 mm	406.0 mm	213 mm	413 mm	222 mm	182 mm	576 mm
SAE 150	37	62	1085 mm	405.5 mm	213 mm	413 mm	222 mm	182 mm	576 mm
SAE 215	37	62	1484 mm	475.5 mm	213 mm	474 mm	222 mm	182 mm	576 mm
SAE 255	37	62	1752 mm	475.5 mm	213 mm	542 mm	222 mm	182 mm	576 mm

Dimensions in millimetres

Stuart Turner Ltd own the copyright within this document. The document may be printed for personal use only. The document must not be altered, reproduced or utilised in any way without written permission from Stuart Turner Ltd, Henley-on-Thames, Oxfordshire, RG9 2AD, England. Stuart Turner Limited reserves the right to amend specifications without notice.

Stuart Turner Ltd, Henley-on-Thames, Oxfordshire RG9 2AD Tel: +44 (0) 1491 572655 Fax: +44 (0) 1491 573704

TechAssist Helpline +44 (0) 800 969 80

www.stuart-turner.co.uk

Issue: 2019/1