

STUART

Aquastor Sigma SAS 305, SAS 400, SAS 500

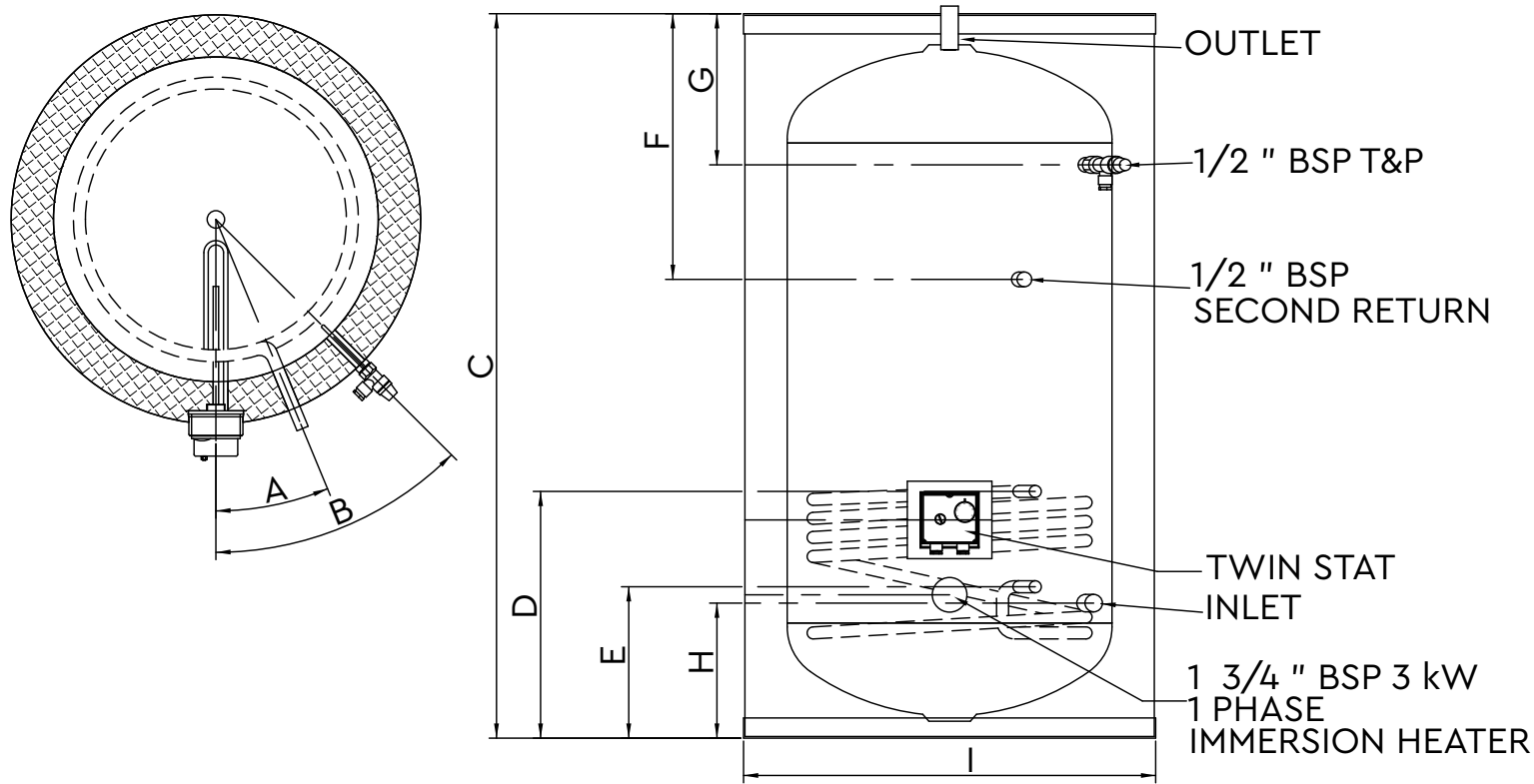

Dimensions in millimetres

Model	Dim. 'A' (deg)	Dim. 'B' (deg)	Dim. 'C'	Dim. 'D'	Dim. 'E'	Dim. 'F'	Dim. 'G'	Dim. 'H'	Dim. 'I' (dia)
SAS 305	37	62	2028 mm	476 mm	213 mm	610 mm	222 mm	182 mm	576 mm
SAS 400	22.5	45	1640 mm	523 mm	278 mm	487 mm	277 mm	248 mm	755 mm
SAS 500	22.5	45	2000 mm	523 mm	278 mm	558 mm	277 mm	248 mm	755 mm

Stuart Turner Ltd own the copyright within this document. The document may be printed for personal use only. The document must not be altered, reproduced or utilised in any way without written permission from Stuart Turner Ltd, Henley-on-Thames, Oxfordshire, RG9 2AD, England. Stuart Turner Limited reserves the right to amend specifications without notice.

Stuart Turner Ltd, Henley-on-Thames, Oxfordshire RG9 2AD Tel: +44 (0) 1491 572655 Fax: +44 (0) 1491 573704

TechAssist Helpline +44 (0) 800 969 80

www.stuart-turner.co.uk

Issue: 2919/2