

INDUSTRIAL MANIPULATORS by SCAGLIA INDEVA

SCAGLIA SpA offer equipments which represent the **latest in weight management technology**: user friendly lifters which are ergonomically designed to allow the operator to move, rotate, lift or lower any load up to 320 Kg. effortlessly, as if it were **weightless**. Work gets easier and more efficient, productivity is increased while the risk of repetitive stress injuries and damage to materials is reduced.

They are used in the premises of many **well known brands** in food and beverage industry: Sanpellegrino, Britvic Soft Drinks, Coca Cola, Cameo, Kelloggs, Kraft Foods, Nestlé, Saiwa, Acque e Terme di Uliveto etc...

They comply with all European **safety** regulations: the system lifts a load only if it's gripped correctly and safely and cannot be released whilst being moved, or until it's placed onto a steady support.



They are needed for:

- Loading cardboard blanks onto **case packers** magazines (see next page).
- Loading shrink wrap film reels onto **shrinkwrappers** (see next page)
- Loading label reels onto **labellers**.
- Loading stretch film reels onto **stretchwrappers**.
- Handling **paper reels** (right).
- Picking up and moving **five cases** of bottles at a time (left above).
- Picking up **four 5 gallons bottles** vertically and positioning them horizontally (left center).
- Handling two 5 lts bottles at a time (right) by means of **Liftronic EASY**, an electronic manipulator, compact, economic and unique in the market for its many advantages.
- Picking up **and precisely positioning** several **wine bottles** at a time (below).
- Handling **barrels of beer** several times a day (bottom right).



In the pictures above: the paper reel (H 1000 x dia 600 mm - 180 kg.) is picked up from the pallet with axis in vertical position; then it's rotated through 90° and released on the floor with axis in horizontal position. The tool grips the reel in its core, thus preventing the material wound on the reel from being touched and damaged.



SCAGLIA is present worldwide with its branches and sales network: call or e-mail for a free evaluation

Scaglia Indeva s p a - 24012 Brembilla BG Italy T. (+39) 0345 59411 Fax (+39) 0345 59500
E-mail: info@it.indevagroup.com <http://www.indevagroup.com>

INDEVA
INTELLIGENT DEVICES FOR HANDLING

INDUSTRIAL MANIPULATORS by SCAGLIA INDEVA

APPLICATION SAMPLES in food & beverage industry

HANDLING CARDBOARD BLANKS

Bundle size: 1120 x 625 x 300 mm - weight: 30 kg.

HANDLING CYCLE: Scaglia's manipulator picks up the cardboard bundle from the pallet at a height of 965 mm from the floor. The bundle is picked up in vertical position (see sketch) by means of two jaws with powered clamp/release functions. The load weight is automatically balanced so that the operator can move the load effortlessly. Then the bundle is rotated through 90° and placed onto the cardboard magazine of the case packer in horizontal position.

SCAGLIA'S MANIPULATOR easily suits any working area thanks to its 3 m long articulated "orbit arm" capable of 300° rotation. It's compact, which ensures great visibility during handling operations. It is mounted on top a 2.8 m high column that can be bolted to the floor or secured to a moveable pallet base. This system is the result of a thirty-year experience and guarantees efficiency and full safety.

ADVANTAGES OF USING SCAGLIA'S SYSTEM:

Loading a 100 blank bundle on the cardboard magazine of a high speed case packer takes only 15 seconds with no risk of repetitive strain injuries for the operator.

PRODUCTIVITY AND SAFETY HAVE HIGHLY INCREASED



Cardboard magazine

WRAP AROUND CASE PACKER

Positioning cardboard blank bundles horizontally after 90° rotation

Picking up vertical cardboard blank bundles

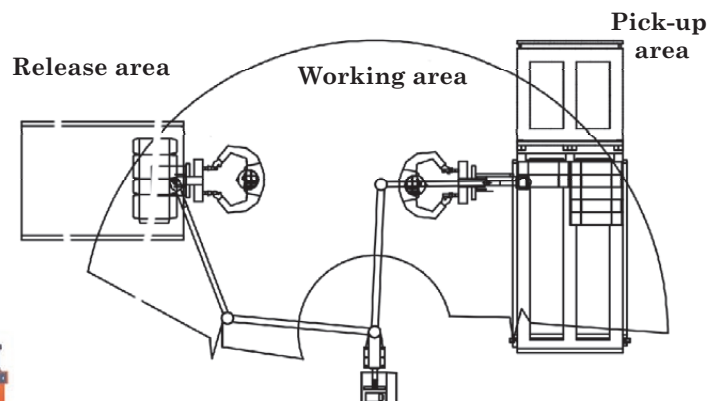
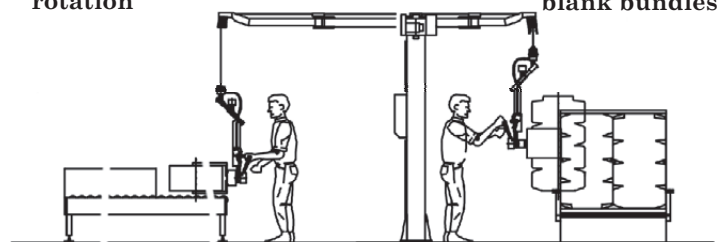

SHRINKWRAPPER



The shrink film reel is loaded here after rotation through 90°

Shrink film reel in horizontal position. Scaglia's manipulator loads it gently, precisely and quickly onto the shrinkwrapper

Pick-up area

Shrink wrap film reel

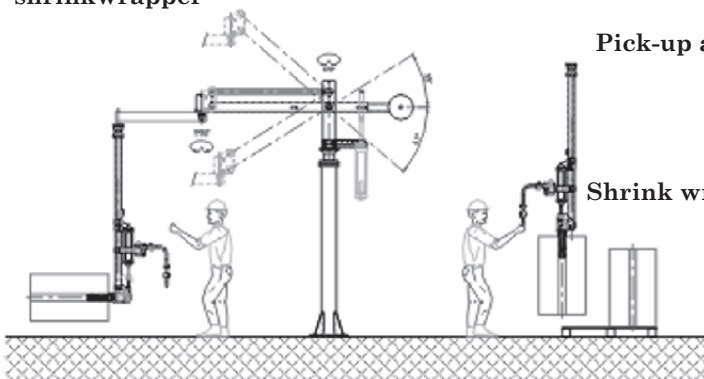

HANDLING SHRINK FILM REELS

Reel size: this pneumatic manipulator "PN ERGO" by SCAGLIA can handle a wide range of reel sizes, with length up to 1200 mm, outside diameter up to over 600 mm and weight up to 200 kg.

HANDLING CYCLE: Scaglia's manipulator "PN ERGO" picks up the reel in vertical position, by means of an expanding chuck gripping the reel in its core. The load is automatically balanced, so that the operator can move the load effortlessly. The reel is rotated through 90° and loaded onto the shrinkwrapper.